

## Seismic and Hurricane Ties

Attach and secures trusses and rafters to the building structure.

ClarkDietrich seismic and hurricane ties are designed to provide wind and seismic resistance for trusses and rafters. Quick and efficient, these versatile connectors can also be used for general tie-down purposes, strong back attachments and as all-purpose ties where one member crosses another. The HC2 and HC2A seismic and hurricane ties are formed from a flat plate into an A-shaped section. The plate has a right-angle bend along its longitudinal axis to permit straddling a top plate. The HC2.5 and HC3 are twisted strap ties that are used to attach a rafter to the side of the top plate.

### ALTERNATIVE PRODUCTS

EasyClip™ T-Series™ Tall Anchor Clip

EasyClip E-Series™ Support Clip

### MATERIAL SPECIFICATIONS

**Gauge:** 18 gauge (43mil)

**Design Thickness:** 0.0451 inches

**Coating:** G90

**Yield Strength:** 50ksi

**ASTM:** A653/A653M

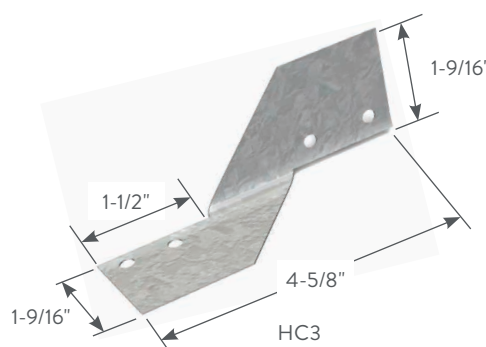
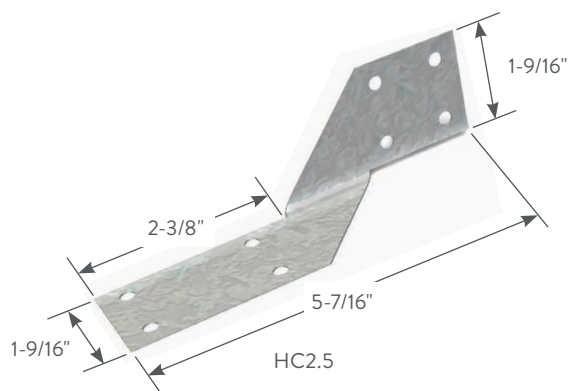
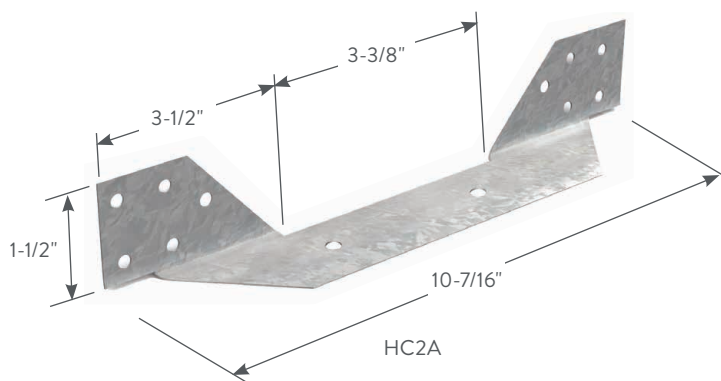
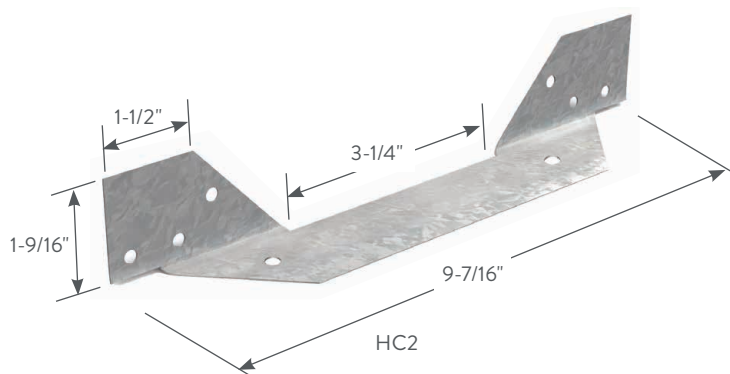

### ClarkDietrich Seismic and Hurricane Ties

Product code	Thickness		Size (in)	Packaging Pcs./Carton
	Mils (Gauge)	Design thickness (in)		
HC2	43mil (18ga)	0.0451	1-9/16 x 9-7/16 x 1-9/16	100
HC2A	43mil (18ga)	0.0451	1-1/2 x 10-7/16 x 1-1/2	100
HC2.5	43mil (18ga)	0.0451	1-9/16 x 5-7/16 x 1-9/16	100
HC3	43mil (18ga)	0.0451	1-9/16 x 4-5/8 x 1-9/16	100

**HC2 OR HC2A INSTALLATION**

Place the tie so one end fits flush against the roof framing member and the other fits flush against the web of the wall stud. Attach the tie to the side of the rafter at the top and to the sides of the stud immediately below the top plate at the bottom. Fill all prepunched holes with a minimum of #10 self-drilling screws.

**HC2.5 OR HC3 INSTALLATION**

Place the tie so the top fits securely against the roof framing member and the bottom fits securely against the top plate and flange of the wall stud. Attach the tie to the rafter at the top and to the sides of the top plate and stud immediately below. Fill all prepunched holes with a minimum #10 self-drilling screws.

Reference section R 603.8.3.2 of the International Residential Code (IRC) or the engineer of records specification.

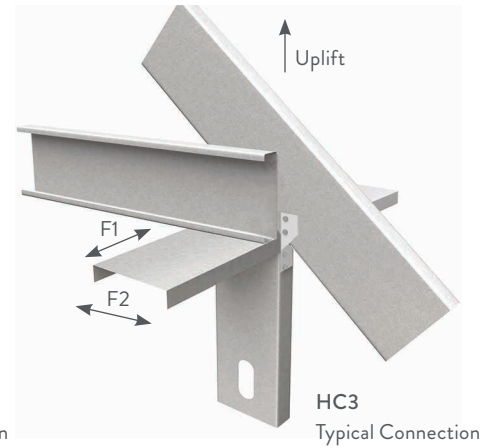
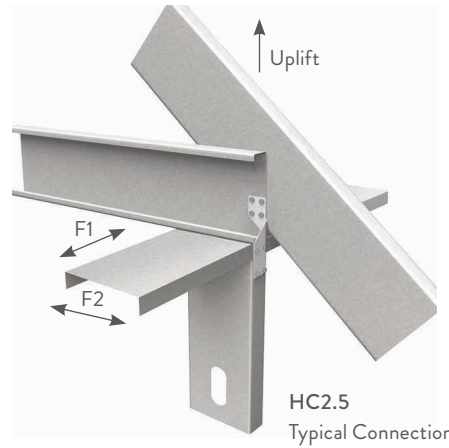
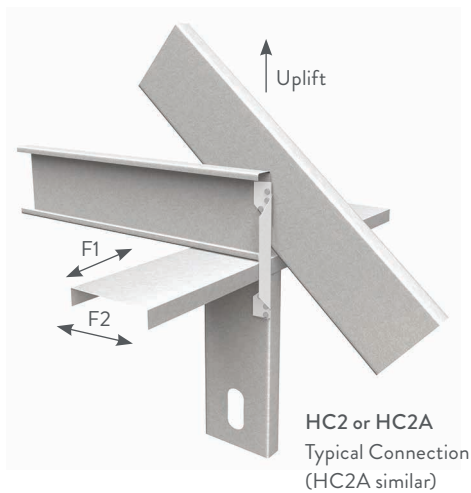

Typical Construction Details  
Visit our CAD Library at [clarkdietrich.com](http://clarkdietrich.com)  
to view or download construction details in  
.dwg, .dxf, and .pdf formats.

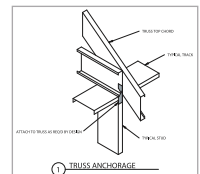

**ClarkDietrich Seismic and Hurricane Ties**

Product code	Fasteners			Stud thickness mil (ga, ksi)	Max. Allowable Loads		
	To rafters / truss	To top track	To stud		Uplift	Lateral	
						F1	F2
HC2	3 - #10	—	3 - #10	33 (20ga 33ksi)	405	—	—
				43 (18ga 33ksi)	445	—	—
				54 (16ga 50ksi)	465	—	—
HC2A	3 - #10	1 - #10	3 - #10	33 (20ga 33ksi)	405	90	120
				43 (18ga 33ksi)	445	110	170
				54 (16ga 50ksi)	465	110	225
HC2.5	4 - #10	—	4 - #10	33 (20ga 33ksi)	410	90	120
				43 (18ga 33ksi)	475	140	170
				54 (16ga 50ksi)	475	140	225
HC3	2 - #10	2 - #10*	—	33 (20ga 33ksi)	340	80	80
				43 (18ga 33ksi)	465	110	140
				54 (16ga 50ksi)	475	110	195

**Notes:**

- 1 Loads have been increased for wind or earthquake loading.
- \* Fasteners to top track must also penetrate.