

Extended Uni-Clip™ w/Anchor Holes

The Extended Uni-Clip™ connects exterior studs to the primary structure of the building, while resisting horizontal and vertical loads.

ClarkDietrich's UXRC6-HD 68mils (14ga) rigid framing clip is used to attach exterior wall studs to the structure of the building. This clip is ideal for all medium and large standoff conditions and designed to resist horizontal and vertical loads. (1) 5/8" hole in the short leg of the clip allows for a 1/2" concrete anchor to be attached to the slab. (2) 3/8" holes allow 1/4" anchors.

MATERIAL SPECIFICATIONS

- Gauge:** 14 gauge (68mils)
- Design Thickness:** 0.0713 inches
- Coating:** G90
- Yield Strength:** 50 ksi
- ASTM:** A653/A653M

INSTALLATION

Attach the Extended Uni-Clip rigid clips to cold-formed steel framing members using #12 minimum self-drilling screws driven through the clip holes into the steel framing. Follow the required fastener placement patterns to achieve the allowable load. Attachment to the structure concrete slab can be made with (1) 1/2" or (2) 1/4" bolt anchors. Anchor connection design and edge distance requirements must be approved by a design professional before installation.

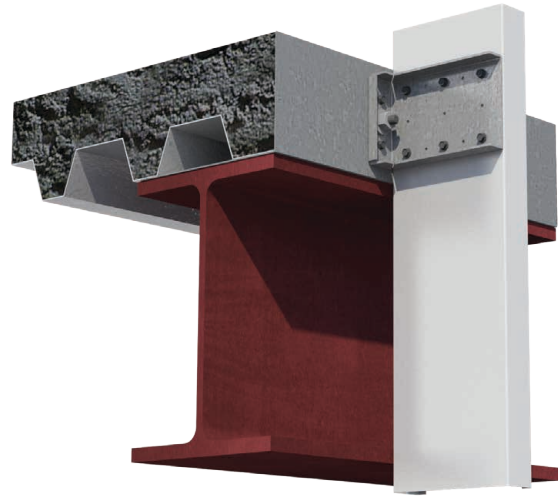

PRODUCT DIMENSIONS

6" Extended Uni-Clip: 1-1/2" x 4-1/4" x 6"

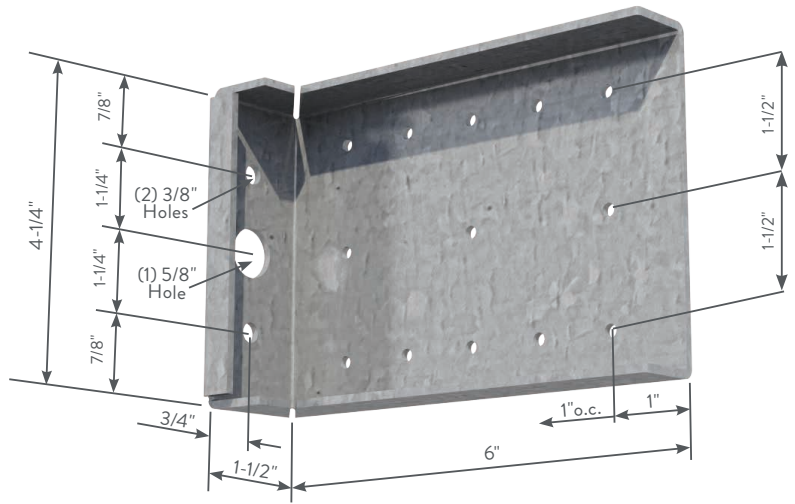

UXRC6-HD

Extended Uni-Clip™ (UXRC6-HD)

Product code	Thickness		Size (in)	Packaging Pcs./ Bucket
	Mils (Gauge)	Design thickness (in)		
UXRC6-HD	68mil (14ga)	0.0713	1-1/2 x 4-1/4 x 6	25

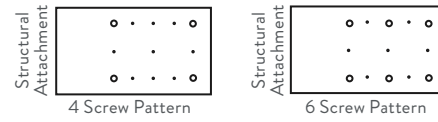
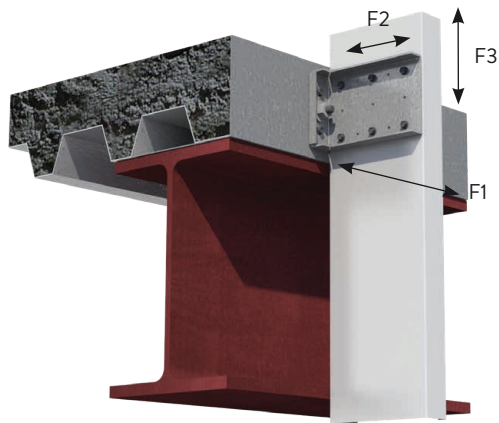

UXRC6-HD Screw Pattern

Extended Uni-Clip™ (UXRC6-HD) Allowable Loads

ANCHOR DESIGN BY OTHERS

Product name	Stud thickness gauge (mils)	Stud fy (ksi)	Mechanically Anchored to Structure	ASD Allowable Loads (lb.)					
				F1 Load		F2 Load		F3 Load	
				w/4 #12-14	w/6 #12-14	w/4 #12-14	w/6 #12-14	w/4 #12-14	w/6 #12-14
UXRC6-HD 14ga (68mil)	33mil (20ga)	33	Anchors to be designed by others	165	165	754	1131	361	471
	43mil (18ga)	33		232	232	1122	1428*	537	701
	54mil (16ga)	50		405	405	1428*	1428*	1091	1423
	68mil (14ga)	50		527	527	1568*	1568*	1488	1600
	97mil (12ga)	50		809	809	1667*	1667*	1488	1908

* Capacities governed by 1/8" service load criteria.

Extended Uni-Clip™ (UXRC6-HD) Allowable Loads

CONSIDERING ANCHOR CAPACITIES

Product name	Stud thickness gauge (mils)	Stud fy (ksi)	Mechanically Anchored to Structure	ASD Allowable Loads (lb.)					
				F1 Load		F2 Load		F3 Load	
				w/4 #12-14	w/6 #12-14	w/4 #12-14	w/6 #12-14	w/4 #12-14	w/6 #12-14
UXRC6-HD 14ga (68mil)	33mil (20ga)	33	(1) 1/2" Hilti KWIK Bolt TZ ^a (3000 psi uncracked concrete)	165	165	754	1131	351	471
	43mil (18ga)	33		232	232	1122	1199	502	682
	54mil (16ga)	50		405	405	1199	1199	983	1280
	68mil (14ga)	50		527	527	1339	1339	1336	1413
	97mil (12ga)	50		809	809	1339	1339	1488	1628
	33mil (20ga)	33	(2) 1/4" Hilti KWIK HUS-EZ ^b (3000 psi uncracked concrete)	141	141	754	1131	361	471
	43mil (18ga)	33		207	207	1122	1403	537	701
	54mil (16ga)	50		397	397	1403	1403	1091	1423
	68mil (14ga)	50		484	484	1403	1403	1488	1600
	97mil (12ga)	50		803	803	1403	1403	1488	1838

Notes:

- Table-1 contains the allowable load capacity of the clip and the screw connection to the CFS stud. When the mechanical anchors between the clip and the support structure are designed by others, pull-over shall be included in the evaluation of F2 loads, and bearing shall be included in the evaluation of F3 loads.
- Table-2 considers capacities listed in Notes 3 and 4 (below) when the specified connectors to the structure are used.
- When using 1/2" Hilti KWIK Bolt TZ anchor (nominal embedment depth of 2-3/8") into 3000psi concrete, anchor capacity shall be limited to:
 - a Tension capacity/anchor: 1509-lbs (uncracked concrete) and 1069-lbs (cracked concrete)
 - b Shear capacity/anchor: 1628-lbs (uncracked concrete) and 1153-lbs (cracked concrete)
- When using 1/4" Hilti KWIK HUS-EZ anchor (nominal embedment depth of 2-1/2") into 3000psi concrete, anchor capacity shall be limited to:
 - a Tension capacity/anchor: 752-lbs (uncracked concrete) and 374-lbs (cracked concrete)
 - b Shear capacity/anchor: 919-lbs (uncracked concrete) and 651-lbs (cracked concrete)
- Connector capacities listed in Note 4 utilize load adjustment/reduction (anchor spacing) factors of 0.72 for tension and 0.60 for shear as per 2016 Hilti Anchor Fastening Technical Guide (see Hilti Table 6 and 7 under section 3.3.6.3).
- Where anchors are loaded simultaneously in tension and shear, interaction must be considered following anchor manufacturer guidelines.
- Capacities listed in the table/notes did not consider load adjustment for edge distance of anchors. For no reduction in the listed capacities, the following requirements needed to be met for the concrete surface where the clip attaches:
 - a When using 1/2" Hilti KWIK Bolt TZ anchor embedded 2-3/8" deep into 3000psi concrete, minimum edge distance shall be:
 - i) 5-1/2" for uncracked concrete;
 - ii) 4-1/8" for cracked concrete
 - b When using 1/4" Hilti KWIK HUS-EZ anchors embedded 2-1/2" deep into 3000psi concrete, minimum edge distance shall be:
 - i) 4-1/2" for uncracked concrete
 - ii) 4-1/2" for cracked concrete
- Other anchors may be used to achieve the full clip capacity but must be designed separately.
- Allowable loads have not been increased for wind, seismic, or other factors.
- Hilti is a registered trademark of Hilti Aktiengesellschaft Corporation.
- It is the responsibility of the designer to properly detail connections on the contract drawings.