

## EasyClip™ A-Series™ End Clip

For knee-wall connections or to reinforce jamb stud connections at the primary frame.

ClarkDietrich EasyClip™ A-Series™ end clips are most commonly used to reinforce connections in knee-wall applications or to reinforce jamb stud connections to the primary frame. These clips are unpunched as the specific application will determine the appropriate number and placement of fasteners.

### ALTERNATIVE PRODUCTS

EasyClip™ D-Series™ Anchor Clip  
EasyClip T-Series™ Tall Anchor Clip  
SwiftClip™ LA-Series™ Support Clip

### PRODUCT DIMENSIONS

3" x 3" x 3"

3" x 3" x 6"

### MATERIAL SPECIFICATIONS

**Gauge:** 16 gauge (54mil)

**Design Thickness:** 0.0566 inches

**Gauge:** 14 gauge (68mil)

**Design Thickness:** 0.0713 inches

**Gauge:** 12 gauge (97mil)

**Design Thickness:** 0.1017 inches

**Coating:** G90

**Yield Strength:** 50ksi

**ASTM:** A653/A653M

### INSTALLATION

EasyClip A-Series end clips are attached to cold-formed steel (CFS) framing members using #10 minimum self-drilling screws. Clips can also be welded to the CFS framing. Connections to the building frame can be made with powder-actuated fasteners, drill-in concrete anchors or welding. When using the tabular values for a welded clip, provide a full weld to the structure, top to bottom, along the outside of the clip. A 3/4" minimum weld to the outside edge of the 3" leg is also recommended to control warping or to hold the clip in place before final welding.

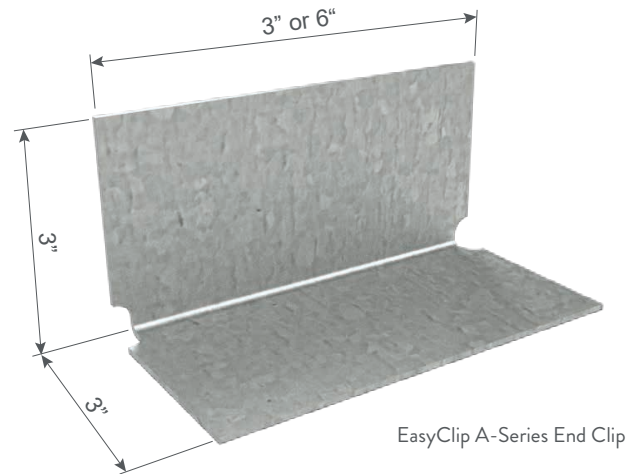

EasyClip A-Series End Clip

### EasyClip™ A-Series™ End Clips

Product code	Thickness		Size (in)	Packaging Pcs./Bucket
	Mils (Gauge)	Design thickness (in)		
A543	54mil (16ga)	0.0566	3 x 3 x 3	100
A546	54mil (16ga)	0.0566	3 x 3 x 6	100
A683	68mil (14ga)	0.0713	3 x 3 x 3	100
A686	68mil (14ga)	0.0713	3 x 3 x 6	100
A973	97mil (12ga)	0.1017	3 x 3 x 3	100
A976	97mil (12ga)	0.1017	3 x 3 x 6	50

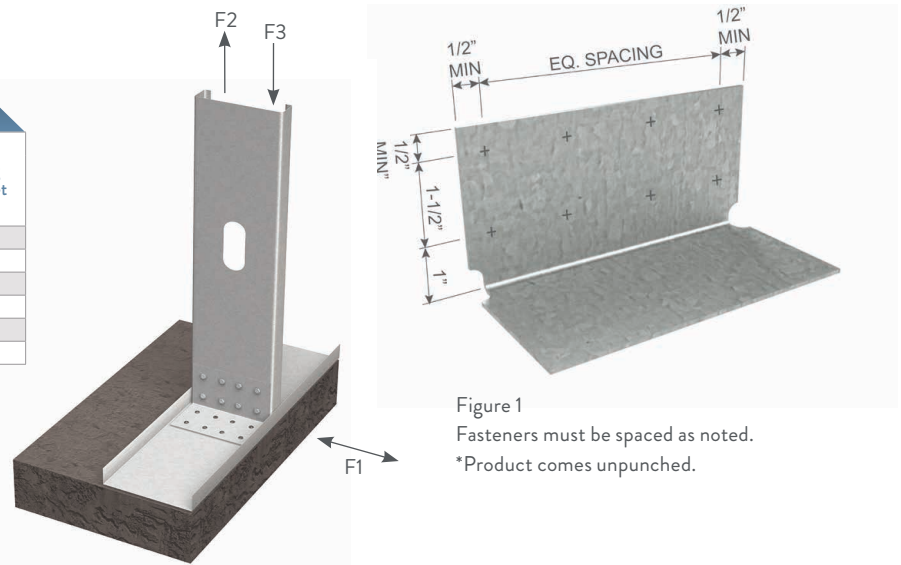

Figure 1

Fasteners must be spaced as noted.  
\*Product comes unpunched.

## EasyClip™ A-Series™ End Clips Allowable Clip Capacities (lbs)

USING #10-16  
SELF-DRILLING SCREWS

Clip	No. of screws to steel framing (1)	Stud Thickness and Yield Strength								
		20ga (33mil) 33ksi			18ga (43mil) 33ksi			16ga (54mil) 50ksi		
		F1	F2	F3	F1	F2	F3	F1	F2	F3
A543	4	354 (354)	120 (708)	708	525 (375)	120 (1050)	1050	775 (375)	120 (1365)	1381
	6	531 (375)	120 (1062)	1062	775 (375)	120 (1365)	1381	775 (375)	120 (1365)	1381
A546	6	531 (531)	241 (1062)	1062	788 (788)	241 (1576)	1576	1400 (1355)	241 (2730)	2800
	8	708 (708)	241 (1416)	1416	1050 (1050)	241 (2101)	2101	1867 (1355)	241 (2730)	3452
	10	885 (885)	241 (1770)	1770	1313 (1313)	241 (2626)	2626	2333 (1355)	241 (2730)	3452
	12	1062 (1062)	241 (2124)	2124	1576 (1355)	241 (2730)	3151	2634 (1355)	241 (2730)	3452
A683	4	354 (354)	190 (708)	708	525 (472)	190 (1050)	1050	933 (472)	190 (1718)	1867
	6	531 (472)	190 (1062)	1062	788 (472)	190 (1576)	1576	1149 (472)	190 (1718)	2353
A686	6	531 (531)	381 (1062)	1062	788 (788)	381 (1576)	1576	1400 (1400)	381 (2800)	2800
	8	708 (708)	381 (1416)	1416	1050 (1050)	381 (2101)	2101	1867 (1705)	381 (3436)	3733
	10	885 (885)	381 (1770)	1770	1313 (1313)	381 (2626)	2626	2333 (1705)	381 (3436)	4667
	12	1062 (1062)	381 (2124)	2124	1576 (1576)	381 (3151)	3151	2800 (1705)	381 (3436)	5600
A973	4	354 (354)	388 (708)	708	525 (525)	388 (1050)	1050	933 (673)	388 (1867)	1867
	6	531 (531)	388 (1062)	1062	788 (673)	388 (1576)	1576	1400 (673)	388 (2451)	2800
A976	6	531 (531)	775 (1062)	1062	788 (788)	775 (1576)	1576	1400 (1400)	775 (2800)	2800
	8	708 (708)	775 (1416)	1416	1050 (1050)	775 (2101)	2101	1867 (1867)	775 (3733)	3733
	10	885 (885)	775 (1770)	1770	1313 (1313)	775 (2626)	2626	2333 (2333)	775 (4667)	4667
	12	1062 (1062)	775 (2124)	2124	1576 (1576)	775 (3151)	3151	2800 (2432)	775 (4903)	5600

**Notes:**

**Screw Capacity Notes:**

- The tabulated value indicates the number of screws in a single clip leg attached to the cold-formed steel (CFS) framing.
- Screws shall be attached in a symmetric manner starting at the top and bottom moving to the center, see Figure 1 opposite page.
- The allowable values for F1 are based only on the shear capacity of the clip leg attached to the CFS framing. The capacity of the attachment to other materials and structures must be checked separately.
- The allowable values for F2 assume mechanical fasteners are attached to the structure and are located no more than 1" away from the angle bend. Mechanical fasteners to other materials and structures must be checked separately.
- This table is intended for use by qualified engineers only. It is the responsibility of the engineer to verify that the tabulated values apply to a specific connection application.
- When clips have combinations of F1, F2 and F3, use a linear interaction for combinations of F1 and F3, and a squared interaction for combinations of F1 and F2.

7 Allowable loads have not been increased 33% for wind or seismic.

8 For connections made to 14 gauge (68mil) and 12 gauge (97mil), use the tabulated values for 16 gauge (54mil), 50ksi.

9 It is the responsibility of the design professional to detail the drawings for proper clip attachment.

10 Contact ClarkDietrich at 888-437-3244 for technical assistance.

**Weld Capacity Notes:**

- F1 and F2 values in parentheses are maximum shear and tension capacities when the clips are welded to the base structure (min. 3/16" – 36ksi steel).
- Listed weld capacities are computed assuming an E70XX welding rod or wire.
- The clips are to be welded to the structure along the back corner along the complete length of the clip. When secondary welds are used to hold the clip in place, they are not used in capacity calculations. 3/4" min. secondary weld as required to control warping or to hold clip in place before final welding.

**TYPICAL CONSTRUCTION DETAILS**

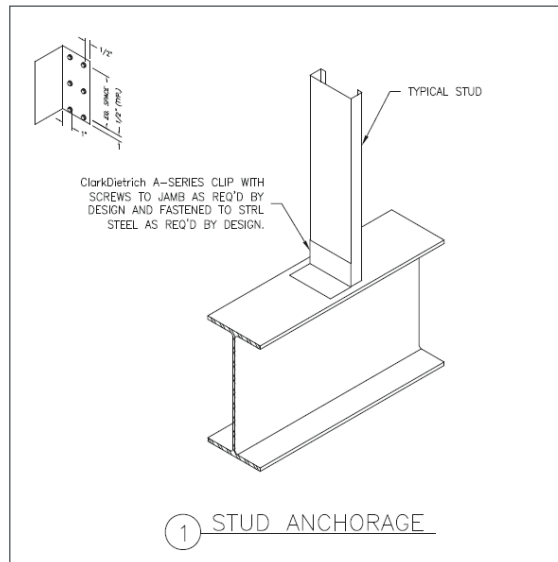
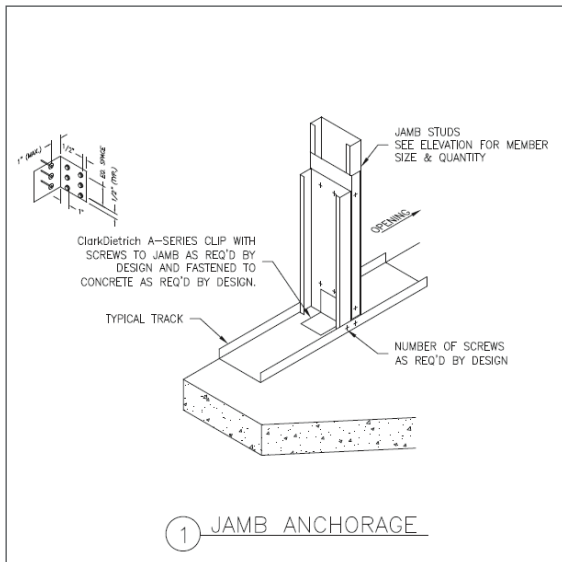

Visit our CAD Library at [clarkdietrich.com](http://clarkdietrich.com) to view or download construction details in .dwg, .dxf, and .pdf formats.