

## Drift Rail and Clip

## Curtain Wall/Bypass with Drift and Vertical Deflection

### Vertical and lateral building movement

ClarkDietrich Drift Rail (DR) or Drift Headed Rail (DHR) with Drift Rail Clip (DRC), is a uniquely designed two-piece system that is used to attach curtain-wall studs to the building structure and allows for vertical and lateral movement or to be rigidly attached. The system utilizes a C-Shaped Drift Rail and distinctively designed Drift Rail Clips that rotate into position for easy installation. The multifaceted Drift Rail Clips use Proprietary Deflection Screws for attachment to the wall studs and allows for 3" vertical deflection (1-1/2" up and down) and is also designed with 1/8" holes to rigidly attach wall studs.

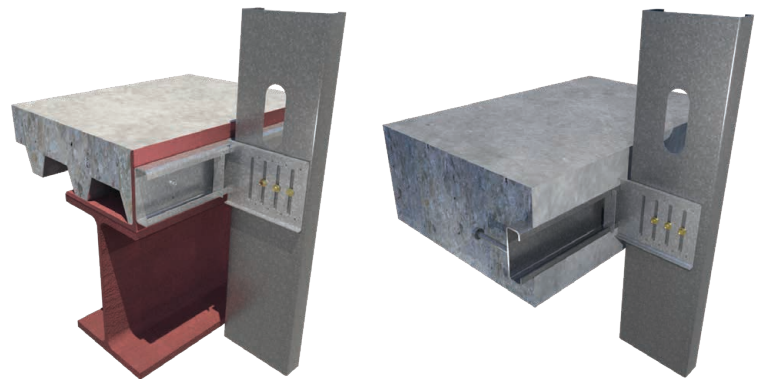

Drift Rail (DR) Installation

Drift Headed Rail (DHR) Installation

### ALTERNATIVE PRODUCTS

Drift FastClip™ Slide Clip

### MATERIAL SPECIFICATIONS

**Yield Strength:** 50ksi

**Coating:** G90

**ASTM:** A653 / A1003

### DRIFT RAIL (S)

**Gauge:** 12ga (97mil)

**Design Thickness:** 0.1017"

**Min. Thickness:** 0.0966"

### HEADED STUD MATERIAL SPECIFICATIONS

**Yield Strength:** Grade 1010 through 1020, 51ksi

**ASTM:** A29/A108

**AWS:** D1.1

**Dimensions:** 3/8" dia. x 3" long with 3/4" head dia.

### DRIFT RAIL CLIP

**Gauge:** 12ga (97mil)

**Design Thickness:** 0.1017"

**Min. Thickness:** 0.0966"

**Gauge:** 14ga (68mil)

**Design Thickness:** 0.0713"

**Min. Thickness:** 0.0677"



DRC3

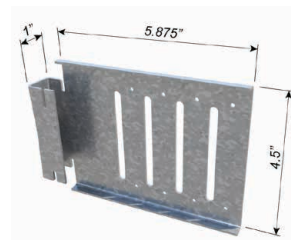

DRC6

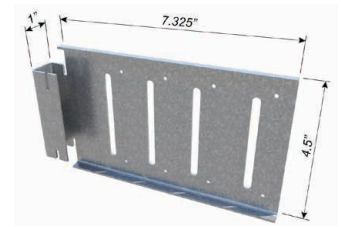

DRC8

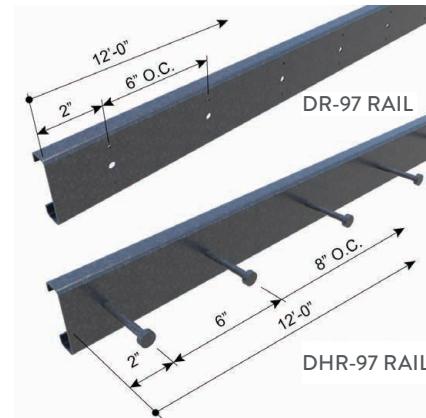

### DRC - 12ga Clip / 12ga Rail

Product code	Thickness	Size (in)	No. of slots per Clip	No. of holes per clip	Drift Clips per box	Prop. Screws per box
	Mils (Gauge)					
DRC3-97	97mil (12ga)	3.3875"	2	4	25	55 or 80
DRC6-97		5.875"	4	8	25	55 or 80
DRC8-97		7.325"	4	8	25	55 or 80

### DRC - 14ga Clip / 12ga Rail

Product code	Thickness	Size (in)	No. of slots per Clip	No. of holes per clip	Drift Clips per box	Prop. Screws per box
	Mils (Gauge)					
DRC3-68	68mil (14ga)	3.3875"	2	4	25	55 or 80
DRC6-68		5.875"	4	8	25	55 or 80
DRC8-68		7.325"	4	8	25	55 or 80



Proprietary Deflection Screw

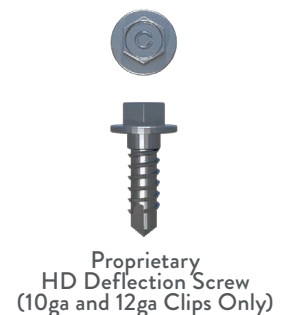

Proprietary HD Deflection Screw (10ga and 12ga Clips Only)

Note: 12' Drift Rail(s) are individually packaged.

**INSTALLATION**

Install the Drift Rail to minimum 3/16-in thick **steel** support structure using:

- Welds
- PAF fasteners
- Self-drilling screws

Install the Drift Rail to **concrete** support structure using:

- Expansion anchors
- Screw anchors
- Cast In Place / Embedded (Drift Headed Rail only)

Pilot holes are provided along the length of the Drift Rail web at a spacing of 6-in on-center. (DR rail only)

Design load capacities for commonly used fasteners are tabulated in the product Design Guide and include:

- Hilti X-U Universal Knurled Shank Fasteners
- #12-24 HWH Fasteners
- Hilti 1/4" KWIK HUS-EZ anchor

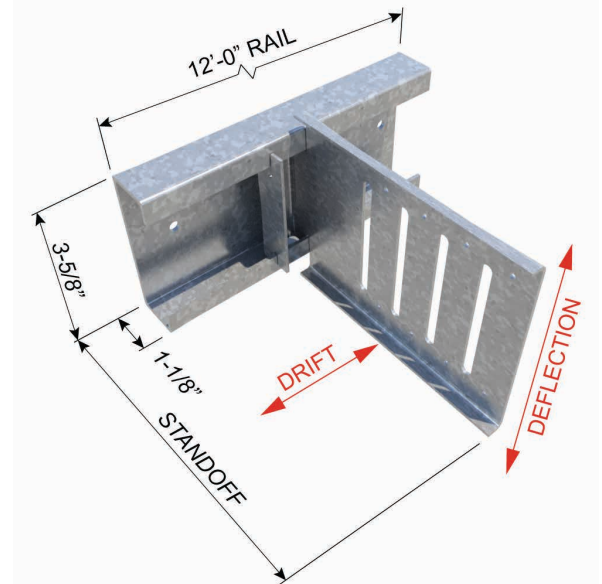

With the Drift Rail or Drift Headed Rail installed on the structure, the Drift Clips can be positioned as required:

- The framing stud web must contact the flat face of the long leg of the Drift Clip.
- Note that one of the four slots in the channel portion of the Drift Clip is longer than the others.
- Tilt the Drift Clip and position it so that the longer slot initially engages one leg of the Drift Rail.
- Rotate the Drift Clip to the vertical position, engaging all four slots with the Drift Rail legs.

**Connection between the Drift Clip and Framing Studs:**

- For bypass connections, Proprietary Deflection Screws are placed through each slotted hole of the long leg, of the Drift Clip to the web of the stud. The required number and location of the slotted holes used to secure the stud is determined by the required design load capacity.
- For rigid connections, self-drilling screws are placed through the pilot holes around the perimeter of the long leg of the Drift Clip to the web of the stud.

To restrict clip lateral movement (Drift) along the Drift Rail, install one of two types of stops:

- Drift Locking Angle (DRLA) is an L-shaped clip
  - The long leg is inserted into the channel of the Drift Rail Clip,
  - The short leg is secured to the flange of the Drift Rail with a #10 self-drilling screw
- Drift Locking Clip (DRLC) is a C-shaped clip
  - The DRLC sits within the channel of the Drift Clip, and straddles the flanges of the Drift Rail.
  - The two outside legs of the DRLC are secured to each flange of the Drift Rail with a #10 self-drilling screw.

