

## ClarkDietrich Moment Clip

Moment connection for knee walls and shear walls to the structure foundation.

ClarkDietrich moment clips are high-performance, cost effective solutions for knee wall-to-foundation connections and shear wall-to-foundation connections. These multi-application clips feature a 1/4" thick A36 steel stiffening plate that provides superior design values for maximum performance. The moment clips are designed to resist horizontal, torsional and vertical (uplift) loads. These clips are prepunched with a series of attachment holes for steel framing connections and a 1/2" anchor bolt hole for foundation connections.

### PRODUCT DIMENSIONS

- 2" x 4" x 3-1/2"
- 2" x 4" x 5-1/2"
- 2" x 4" x 7-1/2"

- 1/4" A36 steel stiffening plate
- 1-3/4" x 3-3/8"
- 1-3/4" x 5-3/8"
- 1-3/4" x 7-3/8"

### MATERIAL SPECIFICATIONS

- Gauge:** 14 gauge (68mil)
- Design Thickness:** 0.0713 inches
  
- Gauge:** 12 gauge (97mil)
- Design Thickness:** 0.1017 inches
  
- Gauge:** 10 gauge (118mil)
- Design Thickness:** 0.1242 inches
  
- Coating:** G90
- Yield Strength:** 50ksi
- ASTM:** A36, A653, A1003

### INSTALLATION

Secure the Moment Clip to the steel framing member by using #12 screws in the prepunched holes. Number of screws and screw pattern is based on load required to achieve listed capacities.

Place 1/4" steel stiffening plate on top of short leg of Moment Clip so anchor holes are aligned.

Secure 1/4" steel stiffening plate and Moment Clip to foundation using 1/2" x 2" long Hilti Kwik-Bolt 3 or alternate anchorage calculated to resist the tension load for your specific application.

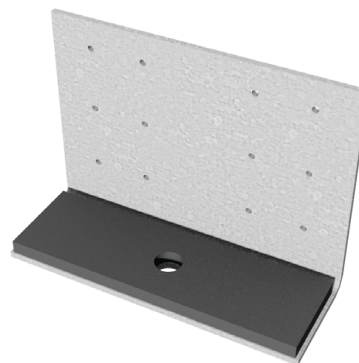
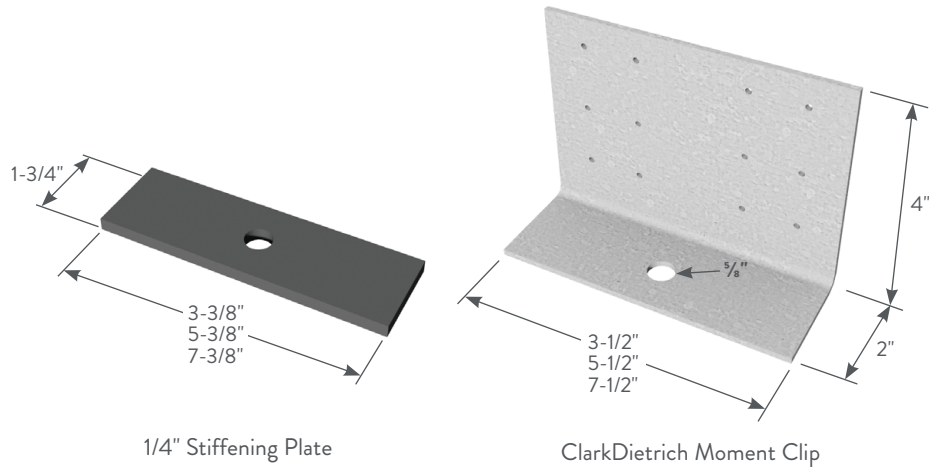

### ClarkDietrich Moment Clips (MC Series)

Product code	Thickness		Size (in)	Packaging Pcs./Bucket
	Mils (Gauge)	Design thickness (in)		
MC683P	68mil (14ga)	0.0713	2" x 4" x 3-1/2"	25
MC685P	68mil (14ga)	0.0713	2" x 4" x 5-1/2"	25
MC687P	68mil (14ga)	0.0713	2" x 4" x 7-1/2"	25
MC973P	97mil (12ga)	0.1017	2" x 4" x 3-1/2"	25
MC975P	97mil (12ga)	0.1017	2" x 4" x 5-1/2"	25
MC977P	97mil (12ga)	0.1017	2" x 4" x 7-1/2"	25
MC103P	68mil (14ga)	0.1242	2" x 4" x 3-1/2"	25
MC105P	97mil (12ga)	0.1242	2" x 4" x 5-1/2"	25
MC107P	118mil (10ga)	0.1242	2" x 4" x 7-1/2"	25

### ClarkDietrich Moment Clips Allowable Loads

Product code	Stud member thickness Mils (Gauge)	Stud Fy (ksi)	F1 (Shear), (lbs)			F2 (Tension), (lbs)			M (Moment), (in-lbs)			Rotational stiffness for wind deflection (in-lbs/radian)
			Number of #12 screws to stud						1/2" dia. anchor to structure			
			4	6	12	4	6	12	4	6	12	
<b>MC683P</b> 2" x 4" x 3-1/2" 68mil (14ga)	33mil (20ga)	33	372	508	840	754	1131	2261 <sup>2</sup>	1401	1784	2462 <sup>3</sup>	133,000
	43mil (18ga)	33	554	756	1250	1122	1683 <sup>2</sup>	2736 <sup>2</sup>	2084 <sup>3</sup>	2581 <sup>3</sup>	2581 <sup>3</sup>	
	54mil (16ga)	50	1126	1536	2086 <sup>1</sup>	2278 <sup>2</sup>	2736 <sup>2</sup>	2736 <sup>2</sup>	2743 <sup>3</sup>	2743 <sup>3</sup>	2743 <sup>3</sup>	
	68mil (14ga)	50	1535	2086 <sup>1</sup>	2086 <sup>1</sup>	2736 <sup>2</sup>	2736 <sup>2</sup>	2736 <sup>2</sup>	2756 <sup>3</sup>	2756 <sup>3</sup>	2756 <sup>3</sup>	
	97mil (12ga)	50	1535	2086 <sup>1</sup>	2086 <sup>1</sup>	2736 <sup>2</sup>	2736 <sup>2</sup>	2736 <sup>2</sup>	2756 <sup>3</sup>	2756 <sup>3</sup>	2756 <sup>3</sup>	
<b>MC973P</b> 2" x 4" x 3-1/2" 97mil (12ga)	33mil (20ga)	33	372	508	840	754	1131	2261 <sup>2</sup>	1401	1784 <sup>3</sup>	2560 <sup>3</sup>	140,100
	43mil (18ga)	33	554	756	1250	1122	1683 <sup>2</sup>	3365 <sup>2</sup>	2084 <sup>3</sup>	2655	2862 <sup>3</sup>	
	54mil (16ga)	50	1126	1536	2538 <sup>1</sup>	2278 <sup>2</sup>	3417 <sup>2</sup>	4065 <sup>2</sup>	2862 <sup>3</sup>	2862 <sup>3</sup>	2862 <sup>3</sup>	
	68mil (14ga)	50	1535	2094 <sup>1</sup>	2975 <sup>1</sup>	3107 <sup>2</sup>	4181 <sup>2</sup>	4181 <sup>2</sup>	2862 <sup>3</sup>	2862 <sup>3</sup>	2862 <sup>3</sup>	
	97mil (12ga)	50	1535	2094 <sup>1</sup>	2975 <sup>1</sup>	3107 <sup>2</sup>	4181 <sup>2</sup>	4181 <sup>2</sup>	2862 <sup>3</sup>	2862 <sup>3</sup>	2862 <sup>3</sup>	
<b>MC103P</b> 2" x 4" x 3-1/2" 118mil (10ga)	33mil (20ga)	33	372	508	840	754	1131	2261 <sup>2</sup>	1401	1784 <sup>3</sup>	2609 <sup>3</sup>	143,900
	43mil (18ga)	33	554	756	1250	1122	1683 <sup>2</sup>	3365 <sup>2</sup>	2084 <sup>3</sup>	2655	2945 <sup>3</sup>	
	54mil (16ga)	50	1126	1536	2538 <sup>1</sup>	2278 <sup>2</sup>	3417 <sup>2</sup>	3828 <sup>2</sup>	2945 <sup>3</sup>	2945 <sup>3</sup>	2945 <sup>3</sup>	
	68mil (14ga)	50	1535	2094 <sup>1</sup>	3462 <sup>1</sup>	3107 <sup>2</sup>	3828 <sup>2</sup>	3828 <sup>2</sup>	2945 <sup>3</sup>	2945 <sup>3</sup>	2945 <sup>3</sup>	
	97mil (12ga)	50	1535	2094 <sup>1</sup>	3462 <sup>1</sup>	3107 <sup>2</sup>	3828 <sup>2</sup>	3828 <sup>2</sup>	2945 <sup>3</sup>	2945 <sup>3</sup>	2945 <sup>3</sup>	
<b>MC685P</b> 2" x 4" x 5-1/2" 68mil (14ga)	33mil (20ga)	33	441	630	1029	754	1131	2261 <sup>2</sup>	1778	2417	3396 <sup>3</sup>	252,000
	43mil (18ga)	33	656	937	1531	1122	1683 <sup>2</sup>	2736 <sup>2</sup>	2646	3597 <sup>3</sup>	4993 <sup>3</sup>	
	54mil (16ga)	50	1333	1903 <sup>1</sup>	2086 <sup>1</sup>	2278 <sup>2</sup>	2736 <sup>2</sup>	2736 <sup>2</sup>	5307 <sup>3</sup>	5307 <sup>3</sup>	5307 <sup>3</sup>	
	68mil (14ga)	50	1818 <sup>1</sup>	2086 <sup>1</sup>	2086 <sup>1</sup>	2736 <sup>2</sup>	2736 <sup>2</sup>	2736 <sup>2</sup>	5363 <sup>3</sup>	5363 <sup>3</sup>	5363 <sup>3</sup>	
	97mil (12ga)	50	1818 <sup>1</sup>	2086 <sup>1</sup>	2086 <sup>1</sup>	2736 <sup>2</sup>	2736 <sup>2</sup>	2736 <sup>2</sup>	5363 <sup>3</sup>	5363 <sup>3</sup>	5363 <sup>3</sup>	
<b>MC975P</b> 2" x 4" x 5-1/2" 97mil (12ga)	33mil (20ga)	33	441	630	1029	754	1131	2261 <sup>2</sup>	1778	2417	3396 <sup>3</sup>	274,400
	43mil (18ga)	33	656	937	1531	1122	1683 <sup>2</sup>	3365 <sup>2</sup>	2646	3597 <sup>3</sup>	5025 <sup>3</sup>	
	54mil (16ga)	50	1333	1903 <sup>1</sup>	2975 <sup>1</sup>	2278 <sup>2</sup>	3417 <sup>2</sup>	4181 <sup>2</sup>	5373 <sup>3</sup>	5980 <sup>3</sup>	5980 <sup>3</sup>	
	68mil (14ga)	50	1818 <sup>1</sup>	2595 <sup>1</sup>	2975 <sup>1</sup>	3107 <sup>2</sup>	4181 <sup>2</sup>	4181 <sup>2</sup>	5980 <sup>3</sup>	5980 <sup>3</sup>	5980 <sup>3</sup>	
	97mil (12ga)	50	1818 <sup>1</sup>	2595 <sup>1</sup>	2975 <sup>1</sup>	3107 <sup>2</sup>	4181 <sup>2</sup>	4181 <sup>2</sup>	5980 <sup>3</sup>	5980 <sup>3</sup>	5980 <sup>3</sup>	
<b>MC105P</b> 2" x 4" x 5-1/2" 118mil (10ga)	33mil (20ga)	33	441	630	1029	754	1131	2261 <sup>2</sup>	1778	2417	3396 <sup>3</sup>	288,700
	43mil (18ga)	33	656	937	1531	1122	1683 <sup>2</sup>	3365 <sup>2</sup>	2646	3597 <sup>3</sup>	5053 <sup>3</sup>	
	54mil (16ga)	50	1333	1903 <sup>1</sup>	3109 <sup>1</sup>	2278 <sup>2</sup>	3417 <sup>2</sup>	4236 <sup>2</sup>	5373 <sup>3</sup>	6133 <sup>3</sup>	6133 <sup>3</sup>	
	68mil (14ga)	50	1818 <sup>1</sup>	2595 <sup>1</sup>	3633 <sup>1</sup>	3107 <sup>2</sup>	4236 <sup>2</sup>	4236 <sup>2</sup>	6133 <sup>3</sup>	6133 <sup>3</sup>	6133 <sup>3</sup>	
	97mil (12ga)	50	1818 <sup>1</sup>	2595 <sup>1</sup>	3633 <sup>1</sup>	3107 <sup>2</sup>	4236 <sup>2</sup>	4236 <sup>2</sup>	6133 <sup>3</sup>	6133 <sup>3</sup>	6133 <sup>3</sup>	
<b>MC687P</b> 2" x 4" x 7-1/2" 68mil (14ga)	43mil (18ga)	33	791	1164	1928 <sup>1</sup>	1122	1683 <sup>2</sup>	2736 <sup>2</sup>	3646	5199 <sup>3</sup>	6903 <sup>3</sup>	387,600
	54mil (16ga)	50	1606	2086 <sup>1</sup>	2086 <sup>1</sup>	2278 <sup>2</sup>	2736 <sup>2</sup>	2736 <sup>2</sup>	7403 <sup>3</sup>	7656 <sup>3</sup>	7656 <sup>3</sup>	
	68mil (14ga)	50	2086 <sup>1</sup>	2086 <sup>1</sup>	2086 <sup>1</sup>	2736 <sup>2</sup>	2736 <sup>2</sup>	2736 <sup>2</sup>	8186 <sup>3</sup>	8186 <sup>3</sup>	8186 <sup>3</sup>	
	97mil (12ga)	50	2086 <sup>1</sup>	2086 <sup>1</sup>	2086 <sup>1</sup>	2736 <sup>2</sup>	2736 <sup>2</sup>	2736 <sup>2</sup>	8186 <sup>3</sup>	8186 <sup>3</sup>	8186 <sup>3</sup>	
	43mil (18ga)	33	791	1164	1928 <sup>1</sup>	1122	1683 <sup>2</sup>	3365 <sup>2</sup>	3646	5199 <sup>3</sup>	6903 <sup>3</sup>	
<b>MC977P</b> 2" x 4" x 7-1/2" 97mil (12ga)	54mil (16ga)	50	1606	2363 <sup>1</sup>	2975 <sup>1</sup>	2278 <sup>2</sup>	3417 <sup>2</sup>	3875 <sup>2</sup>	7403 <sup>3</sup>	8979 <sup>3</sup>	8979 <sup>3</sup>	449,000
	68mil (14ga)	50	2190 <sup>1</sup>	2975 <sup>1</sup>	2975 <sup>1</sup>	3107 <sup>2</sup>	3875 <sup>2</sup>	3875 <sup>2</sup>	8979 <sup>3</sup>	8979 <sup>3</sup>	8979 <sup>3</sup>	
	97mil (12ga)	50	2190 <sup>1</sup>	2975 <sup>1</sup>	2975 <sup>1</sup>	3107 <sup>2</sup>	3875 <sup>2</sup>	3875 <sup>2</sup>	8979 <sup>3</sup>	8979 <sup>3</sup>	8979 <sup>3</sup>	
	43mil (18ga)	33	791	1164	1928 <sup>1</sup>	1122	1683 <sup>2</sup>	3365 <sup>2</sup>	3646	5199	6903 <sup>3</sup>	
	54mil (16ga)	50	1606	2363 <sup>1</sup>	3633 <sup>1</sup>	2278 <sup>2</sup>	3417 <sup>2</sup>	3835 <sup>2</sup>	7403 <sup>3</sup>	9180 <sup>3</sup>	9180 <sup>3</sup>	
<b>MC107P</b> 2" x 4" x 7-1/2" 118mil (10ga)	68mil (14ga)	50	2190 <sup>1</sup>	3223 <sup>1</sup>	3633 <sup>1</sup>	3107 <sup>2</sup>	4236 <sup>2</sup>	4236 <sup>2</sup>	9282 <sup>3</sup>	9282 <sup>3</sup>	9282 <sup>3</sup>	451,000
	97mil (12ga)	50	2190 <sup>1</sup>	3223 <sup>1</sup>	3633 <sup>1</sup>	3107 <sup>2</sup>	4236 <sup>2</sup>	4236 <sup>2</sup>	9282 <sup>3</sup>	9282 <sup>3</sup>	9282 <sup>3</sup>	

**Notes:**

- Cells marked with a "1" in shear column indicate that the shear capacity is limited to 1628 lbs when using 1/2" x 2" Hilti Kwik-Bolts into 3000psi concrete.
- Cells marked with a "2" in tension column indicate that the tension capacity is limited to 1509 lbs when using 1/2" x 2" Hilti Kwik-Bolts into 3000psi concrete.
- Cells marked with a "3" in the moment column indicate that the moment capacity is limited to 1761 in-lbs for 3-Series clips, 2767 in-lbs for 5-Series clips, and 3773 in-lbs for 7-Series clips when using 1/2" x 2" Hilti Kwik-Bolts into 3000psi concrete.
- Capacities listed in the table/notes assume that no load reductions are required for spacing or edge distance of Kwik-Bolts.
- Capacities listed in the table represent the capacity of the clip and the screws to the stud. Capacities listed in notes 1-3 are limits if the specified connector to the structure is used. Other 1/2" dia. anchors may be used to achieve the full clip capacity but must be designed separately.
- Moment capacities listed as Max. load/Factor of Safety. Loads must be limited by serviceability load taken as stiffness times the serviceability limit in radians.
- Stiffness is the max. allowable clip moment divided by the clip rotation measured at the max. allowable clip moment.
- No stud-to-track connection is required. Higher loads can be achieved when stud-to-track is connected.
- Use a linear interaction equation for connections involving any combination of F1, F2, and M.
- Allowable loads have not been increased for wind, seismic, or other factors.
- Torsional effects are considered on screw group for F1 & F2 (Shear & Tension) allowable loads.
- Hilti is a registered trademark of Hilti Aktiengesellschaft Corporation.
- It is the responsibility of the designer to properly detail connections on the contract drawings.

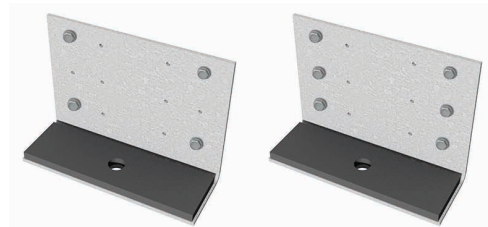

4 Screw Pattern

6 Screw Pattern

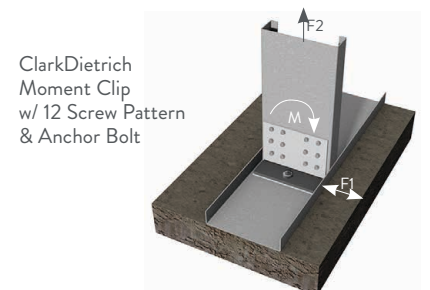

ClarkDietrich  
Moment Clip  
w/ 12 Screw Pattern  
& Anchor Bolt