

Field Skewable TradeReady® Rim Track Splice Plate (TDSP)

Ideal for splicing rim joist and is easily field skewable for off-angle rim joist connections.

The ClarkDietrich field skewable TradeReady® rim track splice plate provides an easy and efficient method for splicing TradeReady rim. This prepunched plate is also ideal for connecting and reinforcing the rim at bay or bow window details. The center of the plate allows for easy one-time field bending from 0° to 135°.

CAUTION: This plate can only be bent one time.

ALTERNATIVE PRODUCTS

Simpson® Strong-Tie® Skewable Angle

PRODUCT DIMENSIONS

4" x 6" (Can be bent to 2" x 2" x 6")

MATERIAL SPECIFICATIONS

Gauge: 18 gauge (43mil)

Design Thickness: 0.0451 inches

Yield Strength: 33ksi

Gauge: 16 gauge (54mil)

Design Thickness: 0.0566 inches

Yield Strength: 50ksi

Coating: G90

ASTM: A653/A653M

INSTALLATION

For splicing connections, align center slots in splice plate over the joint of the rim joists. Secure splice plate by filling all prepunched screw holes with #10 screws.

For off-angle connections, field bend (ONE TIME ONLY) to the required degree so the plate fits securely over the two adjoining members. Secure field skewable plate by filling all prepunched screw holes with #10 screws.

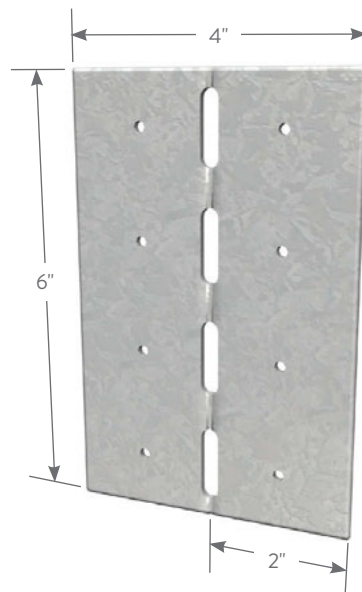

Field Skewable TradeReady Rim Track Splice Plate



FIELD SKEWABLE TradeReady® RIM TRACK SPLICE PLATES

Product code	Thickness			Size (in)	Packaging Pcs./Bucket
	Gauge	Mils	Design thickness (in)		
TDSP	18	43	0.0451	4 x 6	100
TDSP	16	54	0.0566	4 x 6	100

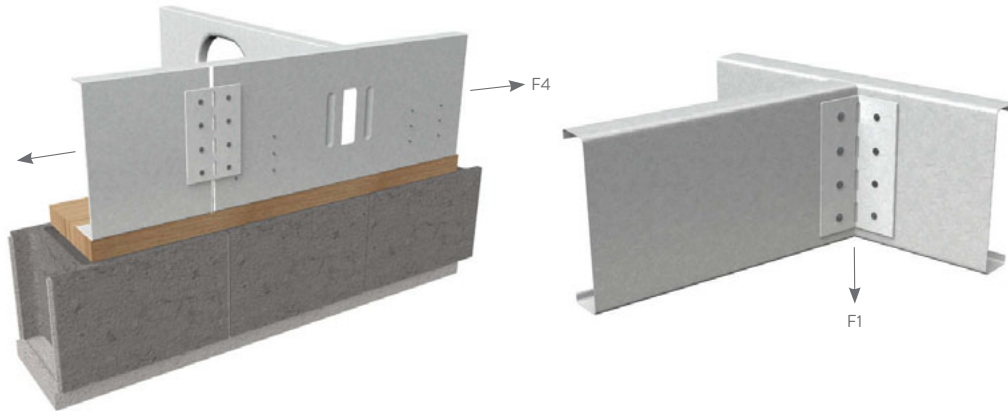

FIELD SKEWABLE TradeReady® RIM TRACK SPLICE PLATES

Allowable loads

Product code	TDSP gauge	Framing material gauge	Framing material yield (ksi)	Tension F4 (lbs)	Shear F1 (lbs)
TDSP	18	20	33	560	437
		18 or thicker	33	832	650
TDSP	16	20	33	560	437
		18	33	832	650
		16 or thicker	33	1172	915
			50	1680	1312

Notes:

- 1 Screws shall be attached in the pre-drilled holes provided.
- 2 The allowable values for F1 and F4 are to be used only when the clip leg is attached to the CFS framing. The screw pattern must be as shown above. The capacity of the attachment to other materials and structures must be checked separately.
- 3 This table is intended for use by qualified engineers only. It is the responsibility of the engineer to verify that the tabulated values apply to a specific connection application.
- 4 The screw diameter must be 0.19" (min.) for #10 screws.
- 5 The ultimate screw shear strength must be a minimum of 1400 lbs. for #10 screws.
- 6 Screws must be long enough so that at least three exposed threads are visible after installation.
- 7 Allowable loads have not been increased 33% for wind or seismic.
- 8 For connections made to 14 gauge (68mil), and 12 gauge (97mil), use the tabulated values for 16 gauge (54mil), 50ksi, when using TDSP (16 gauge). Similarly when TDSP (18 gauge) is used with thicker base materials, the values for 18 gauge x 33ksi are to be used.
- 9 It is the responsibility of the design professional to detail the drawings for proper clip attachment.
- 10 Contact ClarkDietrich at 888-437-3244 for technical assistance.

Typical Construction Details

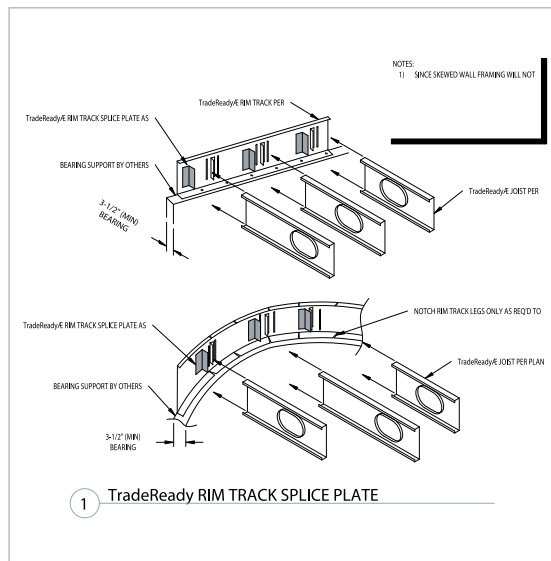
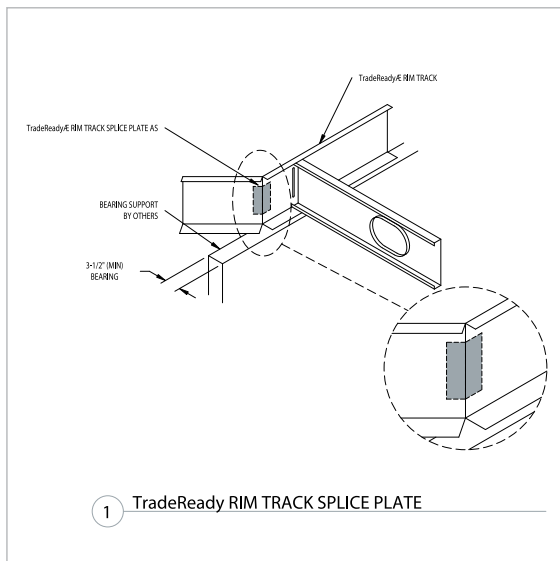

Visit our CAD Library at clarkdietrich.com to view or download construction details in .dwg, .dxf, and .pdf formats.