

CD/NSMF 120-04
ClarkDietrich™ Building Systems
Non-Loadbearing Wall Assemblies
Trakloc® Steel Framing System
ASTM E 119, CAN/ULC-S101
Rating: 2 Hours

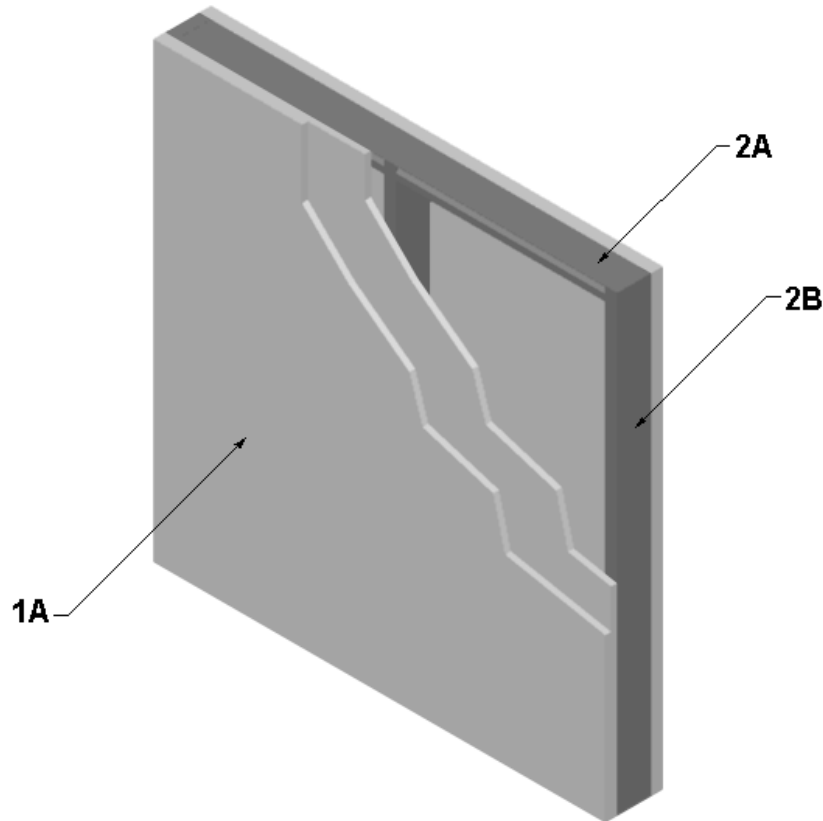

1. WALL ASSEMBLY – Construct 2-hour fire rated non-load bearing wall assembly positioned perpendicular to the floor ceiling assembly and consisting of the following elements:

- A. Gypsum Board – Cover studs with two layers of 5/8 in. thick Type X gypsum board, 4 ft wide, applied vertically with edges coincident with studs, or horizontally with nominal 1/8" gaps between boards. Joint compound (Item 1B) to be pressed into these gaps full board depth. Fasten base layer of gypsum board to steel studs (Item 2B) with Type S, 1-1/4 in. fine thread drywall screws,

spaced 16 in. on center (oc) along the perimeter and along all studs. Fasten face layer to studs with Type S, 1-5/8 in. fine thread drywall screws spaced 16 in. oc staggered 8 in. oc from the base layer fasteners.

- B. Joint Tape and Compound (Not shown) – Use vinyl or casein, dry or premixed joint compound applied to face layers of gypsum board (Item 1A) in two coats to all exposed fastener heads and gypsum board joints. Embed min 2 in. wide paper, plastic, or fiberglass tape in first

Division 09 – Finishes

09 22 00 Supports for Plaster and Gypsum Board

09 22 16 Non-Structural Metal Framing

layer of compound over joints in gypsum board.

2. Steel Framing System – Construct steel framing system using the following elements:

- A. CERTIFIED COMPANY:
ClarkDietrich™ Building Systems

CERTIFIED PRODUCT: Steel Floor Tracks and Ceiling Runners

MODEL: 362TTS137-18

STEEL FLOOR TRACKS AND CEILING RUNNERS: Use two “C-shaped” roll formed nominal 0.0179 inch minimum thick steel tracks each nominally 3-5/8 in. wide with two 1-3/8 in. vertical legs. Use nominal 3/16 in. diameter, 1-1/4 in. long, hex head concrete screws spaced 24 in. oc, to attach one track to the bottom of floor/ceiling assembly at the top of the floor and the other track to the bottom of the floor, aligned with the top track.

- B. CERTIFIED COMPANY:
ClarkDietrich™ Building Systems

CERTIFIED PRODUCT:
Telescoping Stud Deflection

MODEL: 362TSD125-18
(Telescoping Stud Assembly),
362TSD125-18 (Stud) and
362TSE125-18 (Extension stud)

Steel Studs – Use “C-shaped” roll formed nominal 0.0179 in. minimum thick steel studs (telescoping stud deflection) nominally measuring 3-5/8 in. wide with two 1-1/4 in. vertical legs. The telescoping stud assembly consists of a stud and an extension stud. “Twist-and-lock” steel stud framing into the steel floor tracks and ceiling runners (Item 2A) at a maximum 24 in. oc. No fasteners are required to secure the telescoping stud assembly to the steel floor tracks and ceiling runners (Item 2A).

3. JOINT TREATMENT – Not shown. Optional – Use when deflection movement required. Apply materials bearing an Intertek Certification Mark applied in accordance with their fire-resistive joint Design Listing.

- A. JOINT PACKING MATERIAL – Fill the joint created between the floor/ceiling assembly and the top edge of the Type X 5/8 in. thick gypsum board with a nominal 4 pcf mineral wool insulation. Create a nominal 1/4 in. recess from the exposed face of the Type X 5/8 in. thick gypsum board.

- B. FILL, VOID OR CAVITY MATERIAL
Fill the nominally measuring 1/4 in. deep recess with a fire rated sealant. Trowel-apply the sealant over all of the packing material overlapping the sealant onto the Type X 5/8 in. thick gypsum board.