

DEEP LEG DEFLECTION TRACK SYSTEMS

Head-of-wall vertical deep leg deflection track systems are required to allow the top of the wall stud to float within the top track legs. This condition allows for vertical live load movement of the primary structure without transferring axial loads to the interior drywall studs. A gap (determined by the Engineer of Record) is required between the top of the wall stud and the deflection track. ProSTUD® Drywall Framing studs can be used with the three Deep Leg Track Systems listed below:

ProTRAK® Deep Leg Track

ProTRAK deep leg track is available with leg lengths of 2", 2-1/2" and 3" long. The wall studs are not fastened to the deflection track, and a row of lateral bracing is required within 12" of the deep leg track to prevent rotation and lateral movement of the studs. The deflection track system must be designed for the end reaction of the wall studs (point loads) and for the specific gap required for vertical deflection.

ProTRAK® Allowable Lateral Loads and Wall Heights

Deflection track system	2" Leg Track with 1/2" Gap		2-1/2" Leg Track with 3/4" Gap		3" Leg Track with 1" Gap	
	Allowable load (lbs)	Limiting wall height	Allowable load (lbs)	Limiting wall height	Allowable load (lbs)	Limiting wall height
ProTRAK 25	36	10' 8"	24	7' 2"	18	5' 4"
ProTRAK 20	52	15' 6"	34	10' 4"	26	7' 9"
ProTRAK 30MIL	92	27' 6"	61	18' 4"	46	13' 9"
ProTRAK 33MIL	113	33' 10"	75	22' 7"	56	16' 11"

Notes:

- Limiting wall heights are based on studs spaced at 16" o.c. and an interior lateral load of 5psf.
- Stud members must be analyzed independently of the track system. Use www.iProSTUD.com to check limiting wall heights for ProSTUD members.
- Stud failure modes relating to the deflection track connection (shear, web crippling, etc.) must be checked separately.

Structural Deep Leg Track (18ga & 16ga)

Structural Deep Leg Track systems are installed the same as the ProTRAK deep leg track system but are designed to handle tall wall systems.

For structural deep leg track allowable loads, contact Technical Services at 888-437-3244 or visit clarkdietrich.com.

Slotted Deflection Track from ClarkDietrich

The slotted deflection track is attached to the wall studs through vertical slots using wafer head screws, creating a positive connection that allows for vertical movement and also eliminates the requirement for lateral bracing near the top of the wall stud.

MaxTrak® Allowable Lateral Loads and Wall Heights

Deflection track system	ProSTUD 25 (15mil, 50ksi)		ProSTUD 20 (18mil, 70ksi)		ProSTUD 30mil (33ksi)		ProSTUD 33mil (33ksi)	
	Allowable load (lbs)	Limiting wall height	Allowable load (lbs)	Limiting wall height	Allowable load (lbs)	Limiting wall height	Allowable load (lbs)	Limiting wall height
MaxTrak 30MIL	45	13' 6"	76	22' 10"	148	44' 4"	148	44' 4"
MaxTrak 33MIL	52	15' 7"	88	26' 5"	156	46' 10"	156	46' 10"

Notes:

- Allowable loads are based on screws through the slots located 1-1/4" from the track web.
- #8 minimum wafer head screws shall be used for stud-track connection.
- The above table is applicable to ProSTUD members only. ProSTUD allowable heights must be checked also.
- Allowable heights are based on 5psf and wall stud spacing at 16" o.c. with a max. gap of 7/8"

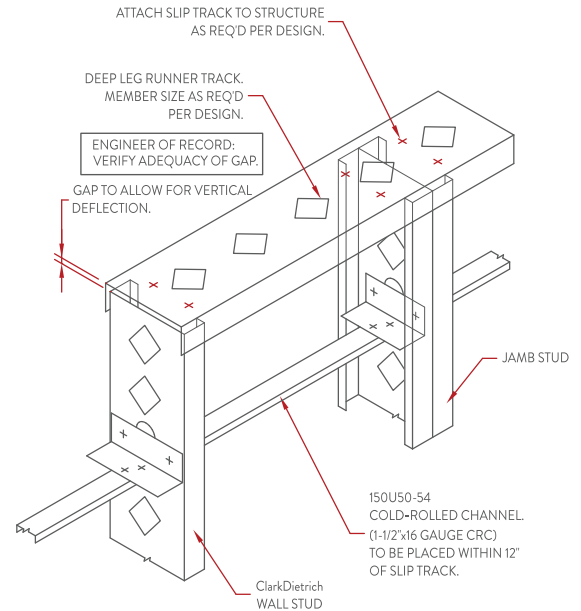

1 DEEP LEG DEFLECTION TRACK DETAIL WITH LATERAL BRACING WITHIN 12" OF SLIP TRACK

Details shown are for example only. The engineer of record of the project is responsible for the design of the connection to the structure. Additional connection details can be found at clarkdietrich.com.

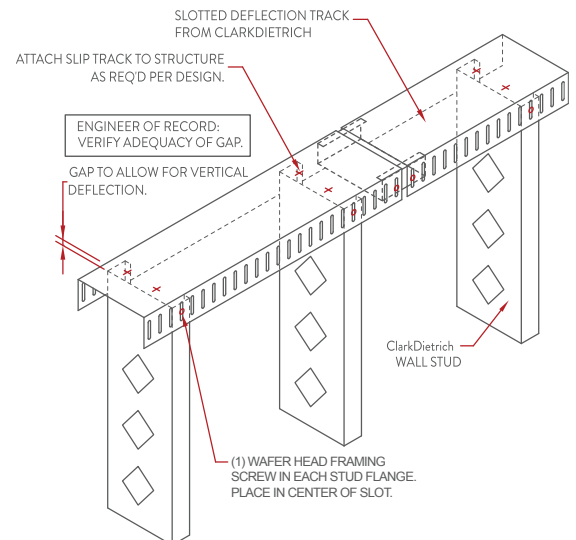

2 SLOTTED DEFLECTION TRACK DETAIL WITH TRACK SPLICE

ClarkDietrich offers both the MaxTrak® Slotted Deflection Track and BlazeFrame® Integrated Fire Stop System. Find more information on these systems at clarkdietrich.com.