

**STRONGER  
THAN STEEL.<sup>SM</sup>**

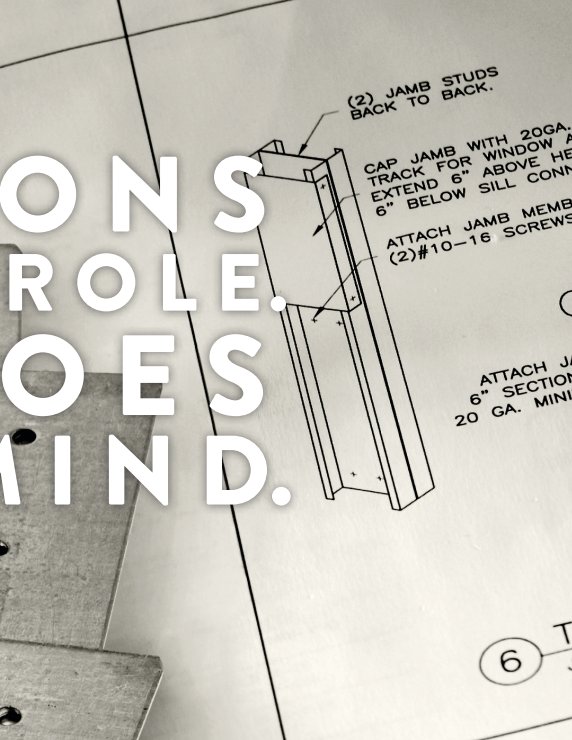

# CONNECTIONS PLAY A VITAL ROLE. AND SO DOES PEACE OF MIND.

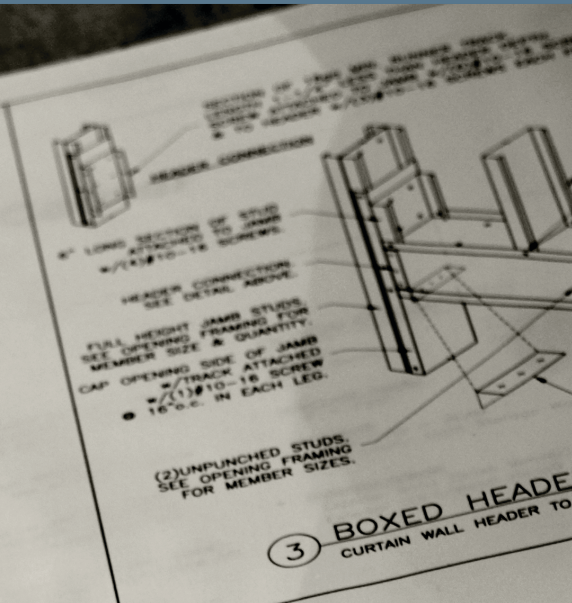
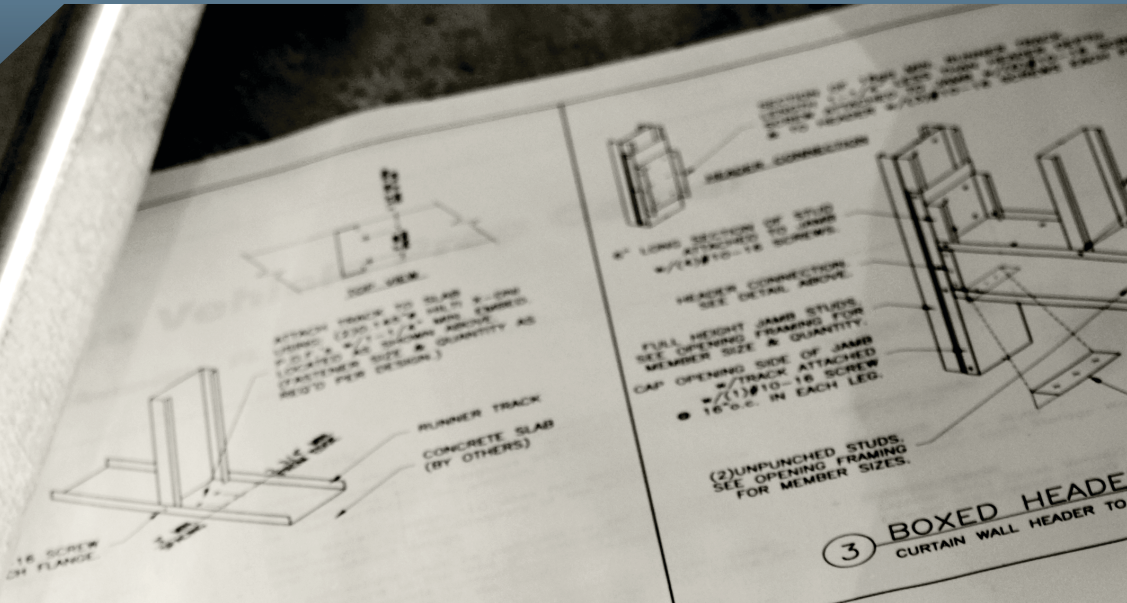

### **ClarkDietrich Clip Express<sup>SM</sup> stands alone**

in the industry. The vast lineup of products, quick delivery service and philosophy are unique in every respect—and especially in sum total. That's because Clip Express was created to give our customers an unmatched level of confidence.

#### **EVERYTHING YOU NEED FROM ONE CONVENIENT SOURCE.**

We know that having the right products, at the right time, and at the right price is absolutely essential to getting the job done. Clip Express is a single source for the industry's widest and most cost-effective array of rigid, deflection, bridging, and general-purpose clips, connectors, supports and framing hardware for commercial and residential cold-formed steel framing.

#### **CONSISTENT, HIGH-QUALITY PRODUCTS.**

When you design or specify by ClarkDietrich product name or number, you get fully engineered and rigorously tested systems and connectors—the same precision-formed products each and every time. It's exactly the kind of thing you'd expect from a partner like ClarkDietrich. The products we manufacture—like FastClip<sup>TM</sup> Slide Clips and Fast Top<sup>TM</sup> Clips—are created specifically to work as a system. It's an approach that leads to enhanced performance on the job.

#### **VALUE THAT CONTRIBUTES TO YOUR BOTTOM LINE.**

While you may find a cheaper price than ClarkDietrich, you won't find a lower overall cost or better value. We offer unmatched service through numerous plants and engineering offices—and nationwide product availability. From technical assistance to complete engineering services, we've truly put together an incredible array of resources to help you be successful on any project. This catalog is a great example. It's one of the most comprehensive light-gauge steel connector, clip, support and framing hardware manuals or resources available.

#### **CONNECTIONS YOU CAN COUNT ON.**

If getting what you want, when and how you want it is a must, ClarkDietrich Clip Express is ready to deliver. In fact, a wide array of shipping options is available, from standard ground to overnight. If we get your order today, you can get it tomorrow.

Count on ClarkDietrich to deliver products, systems and services that keep your costs down and productivity up.

**Need help with product selection, ordering, scheduling, delivery, or anything else? Call the Clip Express sales team:**

**Clip Express—866-638-1908**

**Need Product Submittals?  
Use [SubmittalPro](#)<sup>®</sup> at [clarkdietrich.com](#).**



## TABLE OF CONTENTS

<b>Overview</b>	2-11
Custom-Fabricated Specialty Products	2-3
Fastening Options	4-6
General Notes	7
How To Use This Catalog	8-9
Product Information	10
Support and Services	11
<b>Deflection Connectors</b>	12-43
<b>Drift Connections</b>	44-71
<b>Rigid Connections</b>	72-119
<b>Floor Framing Connections</b>	120-137
<b>Bridging, Bracing and Backing</b>	138-161
<b>Roof and Truss Connections</b>	162-169
<b>Specialty Clips and Accessories</b>	170-191
<b>Typical Construction Details</b>	192-193
<b>Index</b>	194-195
<b>Clip Express<sup>SM</sup> Display Program</b>	196
<b>Trademarks and Warranty</b>	196
<b>Code Approvals</b>	197
<b>Locations</b>	197

## Custom-Fabricated Specialty Products

When the job calls for a connection, clip or support that doesn't exist in this catalog, ClarkDietrich can create whatever you need. We can custom fabricate just about any shape, bend, angle or specialty framing clip, connector or support to your exact specification. Manufactured using precision cutting and forming equipment, a diverse selection of specialized sizes and shapes is available—including prepunched holes and/or specialized slots. Simply submit your dimensioned drawings to your ClarkDietrich representative, and we'll do the rest!

**Note:** The performance and installation of custom-made products is the sole responsibility of the design professional and engineer of record. Any customer ordering a custom-fabricated clip, connector or support shall indemnify, defend and hold harmless ClarkDietrich and ClarkDietrich Engineering Services for any loss or damage arising in whole or in part.

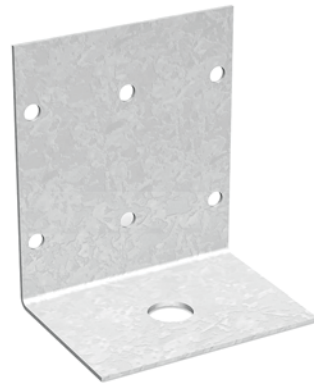
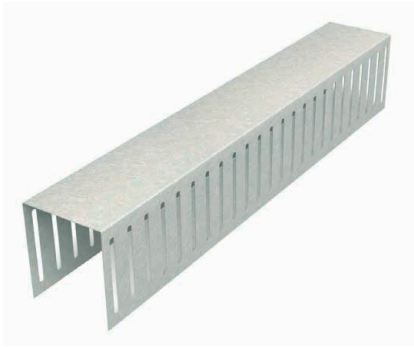
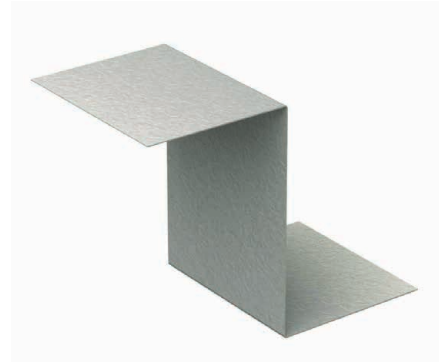
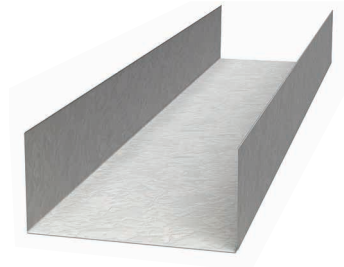

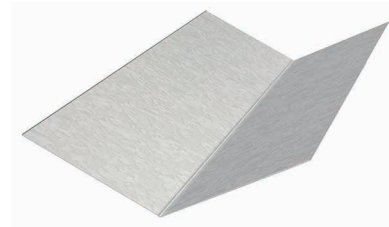
**MATERIAL SPECIFICATIONS****Gauge:** 25 gauge (18mils)**Design Thickness:** 0.0188 inches**Coating:** G40 or equivalent**Yield Strength:** 33ksi**ASTM:** C645, A653/A653M**AISI:** S220**Gauge:** 20 gauge (33mils)**Design Thickness:** 0.0346 inches**Gauge:** 18 gauge (43mils)**Design Thickness:** 0.0451 inches**Gauge:** 16 gauge (54mils)**Design Thickness:** 0.0566 inches**Gauge:** 14 gauge (68mils)**Design Thickness:** 0.0713 inches**Gauge:** 12 gauge (97mils)**Design Thickness:** 0.1017 inches**Gauge:** 10 gauge (118mils)**Design Thickness:** 0.1242 inches**Coating:** CP90 or CP60

Must be specified at the time of order placement.

**Yield Strength:** 50ksi or 33ksi

Must be specified at the time of order placement.

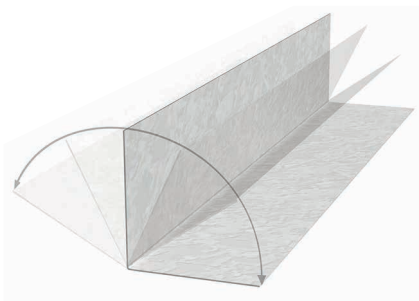
**ASTM:** A653/A653M, C955**AISI:** S240**INSTALLATION**

Will vary based upon application. Consult the engineer of record.

## Fastening Options

Connections can be made using a variety of fastening options. It is critical to specify the proper fastener to ensure the proper performance of the connections in light-gauge (cold-formed) steel construction. The most common and widely used connection methods are screw connections, powder-actuated fastener connections and weld connections. Each type of connection method has various advantages and disadvantages. Therefore, we provide data for the most common types so you can choose your preferred connection method.

### SCREW CONNECTIONS

**Self-drilling screws**—These high-strength fasteners are used if the connection is multiple thicknesses of 33mils steel or thicker. One of the more common self-drilling screws is a #10-16 x 5/8 HWH SD (#10 diameter shaft, 16 threads per inch, 5/8 length, hex washer head self-drilling screw).



### AISI Calculated Allowable Loads for Screw Connection

Material thickness (mils)	Design thickness (in)	Material Strength		#8-18 HWH Screw		#10-16 HWH Screw		#12-14 HWH Screw		1/4"-14 HWH Screw	
				Dia. = 0.160		Dia. = 0.190		Dia. = 0.210		Dia. = 0.240	
		Fy (ksi)	Fu (ksi)	Shear (lbs)	Tension (lbs)	Shear (lbs)	Tension (lbs)	Shear (lbs)	Tension (lbs)	Shear (lbs)	Tension (lbs)
33	0.0346	33	45	162	71	177	84	186	93	199	106
43	0.0451	33	45	241	92	263	109	277	121	296	138
54	0.0566	33	45	333	115	370	137	389	152	416	173
	0.0566	50	65	333	167	467	198	562	219	600	250
68	0.0713	33	45	—	—	467	173	550	191	588	218
	0.0713	50	65	—	—	467	249	667	276	849	315
97	0.1017	33	45	—	—	467	246	667	272	867	311
	0.1017	50	65	—	—	467	356	667	393	867	450
118	0.1242	33	45	—	—	—	—	667	333	867	380
	0.1242	50	65	—	—	—	—	667	480	867	549

### AISI Calculated Allowable Bearing & Pullover for Screws

Material thickness (mils)	Design thickness (in)	Material Strength		#8-18 Screw		#10-16 Screw		#12-14 Screw		1/4"-14 Screw	
				Shank = 0.160		Shank = 0.190		Shank = 0.210		Shank = 0.240	
		Fy (ksi)	Fu (ksi)	Bearing (lbs)	Pullover (lbs)	Bearing (lbs)	Pullover (lbs)	Bearing (lbs)	Pullover (lbs)	Bearing (lbs)	Pullover (lbs)
33	0.0346	33	45	224	195	266	292	294	292	336	389
43	0.0451	33	45	292	254	347	381	384	381	438	507
54	0.0566	33	45	367	318	436	478	481	478	550	637
		50	65	530	460	629	690	695	690	795	920
68	0.0713	33	45	—	—	549	602	606	602	693	802
		50	65	—	—	792	869	876	869	1001	1159
97	0.1017	33	45	—	—	783	858	865	858	989	1144
		50	65	—	—	1130	1239	1249	1239	1428	1653
118	0.1242	33	45	—	—	—	—	1056	1048	1207	1397
		50	65	—	—	—	—	1526	1514	1744	2018

**Notes:**

- All values were calculated using the 2001 AISI Specification w/2004 supplement.
- Charts are based on Buildex TEK2 HWH screw capacities. All screws must meet minimum criteria outlined.
- Shear strength for #8, #10, #12, and 1/4" screws must be greater than or equal to 1000 lbs, 1400 lbs, 2000 lbs and 2600 lbs respectively.
- Tension strength for #8, #10, #12, and 1/4" screws must be greater than or equal to 1545 lbs, 1936 lbs, 2778 lbs and 4060 lbs respectively.
- The minimum head diameter for #8 screws is 1/4". The minimum head diameter for #10 and #12 screws is 3/8". The minimum head diameter for 1/4" screws is 1/2".
- Screw ultimate shear capacity is based on Buildex® DATA as a minimum.
- Buildex is a registered trademark of Illinois Tool Works, Inc.



**Proprietary deflection screws**—Many of the ClarkDietrich deflection clips include our Proprietary Deflection Screw that has been specifically designed to provide friction-free deflection. These fasteners eliminate drag, binding or resistance that can often occur with common fasteners.

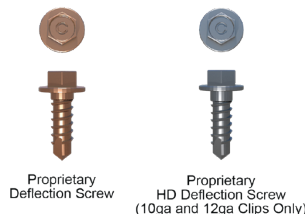

Proprietary Deflection Screw & Proprietary HD Deflection Screw	
Average Ultimate Shear	2400 lbs
AISI S100 Factor of Safety (ASD)	3.0
Average Allowable Shear Load	800 lbs



**POWDER-ACTUATED FASTENERS**

Powder-actuated, or low-velocity driven fasteners, are commonly used to attach cold-formed steel framing members to concrete or structural steel supports. PAF pins are used for permanent attachments and are the most common type used for cold-formed construction.



Powder-Actuated Fasteners Allowable Loads				IN NORMAL WEIGHT CONCRETE (LBS)											
Material thickness (mils)	Yield strength Fy (ksi)	Bearing (lbs)	Pullover (lbs)	PAF (Shank Dia.=0.145"; Head Dia.=0.3") Min. Embedment 3/4"						PAF (Shank Dia.=0.145"; Head Dia.=0.3") Min. Embedment 1"					
				2000psi		3000psi		4000psi		2000psi		3000psi		4000psi	
				Shear	Tension	Shear	Tension	Shear	Tension	Shear	Tension	Shear	Tension	Shear	Tension
33	33	203	234	95	70	110	90	125	110	140	90	160	120	185	155
43	33	265	304	95	70	110	90	125	110	140	90	160	120	185	155
54	33	333	382	95	70	110	90	125	110	140	90	160	120	185	155
	50	480	552	95	70	110	90	125	110	140	90	160	120	185	155
68	33	418	481	95	70	110	90	125	110	140	90	160	120	185	155
	50	604	695	95	70	110	90	125	110	140	90	160	120	185	155
97	33	597	686	95	70	110	90	125	110	140	90	160	120	185	155
	50	863	992	95	70	110	90	125	110	140	90	160	120	185	155
118	33	729	838	95	70	110	90	125	110	140	90	160	120	185	155
	50	1054	1211	95	70	110	90	125	110	140	90	160	120	185	155

Powder-Actuated Fasteners Allowable Loads				IN STRUCTURAL STEEL (LBS)											
Material thickness (mils)	Yield strength Fy (ksi)	Bearing (lbs)	Pullover (lbs)	PAF (Shank Dia.=0.145"; Head Dia.=0.3")											
				3/16"		1/4"		3/8"		1/2"		3/4"			
				Shear	Tension	Shear	Tension	Shear	Tension	Shear	Tension	Shear	Tension		
33	33	203	234	425	455	620	800	680	810	605	850	545	500		
43	33	265	304	425	455	620	800	680	810	605	850	545	500		
54	33	333	382	425	455	620	800	680	810	605	850	545	500		
	50	480	552	425	455	620	800	680	810	605	850	545	500		
68	33	418	481	425	455	620	800	680	810	605	850	545	500		
	50	604	695	425	455	620	800	680	810	605	850	545	500		
97	33	597	686	425	455	620	800	680	810	605	850	545	500		
	50	863	992	425	455	620	800	680	810	605	850	545	500		
118	33	729	838	425	455	620	800	680	810	605	850	545	500		
	50	1054	1211	425	455	620	800	680	810	605	850	545	500		

**Notes:**

- 1 Bearing and pullover values were calculated using the 2001 AISI Specification w/2004 supplement.
- 2 See General Note #6 on page 9 for additional information.

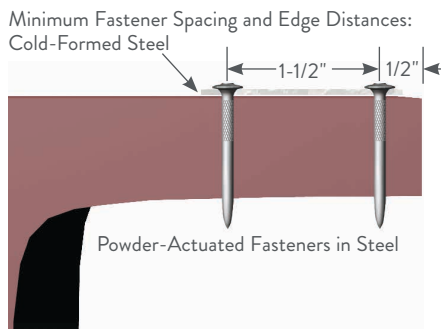
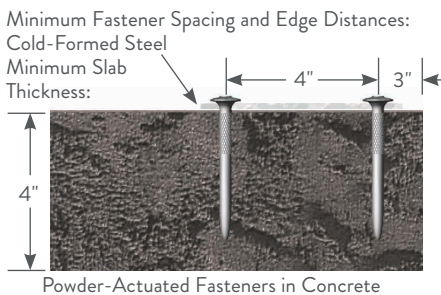

## Fastening Options

### WELDED CONNECTIONS

**Fillet welds**—Used to make lap joints, corner joints and T-joint connections.

Weld metal is deposited in a corner formed by the fit-up of the two members and penetrates and fuses with the base metal to form the joint.



Fillet Welds

**Flare welds**—Used to join rounded or curved pieces.

- A Flare Bevel groove weld is commonly used to join a rounded or curved piece to a flat piece.
- A Flare V groove weld is commonly used to join two rounded or curved parts.



Flare Bevel

Flare V

**Note:** For graphical clarity, the weld illustrations do not show the penetration of the welded material. Weld penetration is critical in determining the quality of the weld.

### AISI Allowable Loads for Welded Connections

Material thickness (mils)	Design thickness (in)	Material Strength		Fillet Weld		Flare Groove Weld	
		F <sub>y</sub> (ksi)	F <sub>u</sub> (ksi)	Longitudinal (lbs)	Transverse (lbs)	Longitudinal (lbs)	Transverse (lbs)
Values for a single one (1) inch weld							
43	0.0451	33	45	619	864	544	663
	0.0451	50	65	895	1247	785	958
54	0.0566	33	45	822	1084	682	832
	0.0566	50	65	1188	1566	985	1202
68	0.0713	33	45	1082	1365	859	1048
	0.0713	50	65	1563	1972	1241	1514
97	0.1017	33	45	1480	1480	1226	1480
	0.1017	50	65	1480	1480	1480	1480
118	0.1242	33	45	1808	1808	1497	1808
	0.1242	50	65	1808	1808	1808	1808
Values for a single two (2) inch weld							
43	0.0451	33	45	998	1727	1087	1326
	0.0451	50	65	1442	2495	1570	1915
54	0.0566	33	45	1253	2168	1364	1664
	0.0566	50	65	1809	3131	1971	2404
68	0.0713	33	45	1578	2731	1719	2096
	0.0713	50	65	2279	3944	2483	3028
97	0.1017	33	45	2884	2961	2452	2961
	0.1017	50	65	2961	2961	2961	2961
118	0.1242	33	45	3616	3616	2994	3616
	0.1242	50	65	3616	3616	3616	3616
Values for a single three (3) inch weld							
43	0.0451	33	45	1497	2591	1631	1989
	0.0451	50	65	2163	3742	2356	2873
54	0.0566	33	45	1879	3251	2047	2496
	0.0566	50	65	2714	4697	2956	3605
68	0.0713	33	45	2367	4096	2578	3144
	0.0713	50	65	3419	5916	3724	4542
97	0.1017	33	45	3376	4441	3678	4441
	0.1017	50	65	4441	4441	4441	4441
118	0.1242	33	45	4987	5424	4491	5424
	0.1242	50	65	5424	5424	5424	5424

**Notes:**

- 1 All values were calculated using the 2001 AISI Specification w/2004 supplement (Section E2).
- 2 F<sub>xx</sub> values were based off of F<sub>xx</sub> >= 70ksi and that F<sub>xx</sub> > F<sub>u</sub>.
- 3 Values include a factor of safety that varies depending on the AISI code calculation used.
- 4 Longer weld values can be found by following the AISI Specification or by calling Technical Services at 888-437-3244; however, using multiples of lengths shown for longer welds may result in incorrect values.
- 5 Weld values listed are based on a minimum effective throat of .707 times the design thickness.

## General Notes

- 1 Install products per installation instructions detailed in this catalog.
- 2 Install all connectors and fasteners before load application.
- 3 Do not modify, change or alter any connector in this catalog.
- 4 Do not bend connectors unless they are specifically designed to be bent. Connectors that are not designed to be bent may fracture. Fractured steel will not carry load and must be replaced. Connectors that are designed to be bent shall only be bent one time.
- 5 Install fasteners per the manufacturer's instructions.
- 6 Load tables have been developed using the following fastener data:
  - Powder-Actuated Fastener (PAF)–Minimum shank diameter of 0.145" with a minimum head diameter of 0.300" placed in 3/16" steel minimum. All PAF pins must have a 5.0 safety factor and an allowable capacity greater than the values shown in the allowable load charts herein, either as a single pin or in multiples per each chart.
  - Design capacities of PAF fasteners used with light gauge steel connectors must comply with the provision of AISI S100 (2016) Section J5 Power-Actuated (PAF) Connections, as well as the PAF manufacture's design guidelines.
  - Hilti\* Kwik-Con II–Reference 2011 Edition of the Hilti North American Product Technical Guide, Volume 2, page 340.
- #10-16 Screws–Capacities as calculated according to the AISI North American Specification for the Design of Cold-Formed Steel Members. The ultimate nominal screw shear capacity must be 1400# or greater.
- For additional allowable load tables and fastener options, please visit [clarkdietrich.com](http://clarkdietrich.com).
- 7 Tabular footnotes must be followed and supersede general notes when in conflict.
- 8 Fasteners other than those specified may be substituted with the approval of the engineer of record.
- 9 Allowable loads and material data listed in this catalog supersedes all information in previous publications.
- 10 Allowable loads, in some cases, have been increased by one-third per allowable codes. It is important to verify that the actual installation meets the requirements to allow the one-third increase. If not, the engineer of record should adjust the loads down.
- 11 Listed loads are the maximum monotonic design loads to be applied to the connection based on testing or calculations. Load tables have been developed using Allowable Stress Design methodologies.
- 12 Allowable loads are the maximum forces applied in one direction only. When loads are applied in multiple directions, the engineer of record is responsible for verifying the maximum capabilities based on an appropriate interaction equation.
- 13 Where maximum movements (deflections) are specified, they are the total movement in both directions. The fastener positioning and size will affect the amount of allowable movement.
- 14 ClarkDietrich strongly recommends the following language be included in plans and specifications: "ClarkDietrich connectors were utilized in developing the plans and specifications for this project. Before substituting another brand, the engineer of record must verify the load capacities and approve the substitution in writing."
 

\*Hilti is a registered trademark of the Hilti Aktiengesellschaft Corporation.

**WARNING:** Handling of these products without the proper use of hand and eye protection may result in injury.

## How To Use This Catalog

This catalog is designed to help you select the right product or system for your construction applications. It is divided into seven major sections, with each one featuring a detailed building cutaway showcasing the products included in that section:

- Deflection Clips and Connections
- Drift Connections
- Rigid Connections
- Floor Framing Clips, Stiffeners, Supports and Hangers
- Bridging, Bracing and Backing Systems
- Roof and Truss Connections
- Specialty Clips and Fasteners

Example: Detailed building cutaway.

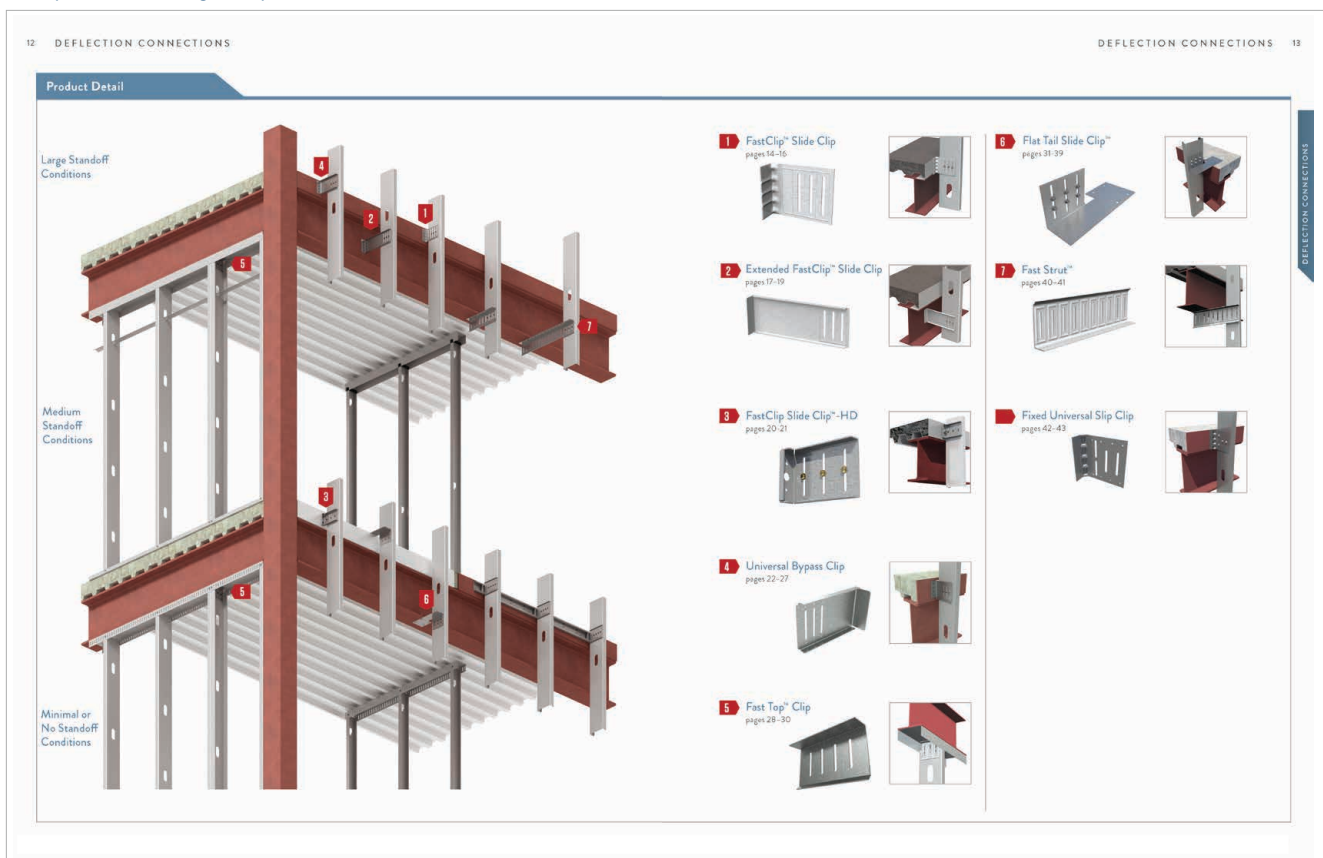

## COMPREHENSIVE INDEX

At the back of the catalog, you'll find a quick reference index to our complete product offering. This index includes common names and product names, as well as common acronyms, to help you quickly find exactly what you're looking for.

PRODUCT PAGES

Each product page includes: an extensive product overview, features and benefits, detailed fastening instructions and patterns, in addition to the information shown below.

Product Name and Code

Installation Instructions

Sizing and Packaging Information

Product Illustrations with Dimensions

Load Table Notes

Load Tables

Application Illustrations

CAD Drawings

**NOT ALL LOAD TABLES ARE CREATED EQUAL**

It is critical that the allowable load tables for clips, connectors and fasteners are interpreted correctly—especially when comparing clip performance for a “ClarkDietrich or equal” specification. The allowable load for a clip assembly is governed by the capacity of the clip, plus the method of attachment to the structure. The ClarkDietrich tables include the attachment to the structure and not simply the clip capacity alone. When attaching a clip to the structure, the overall capacity can often be lower than the published value for the clip alone. Load tables that ignore the attachment to the structure essentially *imply that the clip or connector must be welded* to achieve the stated values. More often than not, clips and connectors will not be welded, based on installation quality and efficiency.

That’s why ClarkDietrich publishes values for the most common attachment methods—so the designer or engineer can have confidence that all load requirements have been satisfied. For example, the tabulated values ClarkDietrich provides for the FastClip™ includes data for commonly used PAFs and Buildex\* screws.

\*Buildex is a registered trademark of Illinois Tool Works, Inc.

Example: ClarkDietrich allowable load table.

Anchor type	Stud thickness and yield strength	No. anchors to structure	Allowable load (lbs)
Buildex #1/2-24 Tek 5 Self-Drilling Screws to 3/16" Steel	20ga (33mils) 33ksi	2	425
		3	425
		4	425
	18ga (43mils) 33ksi	2	852
		3	852
		4	852
	16ga (54mils) 50ksi	2	852
		3	852
		4	852
	14ga (68mils) 50ksi	2	852
		3	852
		4	852
12ga (97mils) 50ksi	2	852	
	3	852	
	4	852	
PAF to 3/16" Steel*	20ga (33mils) 33ksi	2	511
		3	587
		4	587
	18ga (43mils) 33ksi	2	511
		3	767
		4	852
	16ga (54mils) 50ksi	2	852
		3	852
		4	852
	14ga (68mils) 50ksi	2	852
		3	852
		4	852
12ga (97mils) 50ksi	2	852	
	3	852	
	4	852	

## Product Information

### PRODUCT LABELING

The majority of the connectors listed in this catalog are identified using a very simple alphanumeric product code system. Each clip, connector or support is clearly embossed with an identifiable code so the installer can easily identify and use the proper connection hardware. For the engineer or architect, the embossed markings provide a very easy way to field verify that the correct connector or hanger is used.

### PACKAGING

The majority of clips are packaged in distinct, easy-to-spot, blue buckets. Each bucket is clearly labeled with the product code, gauge, size, length, dimensions, piece counts, and any special markings as requested. Based on order quantity, buckets will be packed in skids for easy handling. Each skid will be clearly identified with master skid labels that display the same information as the buckets.



### PROTECTIVE COATINGS

Coating designations for the clip and connector products in this catalog are displayed in the material specification section for each product. Special coatings are available on request. For more information, please contact your sales representative.

### STEEL THICKNESS

The steel thickness of a connector, clip, support or hanger is referenced in terms of gauge or mils. The mils thickness measures the uncoated base metal material, and is a key contributor to the strength of the product.

*Note:* All products comply with ASTM and AISI standards and federal specifications as shown in the Code Approvals and Performance Standards in the back of this catalog. Minimum thickness is 95% of the design thickness, per AISI code. One mils is equivalent to 1/1000 (0.001) of an inch. So, a 20 gauge stud measuring the minimum uncoated base metal at 0.030 inches is 30 mils thick.

### Steel Thickness

Gauge	Mils	Design thickness	Minimum thickness
25	18	0.0188"	0.0179"
20 DW	30	0.0312"	0.0296"
20 STR	33	0.0346"	0.0329"
18	43	0.0451"	0.0428"
16	54	0.0566"	0.0538"
14	68	0.0713"	0.0677"
12	97	0.1017"	0.0966"
10	118	0.1242"	0.1180"

### YIELD STRENGTH (FY/PSI OR KSI)

The majority of clips, connectors, supports and framing hardware are manufactured from mil-certified, ASTM A1003 Structural Grade 50 Type H steel. KSI = kips/square inch = 1,000 lbs

### METRIC SPECIFICATIONS

At your request, ClarkDietrich will provide "soft" metric conversions on its products and systems to help specifiers match metric design sizes. In addition, some products are available with hard metric dimensions from selected manufacturing facilities.

## Support and Services

### CLARKDIETRICH ENGINEERING SERVICES

Smarter engineering and technical expertise.  
It's support that extends beyond the structure itself.

From the initial design phase to jobsite installation, we are all about providing inventive, yet practical and hands-on know-how to help you think outside the box—or to help you just get it done.

ClarkDietrich Engineering Services is a full-service consulting firm that believes strongly in value engineering and customer input. Our engineering fees and lead times are competitive, and our customer service exceeds the industry standard with consistent point-of-contact through our regional project managers.

We offer Building Information Modeling (BIM) services that include specialty engineering collaborative design. We support the BIM movement by offering add-on tools that allow our products, and the rich data attached to them, to quickly be imported into digital designs. Our team is also comprised of LEED®-accredited professionals to consult on sustainable building design.

- Electronically sealed shop drawings and calculations
- Preliminary sizing and pre-bid engineering pricing
- Reference plan on large projects
- Detailed wall sections, full elevation opening design and C-stud truss design

Our technical services team provides immediate response to questions ranging from general installation to detailed specification requirements, and can deliver one-day turnaround on technical sizing. We are experts on industry standards such as AISI, ASTM and SFIA. Our team also supports our online product submittal system, SubmittalPro®, and our design/engineering software is available as a free download from [www.clarkdietrich.com](http://www.clarkdietrich.com).

- Product support and typical member sizing
- Framing detail recommendations
- Compliance and industry standards, such as AISI, ASTM and SFIA
- Engineering software and product submittal support
- LEED requirements support



### ClarkDietrich Engineering Services

Toll-Free Phone: 877.832.3206  
Toll-Free Fax: 877.832.3208  
Technical Services: 888.437.3244  
Email: [engineering@clarkdietrich.com](mailto:engineering@clarkdietrich.com)

**CENTRAL** Crown Point, IN  
**NORTHEAST** Bristol, CT

**SOUTHEAST** McDonough, GA  
**WEST** Carlsbad, CA

Product Detail

Large Standoff Conditions

Medium Standoff Conditions

Minimal or No Standoff Conditions

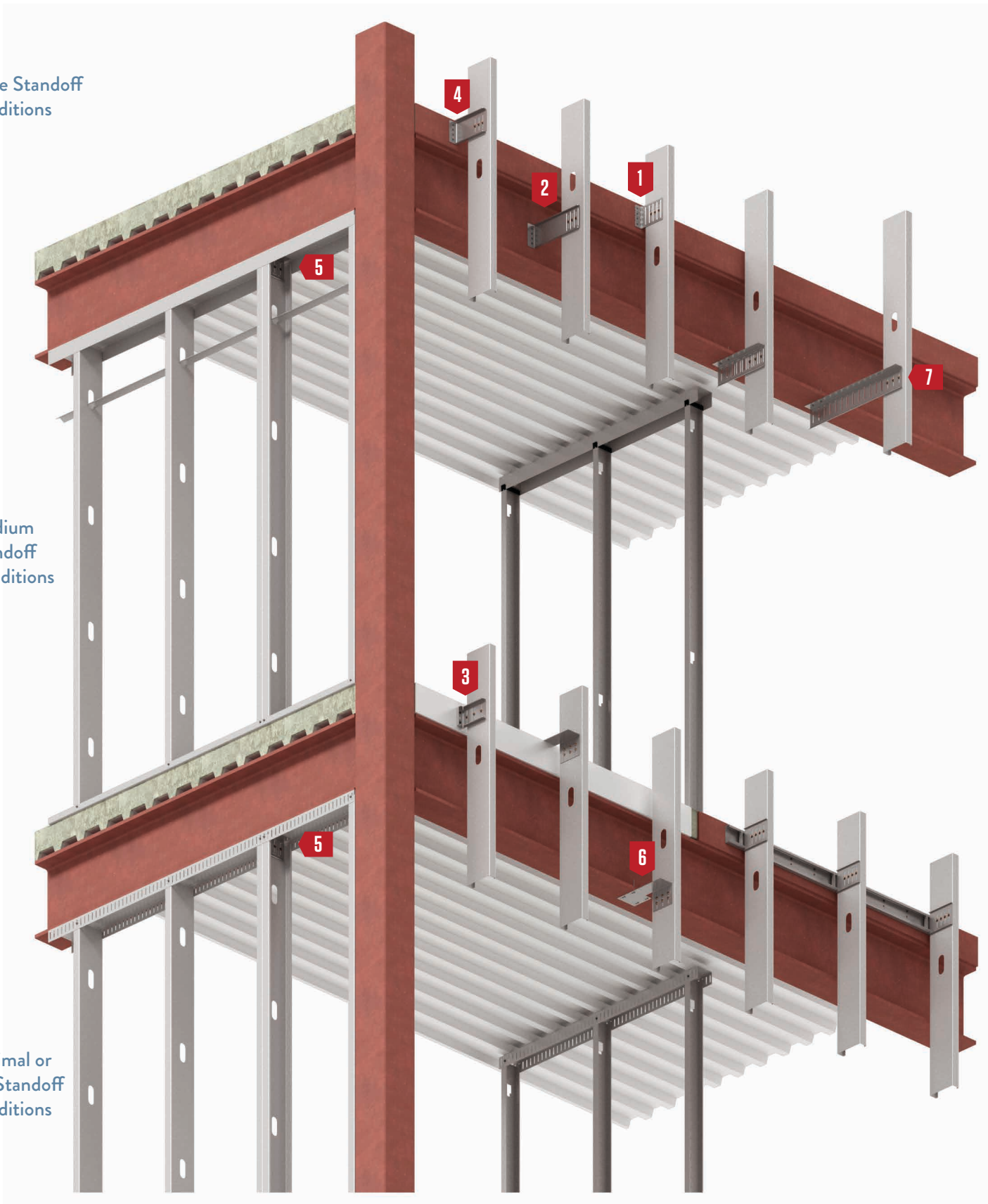



**1** FastClip™ Slide Clip  
pages 14–16

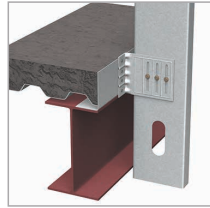
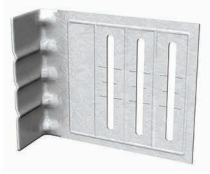

**2** Extended FastClip™ Slide Clip  
pages 17–19

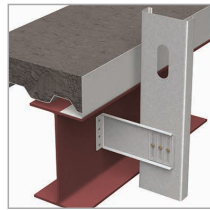

**3** FastClip Slide Clip™-HD  
pages 20–21

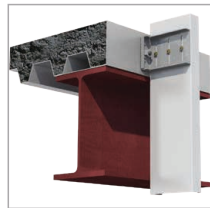
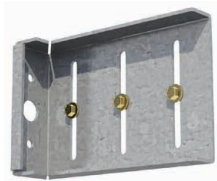

**4** Universal Bypass Clip  
pages 22–27



**5** Fast Top™ Clip  
pages 28–30



**6** Flat Tail Slide Clip™  
pages 31–39

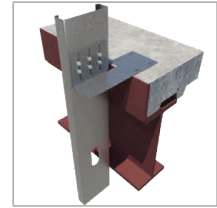

**7** Fast Strut™  
pages 40–41



**Fixed Universal Slip Clip**  
pages 42–43

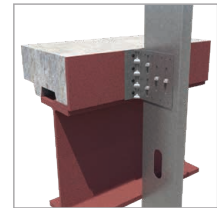

## FastClip™ Slide Clip

Curtain Wall/Bypass

### Vertical building movement up to 3"

ClarkDietrich FCSC deflection clips are used to attach exterior curtain wall studs to the building structure and provide for vertical building movement independent of the cold-formed steel framing. A ClarkDietrich FastClip™ deflection clip installs quickly with screws or powder-actuated fasteners, and provides adjustable standoff to ensure a plumb wall plane. Proprietary Deflection Screws are provided with each clip to ensure friction-free sliding. Each clip is also embossed with fastening patterns to ensure accurate placement of fasteners.

#### MATERIAL SPECIFICATIONS

**Gauge:** 14 gauge (68mils)

**Design Thickness:** 0.0713 inches

**Gauge:** 12 gauge (97mils)

**Design Thickness:** 0.1017 inches

**Coating:** G90

**Yield Strength:** 50ksi

**ASTM:** A653/A653M

#### PRODUCT DIMENSIONS

3-1/2" FastClip: 1-1/2" x 3-1/2" x 4-1/2"

5-1/2" FastClip: 1-1/2" x 5-1/2" x 4-1/2"

#### ALTERNATIVE PRODUCTS

Fast Strut™

Flat Tail™

FastClip™ HD

Universal Bypass Clip

#### INSTALLATION

Connections to the building can be made with screws, powder-actuated fasteners or drill-in concrete anchors. Mechanical fasteners shall be located on the embossed marks given on the scored line of the 1-1/2" flange. Two or three Proprietary Deflection Screws (based upon clip size) are used to attach the clip to the cold-formed steel framing. Screws shall be driven through the slotted holes and positioned to allow for the appropriate building deflection.

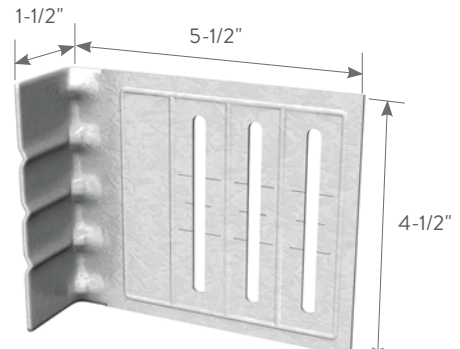
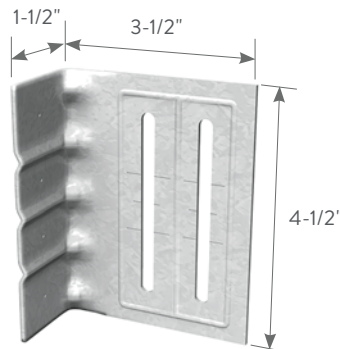
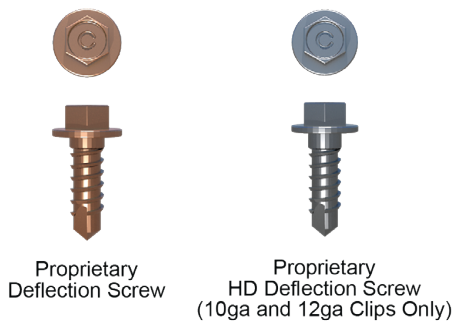

### FastClip™ Slide Clips (FCSC)

Product Code	Product Thickness		Size (in)	Packaging Pcs./Carton
	Mils (Gauge)	Design Thickness (in)		
FCSC3.5-68	68mils (14ga)	0.0713	1-1/2 x 3-1/2 x 4-1/2	25
FCSC5.5-68	68mils (14ga)	0.0713	1-1/2 x 5-1/2 x 4-1/2	25
FCSC5.5-97	97mils (12ga)	0.1017	1-1/2 x 5-1/2 x 4-1/2	25

3-1/2" FCSC includes 55 Proprietary Deflection Screws per carton.

5-1/2" FCSC includes 80 Proprietary Deflection Screws for 14ga clip and 80 Proprietary HD Deflection Screw for 12ga clip per carton.

Intertek CCRR-0208  
U.S. Patent No. 6,688,069

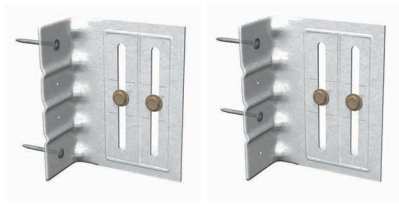

Location Options with (2) Anchors



Location Options with (3) Anchors

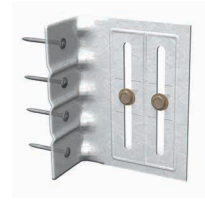

(4) Anchors

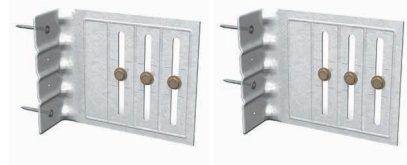

Location Options with (2) Anchors

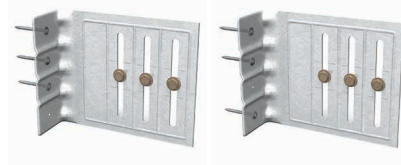

Location Options with (3) Anchors

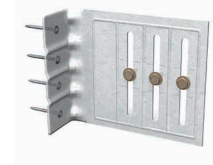

(4) Anchors

### 3-1/2" FastClip™ Allowable Loads (lbs)

Anchor Type	Stud Thickness / Yield Strength	No. Anchors to Structure	Allowable Load (lbs)
Buildex #12-24 Tek 5 Self-Drilling Screws to 3/16" Steel	33mils (20ga) 33ksi	2	425
		3	425
		4	425
	43mils (18ga) 33ksi	2	852
		3	852
		4	852
	54mils (16ga) 50ksi	2	852
		3	852
		4	852
	68mils (14ga) 50ksi	2	852
		3	852
		4	852
97mils (12ga) 50ksi	2	852	
	3	852	
	4	852	
PAF to 3/16" Steel*	20ga (33mils) 33ksi	2	511
		3	587
		4	587
	43mils (18ga) 33ksi	2	511
		3	767
		4	852
	54mils (16ga) 50ksi	2	852
		3	852
		4	852
	68mils (14ga) 50ksi	2	852
		3	852
		4	852
97mils (12ga) 50ksi	2	852	
	3	852	
	4	852	

### 5-1/2" FastClip™ Allowable Loads (lbs)

Anchor Type	Stud Thickness / Yield Strength	No. Anchors to Structure	Allowable Load (lbs)
Buildex #12-24 Tek 5 Self-Drilling Screws to 3/16" Steel	33mils (20ga) 33ksi	2	689
		3	689
		4	689
	43mils (18ga) 33ksi	2	852
		3	852
		4	852
	54mils (16ga) 50ksi	2	852
		3	852
		4	852
	68mils (14ga) 50ksi	2	852
		3	852
		4	852
97mils (12ga) 50ksi	2	852	
	3	852	
	4	852	
PAF to 3/16" Steel*	33mils (20ga) 33ksi	2	510
		3	689
		4	689
	43mils (18ga) 33ksi	2	510
		3	765
		4	852
	54mils (16ga) 50ksi	2	852
		3	852
		4	852
	68mils (14ga) 50ksi	2	852
		3	852
		4	852
97mils (12ga) 50ksi	2	852	
	3	852	
	4	852	

\*See General Note #6 on page 7 for the definition of PAF, minimum requirements and other additional information.

**Notes:**

- 1 The 1/3 stress increase for wind shall not be used.
- 2 Attach building anchors to the structure according to the manufacturer's instructions. Anchors shall be installed through the embossments on the scored line of the clip as shown on the drawings above. In no case shall anchors be installed more than 3/4" from the bend on the short leg of the clip. In cases of discrepancy between this information and the design engineer's details, the design engineer's details shall be followed.
- 3 It is the responsibility of the design professional to detail the project drawings for proper clip installation.
- 4 For connections to concrete, or other technical assistance, contact ClarkDietrich at 888-437-3244.
- 5 Buildex is a registered trademark of Illinois Tool Works, Inc.

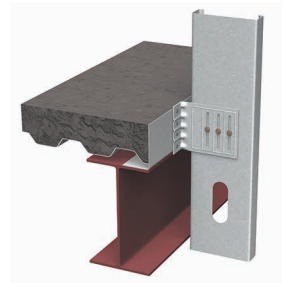

## 5-1/2" FastClip™ Slide Clip

## Curtain Wall/Bypass

## 5-1/2" 12ga FastClip™ (FCSC) Allowable Loads (lbs)

Anchor Type	Stud Thickness / Yield Strength	No. Anchors to Structure	Allowable Load* (lbs)	Allowable Load# (lbs)
Buildex #12-24 Self-Drilling Screws to 3/16" Steel	33mils (20ga) 33ksi	2	608	608
		3	608	608
		4	608	608
	43mils (18ga) 33ksi	2	905	905
		3	905	905
		4	905	905
	54mils (16ga) 50ksi	2	1004	1004
		3	1506	1506
		4	1553	1710
	68mils (14ga) 50ksi	2	1004	1004
		3	1506	1506
		4	1553	1710
97mils (12ga) 50ksi	2	1004	1004	
	3	1506	1506	
	4	1553	1710	
Hilti 0.157" X-U Powder-Actuated Fasteners (PAF) to 3/16" Steel	33mils (20ga) 33ksi	2	608	608
		3	608	608
		4	608	608
	43mils (18ga) 33ksi	2	905	905
		3	905	905
		4	905	905
	54mils (16ga) 50ksi	2	1064	1064
		3	1553	1596
		4	1553	1710
	68mils (14ga) 50ksi	2	1064	1064
		3	1553	1596
		4	1553	1710
97mils (12ga) 50ksi	2	1064	1064	
	3	1553	1596	
	4	1553	1710	
Generic Fasteners to 3/16" Steel	33mils (20ga) 33ksi	n	608	608
	43mils (18ga) 33ksi	n	905	905
	54mils (16ga) 50ksi	n	1553	1710
	68mils (14ga) 50ksi	n	1553	1710
	97mils (12ga) 50ksi	n	1553	1710
Ultimate Clip Capacity	33mils (20ga) 33ksi	—	1825	
	43mils (18ga) 33ksi	—	2715	
	54mils (16ga) 50ksi	—	5130	
	68mils (14ga) 50ksi	—	5130	
	97mils (12ga) 50ksi	—	5130	

**Notes:**

- 1 Tabulated allowable loads do not include a 1/3 stress increase for wind.
- 2 \* - Allowable capacity includes 1/8" service load limit.
- 3 # - Allowable capacity does not include 1/8" service load limit.
- 4 Mechanical fasteners should be attached to the structure in accordance with the manufacturer's instructions. All fasteners were assumed to be installed at a distance of 3/4" from the bend of the structural leg.
- 5 n - Number of generic mechanical fasteners required for connection to be determined by a design professional. Capacity should not exceed tabulated allowable loads.
- 6 Generic fastener capacities were calculated by considering clip-stud interaction, behavior of clip in tension and compression only. The design professional has to detail for clip and desired fastener installation.
- 7 Ultimate clip capacities were tabulated for the purpose of blast loads and they do not assume a safety factor.
- 8 Ultimate clip capacities were calculated by assuming that the structural leg of the clip fastened to 3/16" steel using (4) Buildex #12-24 fasteners or (4) Hilti X-U fasteners.
- 9 It is the responsibility of the design professional to detail the project drawings for proper clip and fastener installation.
- 10 Buildex is a registered trademark of Illinois Tool Works, Inc.
- 11 Hilti is a registered trademark of Hilti Aktiengesellschaft Corporation.

## Extended FastClip™ Slide Clip

Curtain Wall/Bypass

Vertical building movement up to 3", and commonly used for large standoff conditions.

ClarkDietrich FCEC deflection clips are used to attach exterior curtain wall studs to the building structure and provide for vertical building movement independent of the cold-formed steel framing. The clips are available in standard lengths of 6," 8," 10" and 12" and are ideal for medium to larger standoff conditions. Extended FastClip™ deflection clips install quickly with screws, welds or powder-actuated fasteners, and provide adjustable standoff to ensure a plumb wall plane. Proprietary Deflection Screws are provided with each clip to ensure friction-free sliding.

### MATERIAL SPECIFICATIONS

**Gauge:** 14 gauge (68mils)

**Design Thickness:** 0.0713 inches

**Coating:** G90

**Yield Strength:** 50ksi

**ASTM:** A653/A653M

### PRODUCT DIMENSIONS

6" Extended FastClip: 1-7/8" x 6" x 4-3/4"

8" Extended FastClip: 1-7/8" x 8" x 4-3/4"

10" Extended FastClip: 1-7/8" x 10" x 4-3/4"

12" Extended FastClip: 1-7/8" x 12" x 4-3/4"

### ALTERNATIVE PRODUCTS

Fast Strut™

Universal Bypass Clip

### INSTALLATION

Connections to the building can be made with screws, welds, powder-actuated fasteners or drill-in concrete anchors. Mechanical fasteners shall be located on the embossed marks given on the scored line of the 1-7/8" flange. Three Proprietary Deflection Screws are used to attach the clip to the cold-formed steel framing. Screws shall be driven through the slotted holes and positioned to allow for the appropriate building deflection.

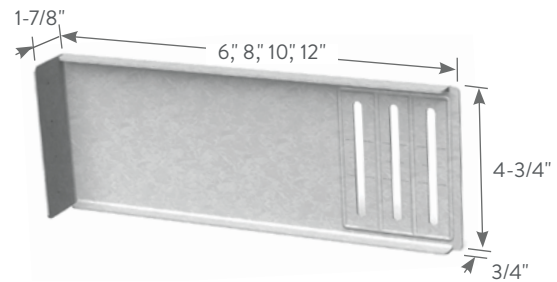

### Extended FastClip™ Slide Clip (FCEC)

Product Code	Product Thickness		Size (in)	Packaging Pcs./Bucket
	Mils (Gauge)	Design Thickness (in)		
FCEC6-68	68mils (14ga)	0.0713	1-7/8 x 6 x 4-3/4	25
FCEC8-68	68mils (14ga)	0.0713	1-7/8 x 8 x 4-3/4	25
FCEC10-68	68mils (14ga)	0.0713	1-7/8 x 10 x 4-3/4	25
FCEC12-68	68mils (14ga)	0.0713	1-7/8 x 12 x 4-3/4	25
FCEC8-97	97mils (12ga)	0.1017	1-7/8 x 8 x 4-3/4	25

Includes 80 Proprietary Deflection Screws for 14ga clip and 80 Proprietary HD Deflection Screw for 12ga clip per carton.

Intertek CCRR-0208  
U.S. Patent No. 6,688,069

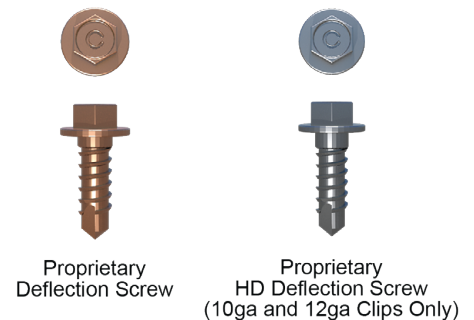

Extended FastClip™ Slide Clip

Curtain Wall/Bypass

Extended FastClip™ (FCEC) Allowable Loads (lbs)

Anchor Type	Stud Thickness / Yield Strength	No. Anchors to Structure	Allowable Load (lbs)
Buildex #12-24 Tek 5 Self-Drilling Screws to 3/16" Steel	33mils (20ga) 33ksi	2	689
		3	689
		4	689
	43mils (18ga) 33ksi	2	852
		3	852
		4	852
	54mils (16ga) 50ksi	2	852
		3	852
		4	852
	68mils (14ga) 50ksi	2	852
		3	852
		4	852
97mils (12ga) 50ksi	2	852	
	3	852	
	4	852	
PAF to 3/16" Steel*	33mils (20ga) 33ksi	2	689
		3	689
		4	689
	43mils (18ga) 33ksi	2	510
		3	765
		4	852
	54mils (16ga) 50ksi	2	852
		3	852
		4	852
	68mils (14ga) 50ksi	2	852
		3	852
		4	852
97mils (12ga) 50ksi	2	852	
	3	852	
	4	852	

\*See General Note #6 on page 7 for the definition of PAF, minimum requirements and other additional information.

Notes:

- 1 The 1/3 stress increase for wind shall not be used.
- 2 Attach building anchors to the structure according to the manufacturer's instructions. Anchors shall be installed through the embossments on the scored line of the clip as shown to the right. In no case shall anchors be installed more than 3/4" from the bend on the short leg of the clip. In cases of discrepancy between this information and the design engineer's details, the design engineer's details shall be followed.
- 3 It is the responsibility of the design professional to detail the project drawings for proper clip installation.
- 4 For connections to concrete, or other technical assistance, contact ClarkDietrich at 888-437-3244.
- 5 Buildex is a registered trademark of Illinois Tool Works, Inc.

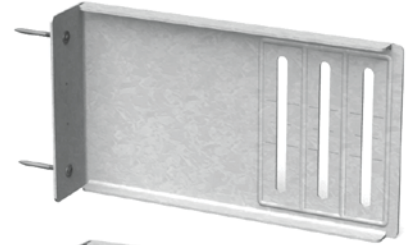

Location Options with (2) Anchors

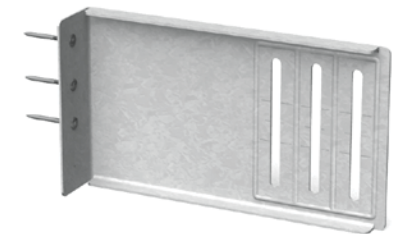
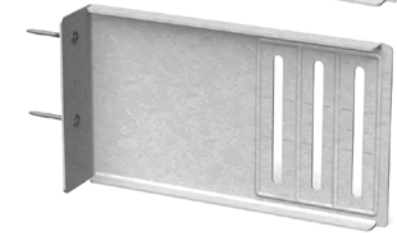

Location Options with (3) Anchors

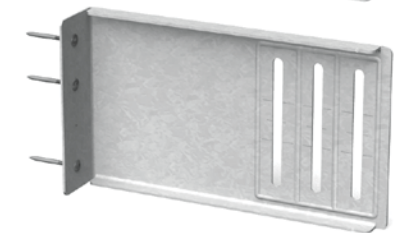

(4) Anchors

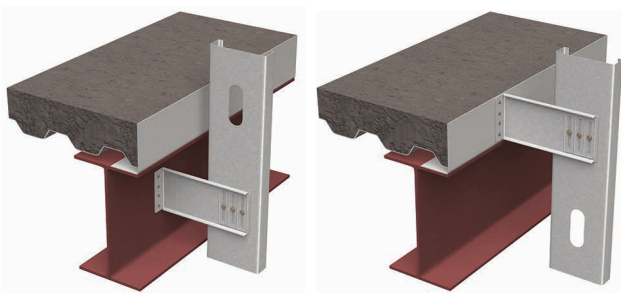

## 8" 97mils Extended FastClip™ Slide Clip

## 12ga Extended FastClip (FCEC) Allowable Loads (lbs)

Anchor Type	Stud Thickness / Yield Strength	No. Anchors to Structure	Allowable Load* (lbs)	Allowable Load <sup>#</sup> (lbs)
Weld (Fillet/ Flare Groove) E60XX	33mils (20ga) 33ksi	(3) 1" x 1/16"	608	608
	43mils (18ga) 33ksi	(3) 1" x 1/16"	905	905
	54mils (16ga) 50ksi	(3) 1" x 1/16"	1838	1838
	68mils (14ga) 50ksi	(3) 1" x 1/16"	2180	2180
	97mils (12ga) 50ksi	(3) 1" x 1/16"	2587	2587
Buildex #12-24 Self-Drilling Screws to 3/16" Steel	33mils (20ga) 33ksi	2	608	608
		3	608	608
		4	608	608
	43mils (18ga) 33ksi	2	905	905
		3	905	905
		4	905	905
	54mils (16ga) 50ksi	2	1004	1004
		3	1261	1506
		4	1261	1838
	68mils (14ga) 50ksi	2	1004	1004
		3	1261	1506
		4	1261	2008
	97mils (12ga) 50ksi	2	1004	1004
		3	1261	1506
		4	1261	2008
Hilti 0.157" X-U Powder-Actuated Fasteners (PAF) to 3/16" Steel	33mils (20ga) 33ksi	2	608	608
		3	608	608
		4	608	608
	43mils (18ga) 33ksi	2	905	905
		3	905	905
		4	905	905
	54mils (16ga) 50ksi	2	1064	1064
		3	1261	1596
		4	1261	1838
	68mils (14ga) 50ksi	2	1064	1064
		3	1261	1596
		4	1261	2129
	97mils (12ga) 50ksi	2	1064	1064
		3	1261	1596
		4	1261	2129
Generic Fasteners to 3/16" Steel	33mils (20ga) 33ksi	n	608	608
	43mils (18ga) 33ksi	n	905	905
	54mils (16ga) 50ksi	n	1261	1835
	68mils (14ga) 50ksi	n	1261	2180
	97mils (12ga) 50ksi	n	1261	2587
Ultimate Clip Capacity	33mils (20ga) 33ksi	—	—	1825
	43mils (18ga) 33ksi	—	—	2715
	54mils (16ga) 50ksi	—	—	5514
	68mils (14ga) 50ksi	—	—	6541
	97mils (12ga) 50ksi	—	—	7762

**Notes:**

- 1 Tabulated allowable loads do not include a 1/3 stress increase for wind.
- 2 \* - Allowable capacity includes 1/8" service load limit.
- 3 # - Allowable capacity does not include 1/8" service load limit.
- 4 Allowable weld capacities were calculated by assuming 3 x 1" long welds at the ends and center of the clip bend.
- 5 Listed weld capacities were calculated assuming an E60XX electrode.
- 6 Mechanical fasteners should be attached to the structure in accordance with the manufacturer's instructions. All fasteners were assumed to be installed at a distance of 3/4" from the bend of the structural leg.
- 7 Generic fastener capacities were calculated by considering clip-stud interaction, behavior of clip in tension and compression only. The design professional has to detail for clip and desired fastener installation.
- 8 n - Number of generic mechanical fasteners required for connection to be determined by a design professional. Capacity should not exceed tabulated allowable loads.
- 9 Ultimate clip capacities were tabulated for the purpose of blast loads and they do not assume a safety factor.
- 10 Ultimate clip capacities were calculated by assuming 3 x 1" long weld at the structural leg of the clip (clip bend) welded to 3/16" steel.
- 11 It is the responsibility of the design professional to detail the project drawings for proper clip and fastener installation.
- 12 Buildex is a registered trademark of Illinois Tool Works, Inc.
- 13 Hilti is a registered trademark of Hilti Aktiengesellschaft Corporation.

**FastClip™ Slide Clip w/Anchor Holes**

**Curtain Wall/Bypass Connected to Slab w/Anchor Bolt**

Vertical building movement up to 3".

ClarkDietrich FCSC-HD 68mils (14ga) is used to attach exterior curtain-wall studs to the building concrete structure and provide for vertical building movement independent of the cold-formed steel framing. Proprietary Deflection Screws are provided with each clip for attachment to the wall studs and allow for 3" vertical deflection (1-1/2" up and down) to ensure friction-free sliding. A 5/8" hole in the short leg of the clip allows for a 1/2" concrete anchor to be attached to the slab. (2) 3/8" holes allow 1/4" anchors.

**MATERIAL SPECIFICATIONS**

- Gauge:** 14 gauge (68mils)
- Design Thickness:** 0.0713 inches
- Yield Strength:** 50ksi
- Coating:** G90
- ASTM:** A653/A1003

**PRODUCT DIMENSIONS**

FCSC-HD: 1-1/2" x 4-1/4" x 6" long

**INSTALLATION**

To attach the clip to the cold-formed steel framing stud, three Proprietary Deflection Screws, shall be driven through the slotted holes and positioned to allow for the appropriate building deflection.

Attachment to the structure concrete slab can be made with 1/2" bolt anchors. Anchor connection design and edge distance requirements must be approved by a design professional before installation.

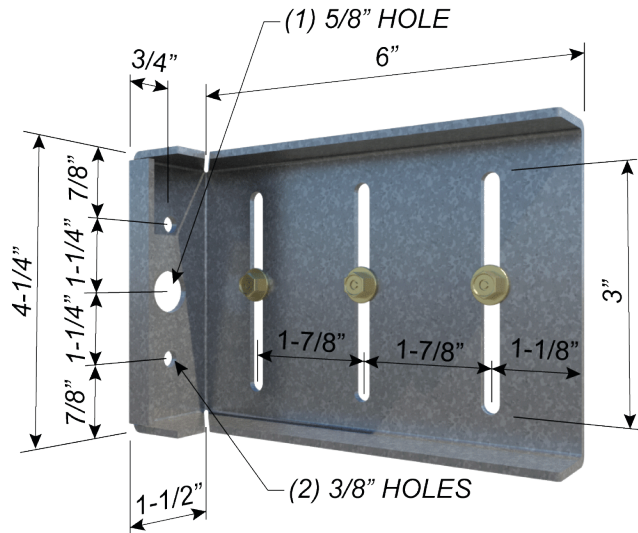

**FCSC-HD Clips**

Product Code	Product Thickness		Size (in)	Packaging Pcs./Bucket
	Mils (Gauge)	Design Thickness (in)		
FCSC-HD	68mils (14ga)	0.0713	1-1/2 x 6 x 4-1/4	25

Includes (80) Proprietary Deflection Screws per carton.



Proprietary Deflection Screw



## FastClip™ Slide Clip w/Anchor Holes (FCSC-HD)

Product Code	Stud Thickness	Yield Strength	Anchors to Structure	ASD Allowable Loads (lbs)		
	(Mils) Gauge			F1	F2 w/ (2) screws into stud	F2 w/ (3) screws into stud
FCSC-HD 68mils (14ga)	33mils (20ga)	33ksi	(1) 1/2" x 2" Hilti KWIK Bolt <sup>3</sup>	50	433	650
	43mils (18ga)	33ksi		95	592	887
	54mils (16ga)	50ksi		152	1054	1054
	68mils (14ga)	50ksi		188	1107	1107
	97mils (12ga)	50ksi		188	1107	1107

### Notes:

- 1 Capacities listed in the table represent the capacity of the clip and the screws to the stud. Capacities listed in notes 3 are limits if the specified connector to the structure is used.
- 2 Capacities listed in the table/notes assume that no load reduction are required for spacing or edge distance of anchors.
- 3 Tension capacity is limited to 1069-lbs when using 1/2" x 2" Hilti KWIK Bolt TZ anchor into 3000psi cracked concrete.
- 4 Other anchors may be used to achieve the full clip capacity but must be designed separately.
- 5 Allowable loads have not been increased for wind, seismic, or other factors.
- 6 Hilti is a registered trademark of Hilti Aktiengesellschaft Corporation.
- 7 It is the responsibility of the designer to properly detail connections on the contract drawings.

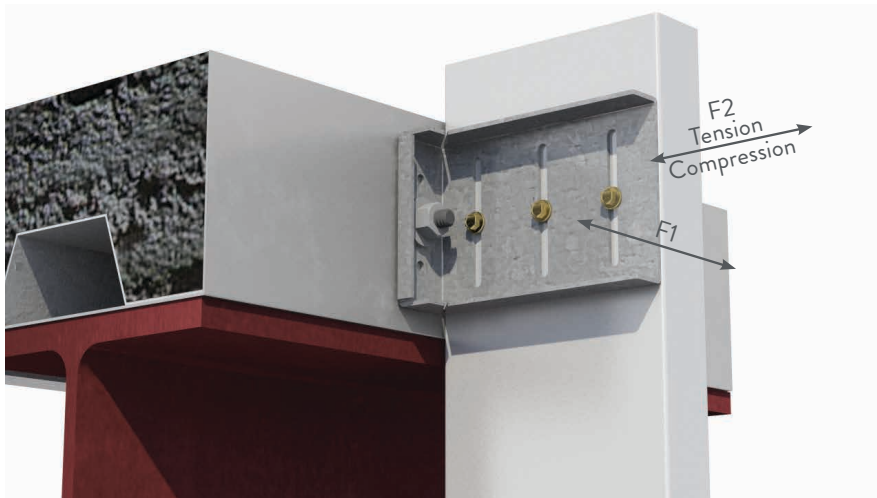

## Universal Bypass Clip

Provides either a rigid connection or vertical building movement up to 3"

Universal Bypass Clips are used to attach exterior curtain wall studs to the building structure and provide either a rigid connection or deflecting connection for vertical building movement independent of the cold-formed steel framing.

The clips are available in standard lengths of 6", 8", 10" and 12" and are ideal for medium to larger standoff conditions. Universal Bypass Clips install quickly with screws, welds or powder-actuated fasteners, and provide adjustable standoff to ensure a plumb wall plane. For deflection application, proprietary deflection screws are provided with each clip to ensure friction-free sliding.

- Eliminates shims and scabs.
- Provides vertical movement up to 3" (1-1/2" up and 1-1/2" down) when installed as a deflection application.
- Specially designed to simplify welding installation.
- Fast, one-piece universal installation.  
No left or right handed clips.
- Proprietary Deflection Screws provide frictionless slip connections. One bag (80 screws) included.

### MATERIAL SPECIFICATIONS

**Gauge:** 14 gauge (68mils)

**Design Thickness:** 0.0713 inches

**Gauge:** 12 gauge (97mils)

**Design Thickness:** 0.1017 inches

**Yield Strength:** Structural Grade 50 Type H (ST50H), 50ksi (340 MPa)

**Coating:** G90 (Z275) hot-dipped galvanized coating

**ASTM:** A653, A1003

### ALTERNATIVE PRODUCTS

FastClip™ Slide Clip

Extended FastClip™ Slide Clip

Extended Uni-Clip™

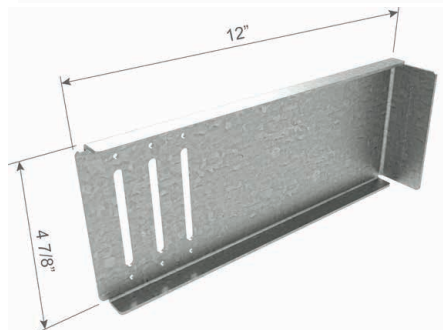
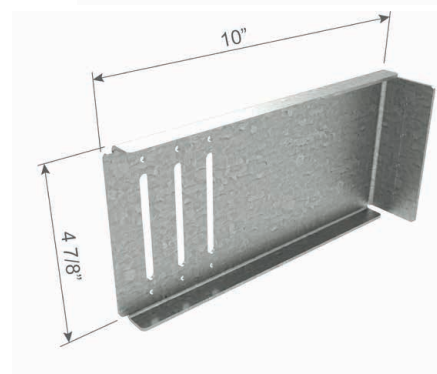
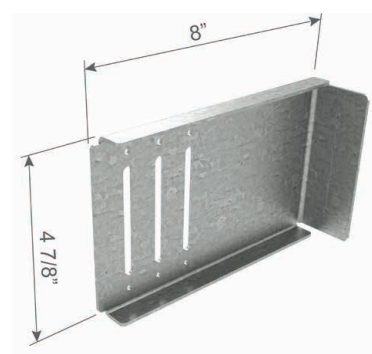
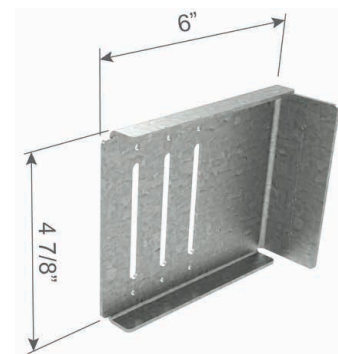

### Universal Bypass Clip (UBC)

Product code	Mils (Gauge)	Design thickness (in)	Size (in)	Pcs/Bucket
UBC6-68	68mils (14ga)	0.0713	1-7/8 x 6 x 4-7/8	25
UBC8-68	68mils (14ga)	0.0713	1-7/8 x 8 x 4-7/8	25
UBC10-68	68mils (14ga)	0.0713	1-7/8 x 10 x 4-7/8	25
UBC12-68	68mils (14ga)	0.0713	1-7/8 x 12 x 4-7/8	25
UBC6-97	97mils (12ga)	0.1017	1-7/8 x 6 x 4-7/8	25
UBC8-97	97mils (12ga)	0.1017	1-7/8 x 8 x 4-7/8	25
UBC10-97	97mils (12ga)	0.1017	1-7/8 x 10 x 4-7/8	25
UBC12-97	97mils (12ga)	0.1017	1-7/8 x 12 x 4-7/8	25

## INSTALLATION

Connections to the building can be made with screws, welds powder-actuated fasteners. Mechanical fasteners shall be located on the embossed marks given on the scored line of the 1-7/8" flange. Attach building anchors to the structure according to the manufacture's instructions. Anchors shall be installed through the embossments on the scored line of the clip as shown on the attached drawings. In no case shall anchors be installed more than 3/4" from the bend on the short leg of the clip. In cases of discrepancy between this information and the Design Engineer's details, the Design Engineer's details shall be followed.

### For a Rigid Connection:

Attach the Universal Bypass Clip to cold-formed steel framing members using (6) #10-16 minimum self-drilling screws (not included) for the 14ga clip and (6) #12-14 minimum self-drilling screws (not included) for the 12ga clip, through the clip holes into the steel framing.

### For a Deflection Connection:

Attach the Universal Bypass Clip to the cold-formed steel framing using (3) #14 Proprietary Deflection Screws (included) through the (3) slotted holes and positioned to allow for the appropriate building deflection.

### Proprietary Deflection Screws:

Many of the ClarkDietrich deflection clips include our proprietary deflection fastener that has been specifically designed to provide friction-free deflection. These fasteners eliminate drag, binding or resistance that can often occur with common fasteners.

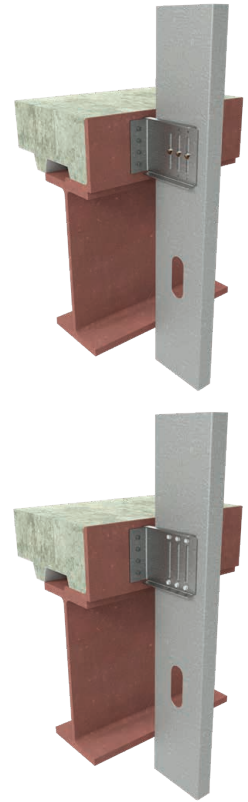

## Universal Bypass Clip

### UBC - 14ga (As a Deflection Connection)

ATTACHMENT TO STRUCTURAL: **DESIGNED BY OTHERS**

Product Code	Stud Thickness / Yield Strength	ASD Allowable Loads (lbs)		
		F1 (In-Plane) w/ (3) #14	F2 (Tension) w/ (3) #14	F3 (Compression) w/ (3) #14
UBC6-68 68mils (14ga)	33mils (20ga) 33ksi	110	605	605
	43mils (18ga) 33ksi	140	905	905
	54mils (16ga) 50ksi	255	1280	1430
	68mils (14ga) 50ksi	255	1280	1430
	97mils (12ga) 50ksi	255	1280	1430
UBC8-68 68mils (14ga)	33mils (20ga) 33ksi	110	605	605
	43mils (18ga) 33ksi	140	905	905
	54mils (16ga) 50ksi	190	1235	1340
	68mils (14ga) 50ksi	190	1235	1340
	97mils (12ga) 50ksi	190	1235	1340
UBC10-68 68mils (14ga)	33mils (20ga) 33ksi	110	605	605
	43mils (18ga) 33ksi	140	905	905
	54mils (16ga) 50ksi	150	1185	1325
	68mils (14ga) 50ksi	150	1185	1325
	97mils (12ga) 50ksi	150	1185	1325
UBC12-68 68mils (14ga)	33mils (20ga) 33ksi	90	605	605
	43mils (18ga) 33ksi	90	905	905
	54mils (16ga) 50ksi	90	1190	1300
	68mils (14ga) 50ksi	90	1190	1300
	97mils (12ga) 50ksi	90	1190	1300

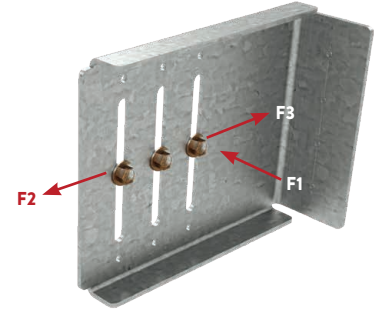

**Notes:**

- 1 Allowable loads (ASD) listed represent the capacity of the clip to the stud only (framing connection).
- 2 Allowable Loads have not been increased for the wind, seismic, or other factors.
- 3 An 1/8-in service deflection load limit was applied to clips resisting F2 and F3 loads. In accordance with ICC AC 261, service deflection limit was not applied to clips resisting F1 loads.
- 4 For Deflection connection, one #14 shouldered screw (Deflection Screw) shall be installed per slot, placed at the center. #14 Deflection Screws are provided with each Universal Bypass Clip.
- 5 Listed capacities are based on the maximum screw pattern. For maximum screw pattern, fill #14 Deflection screws in each slot for a Deflection Clip.
- 6 It is the responsibility of the design professional to design the attachment of the clips to the structure and verify that their capacity meets the requirements of the intended application.
- 7 Nominal or LRFD loads are available upon request.

### UBC - 14ga (As a Deflection Connection)

ATTACHMENT TO STRUCTURAL: **WELDED**

Product Code	Stud Thickness / Yield Strength	ASD Allowable Loads (lbs)		
		F1 (In-Plane) w/ (3) #14	F2 (Tension) w/ (3) #14	F3 (Compression) w/ (3) #14
UBC6-68 68mils (14ga)	33mils (20ga) 33ksi	110	605	605
	43mils (18ga) 33ksi	140	905	905
	54mils (16ga) 50ksi	255	1275	1430
	68mils (14ga) 50ksi	255	1275	1430
	97mils (12ga) 50ksi	255	1275	1430
UBC8-68 68mils (14ga)	33mils (20ga) 33ksi	110	605	605
	43mils (18ga) 33ksi	140	905	905
	54mils (16ga) 50ksi	190	1275	1340
	68mils (14ga) 50ksi	190	1275	1340
	97mils (12ga) 50ksi	190	1275	1340
UBC10-68 68mils (14ga)	33mils (20ga) 33ksi	110	605	605
	43mils (18ga) 33ksi	140	905	905
	54mils (16ga) 50ksi	150	1275	1325
	68mils (14ga) 50ksi	150	1275	1325
	97mils (12ga) 50ksi	150	1275	1325
UBC12-68 68mils (14ga)	33mils (20ga) 33ksi	90	605	605
	43mils (18ga) 33ksi	90	905	905
	54mils (16ga) 50ksi	90	1275	1300
	68mils (14ga) 50ksi	90	1275	1300
	97mils (12ga) 50ksi	90	1275	1300

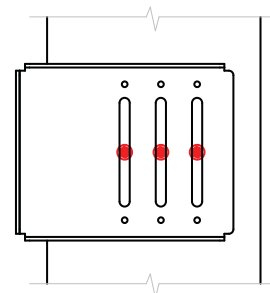
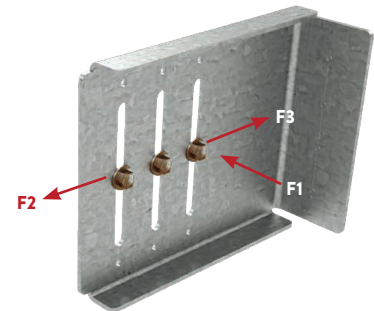

(3) #14 Deflection Screw Pattern  
Shown in a UBC6 Clip

**Notes:**

- 1 Allowable Loads (ASD) have not been increased for the wind, seismic, or other factors.
- 2 For Deflection clip, one #14 shouldered screw (UBC Deflection Screw) shall be installed per slot, placed at the center. Clip gauge-specific #14 UBC Deflection Screws are provided with each Universal Bypass Clip.
- 3 Listed capacities are based on the maximum screw pattern. For maximum screw pattern, fill #14 Deflection screws in each slot for a Deflection Clip.
- 4 The Allowable loads listed for welds are based on the following weld lengths:
  - (2) Welds - 1" along back of short leg clip bend (each weld equally distanced from center of clip)
- 5 Use E70XX (min.) electrodes.
- 6 It is the responsibility of the design professional to verify that the connection design meets the requirements of the intended application.
- 7 Nominal or LRFD loads are available upon request.

**UBC - 14ga (As a Deflection Connection)**

**ATTACHMENT TO STRUCTURAL: (4) #12-24 FASTENERS**

Product Code	Stud Thickness / Yield Strength	ASD Allowable Loads (lbs)		
		F1 (In-Plane) w/ (3) #14	F2 (Tension) w/ (3) #14	F3 (Compression) w/ (3) #14
UBC6-68 68mils (14ga)	33mils (20ga) 33ksi	110	605	605
	43mils (18ga) 33ksi	140	905	905
	54mils (16ga) 50ksi	255	1280	1430
	68mils (14ga) 50ksi	255	1280	1430
	97mils (12ga) 50ksi	255	1280	1430
UBC8-68 68mils (14ga)	33mils (20ga) 33ksi	110	605	605
	43mils (18ga) 33ksi	140	905	905
	54mils (16ga) 50ksi	190	1235	1340
	68mils (14ga) 50ksi	190	1235	1340
	97mils (12ga) 50ksi	190	1235	1340
UBC10-68 68mils (14ga)	33mils (20ga) 33ksi	110	605	605
	43mils (18ga) 33ksi	140	905	905
	54mils (16ga) 50ksi	150	1185	1325
	68mils (14ga) 50ksi	150	1185	1325
	97mils (12ga) 50ksi	150	1185	1325
UBC12-68 68mils (14ga)	33mils (20ga) 33ksi	90	605	605
	43mils (18ga) 33ksi	90	905	905
	54mils (16ga) 50ksi	90	1190	1300
	68mils (14ga) 50ksi	90	1190	1300
	97mils (12ga) 50ksi	90	1190	1300

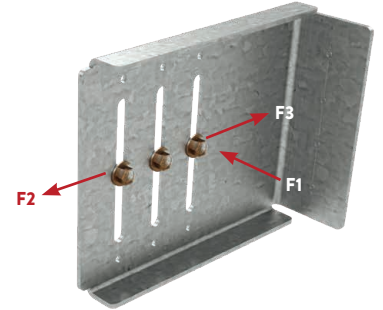

**Notes:**

- 1 Allowable Loads (ASD) have not been increased for the wind, seismic, or other factors.
- 2 An 1/8-in service deflection load limit was applied to clips resisting F2 and F3 loads. In accordance with ICC AC 261, service deflection limit was not applied to clips resisting F1 loads.
- 3 For Deflection clip, one #14 shouldered screw (UBC Deflection Screw) shall be installed per slot, placed at the center. Clip gauge-specific #14 UBC Deflection Screws are provided with each UBC.
- 4 Listed capacities are based on the maximum screw pattern. For maximum screw pattern, fill #14 Deflection screws in each slot for a Deflection Clip.
- 5 #12-24 Fasteners shall be used for attachment to 3/16" steel structure. (4) Fastener configuration shall be used. Screws should be placed at indentations scribed on the short leg of the UBC clip.
- 6 The minimum edge distance for each fastener type shall comply with the fastener manufacturer's recommendation.
- 7 It is the responsibility of the design professional to verify that the connection design meets the requirements of the intended application.
- 8 Nominal or LRFD loads are available upon request.

**UBC - 14ga (As a Deflection Connection)**

**ATTACHMENT TO STRUCTURAL: (4) 0.157" PAFs**

Product Code	Stud Thickness / Yield Strength	ASD Allowable Loads (lbs)		
		F1 (In-Plane) w/ (3) #14	F2 (Tension) w/ (3) #14	F3 (Compression) w/ (3) #14
UBC6-68 68mils (14ga)	33mils (20ga) 33ksi	110	605	605
	43mils (18ga) 33ksi	140	905	905
	54mils (16ga) 50ksi	255	1280	1430
	68mils (14ga) 50ksi	255	1280	1430
	97mils (12ga) 50ksi	255	1280	1430
UBC8-68 68mils (14ga)	33mils (20ga) 33ksi	110	605	605
	43mils (18ga) 33ksi	140	905	905
	54mils (16ga) 50ksi	190	1235	1340
	68mils (14ga) 50ksi	190	1235	1340
	97mils (12ga) 50ksi	190	1235	1340
UBC10-68 68mils (14ga)	33mils (20ga) 33ksi	110	605	605
	43mils (18ga) 33ksi	140	905	905
	54mils (16ga) 50ksi	150	1185	1325
	68mils (14ga) 50ksi	150	1185	1325
	97mils (12ga) 50ksi	150	1185	1325
UBC12-68 68mils (14ga)	33mils (20ga) 33ksi	90	605	605
	43mils (18ga) 33ksi	90	905	905
	54mils (16ga) 50ksi	90	1190	1300
	68mils (14ga) 50ksi	90	1190	1300
	97mils (12ga) 50ksi	90	1190	1300

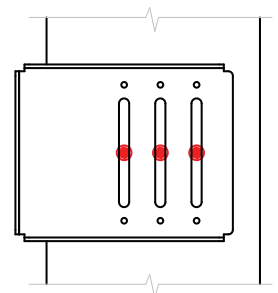
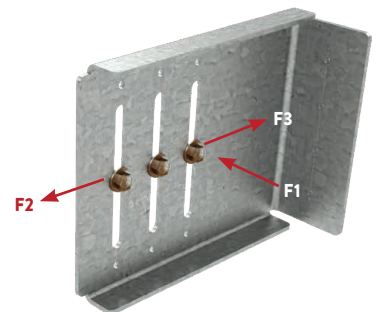

**(3) #14 Deflection Screw Pattern  
Shown in a UBC6 Clip**

**Notes:**

- 1 Allowable Loads (ASD) have not been increased for the wind, seismic, or other factors.
- 2 Capacities considered for Hilti PAFs are based on fastener strengths listed in ICC ESR-2269.
- 3 It is the responsibility of the design professional to verify that the connection design meets the requirements of the intended application.
- 4 Listed capacities are based on the maximum screw pattern. For maximum screw pattern, fill #14 Deflection screws in each slot for a Deflection Clip.
- 5 Nominal or LRFD loads are available upon request.
- 6 An 1/8-in service deflection load limit was applied to clips resisting F2 and F3 loads. In accordance with ICC AC 261, service deflection limit was not applied to clips resisting F1 loads.
- 7 For Deflection clip, one #14 shouldered screw (UBC Deflection Screw) shall be installed per slot, placed at the center. Clip gauge-specific #14 UBC Deflection Screws are provided with each UBC.
- 8 0.157" Hilti X-U PAFs shall be used for attachment to 3/16" steel structure. (4) Fastener configuration shall be used. PAFs should be placed at indentations scribed on the short leg of the UBC clip.

## Universal Bypass Clip

### UBC - 12ga (As a Deflection Connection)

ATTACHMENT TO STRUCTURAL: **DESIGNED BY OTHERS**

Product Code	Stud Thickness / Yield Strength	ASD Allowable Loads (lbs)		
		F1 (In-Plane) w/ (3) #14	F2 (Tension) w/ (3) #14	F3 (Compression) w/ (3) #14
UBC6-97 97mils (12ga)	33mils (20ga) 33ksi	110	605	605
	43mils (18ga) 33ksi	140	905	905
	54mils (16ga) 50ksi	260	1535	1680
	68mils (14ga) 50ksi	280	1535	1680
	97mils (12ga) 50ksi	280	1535	1680
UBC8-97 97mils (12ga)	33mils (20ga) 33ksi	110	605	605
	43mils (18ga) 33ksi	140	905	905
	54mils (16ga) 50ksi	225	1525	1685
	68mils (14ga) 50ksi	225	1525	1685
	97mils (12ga) 50ksi	225	1525	1685
UBC10-97 97mils (12ga)	33mils (20ga) 33ksi	110	605	605
	43mils (18ga) 33ksi	140	905	905
	54mils (16ga) 50ksi	185	1490	1630
	68mils (14ga) 50ksi	185	1490	1630
	97mils (12ga) 50ksi	185	1490	1630
UBC12-97 97mils (12ga)	33mils (20ga) 33ksi	90	605	605
	43mils (18ga) 33ksi	90	905	905
	54mils (16ga) 50ksi	90	1490	1630
	68mils (14ga) 50ksi	90	1490	1630
	97mils (12ga) 50ksi	90	1490	1630

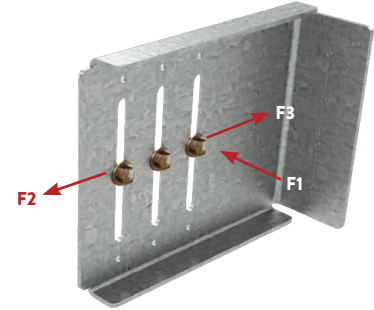

- Notes:**
- 1 Allowable loads (ASD) listed represent the capacity of the clip to the stud only. (Framing connection).
  - 2 Allowable Loads have not been increased for the wind, seismic, or other factors.
  - 3 An 1/8-in service deflection load limit was applied to clips resisting F2 and F3 loads. In accordance with ICC AC 261, service deflection limit was not applied to clips resisting F1 loads.
  - 4 For Deflection connection, one #14 shouldered screw (Deflection Screw) shall be installed per slot, placed at the center. #14 Deflection Screws are provided with each Universal Bypass Clip.
  - 5 Listed capacities are based on the maximum screw pattern. For maximum screw pattern, fill #14 Deflection screws in each slot for a Deflection Clip.
  - 6 It is the responsibility of the design professional to design the attachment of the clips to the structure and verify that their capacity meets the requirements of the intended application.
  - 7 Nominal or LRFD loads are available upon request.

### UBC - 12ga (As a Deflection Connection)

ATTACHMENT TO STRUCTURAL: **WELDED**

Product Code	Stud Thickness / Yield Strength	ASD Allowable Loads (lbs)		
		F1 (In-Plane) w/ (3) #14	F2 (Tension) w/ (3) #14	F3 (Compression) w/ (3) #14
UBC6-97 97mils (12ga)	33mils (20ga) 33ksi	110	605	605
	43mils (18ga) 33ksi	140	905	905
	54mils (16ga) 50ksi	260	1535	1680
	68mils (14ga) 50ksi	280	1535	1680
	97mils (12ga) 50ksi	280	1535	1680
UBC8-97 97mils (12ga)	33mils (20ga) 33ksi	110	605	605
	43mils (18ga) 33ksi	140	905	905
	54mils (16ga) 50ksi	225	1535	1685
	68mils (14ga) 50ksi	225	1535	1685
	97mils (12ga) 50ksi	225	1535	1685
UBC10-97 97mils (12ga)	33mils (20ga) 33ksi	110	605	605
	43mils (18ga) 33ksi	140	905	905
	54mils (16ga) 50ksi	185	1535	1630
	68mils (14ga) 50ksi	185	1535	1630
	97mils (12ga) 50ksi	185	1535	1630
UBC12-97 97mils (12ga)	33mils (20ga) 33ksi	90	605	605
	43mils (18ga) 33ksi	90	905	905
	54mils (16ga) 50ksi	90	1535	1630
	68mils (14ga) 50ksi	90	1535	1630
	97mils (12ga) 50ksi	90	1535	1630

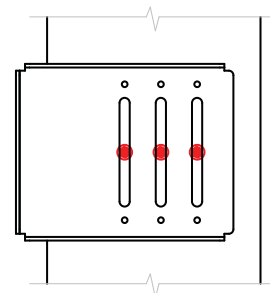
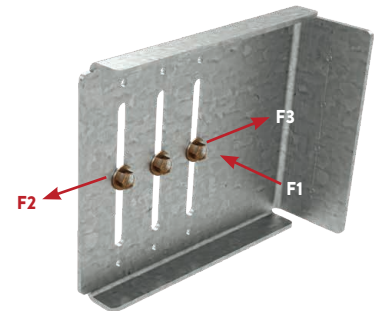

(3) #14 Deflection Screw Pattern  
Shown in a UBC6 Clip

- Notes:**
- 1 Allowable Loads (ASD) have not been increased for the wind, seismic, or other factors.
  - 2 For Deflection clip, one #14 shouldered screw (UBC Deflection Screw) shall be installed per slot, placed at the center. Clip gauge-specific #14 UBC Deflection Screws are provided with each Universal Bypass Clip.
  - 3 Listed capacities are based on the maximum screw pattern. For maximum screw pattern, fill #14 Deflection screws in each slot for a Deflection Clip.
  - 4 The Allowable loads listed for welds are based on the following weld lengths:
    - (2) Welds - 1" along back of short leg clip bend (each weld equally distanced from center of clip)
  - 5 Use E70XX (min.) electrodes.
  - 6 It is the responsibility of the design professional to verify that the connection design meets the requirements of the intended application.
  - 7 Nominal or LRFD loads are available upon request.

**UBC - 12ga (As a Deflection Connection)**

**ATTACHMENT TO STRUCTURAL: (4) #12-24 FASTENERS**

Product Code	Stud Thickness / Yield Strength	ASD Allowable Loads (lbs)		
		F1 (In-Plane) w/ (3) #14	F2 (Tension) w/ (3) #14	F3 (Compression) w/ (3) #14
UBC6-97 97mils (12ga)	33mils (20ga) 33ksi	110	605	605
	43mils (18ga) 33ksi	140	905	905
	54mils (16ga) 50ksi	260	1535	1680
	68mils (14ga) 50ksi	280	1535	1680
	97mils (12ga) 50ksi	280	1535	1680
UBC8-97 97mils (12ga)	33mils (20ga) 33ksi	110	605	605
	43mils (18ga) 33ksi	140	905	905
	54mils (16ga) 50ksi	225	1525	1685
	68mils (14ga) 50ksi	225	1525	1685
	97mils (12ga) 50ksi	225	1525	1685
UBC10-97 97mils (12ga)	33mils (20ga) 33ksi	110	605	605
	43mils (18ga) 33ksi	140	905	905
	54mils (16ga) 50ksi	185	1490	1630
	68mils (14ga) 50ksi	185	1490	1630
	97mils (12ga) 50ksi	185	1490	1630
UBC12-97 97mils (12ga)	33mils (20ga) 33ksi	90	605	605
	43mils (18ga) 33ksi	90	905	905
	54mils (16ga) 50ksi	90	1490	1630
	68mils (14ga) 50ksi	90	1490	1630
	97mils (12ga) 50ksi	90	1490	1630

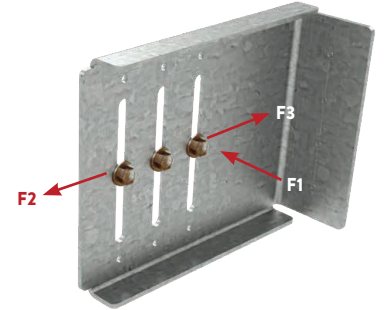

**Notes:**

- 1 Allowable Loads (ASD) have not been increased for the wind, seismic, or other factors.
- 2 An 1/8-in service deflection load limit was applied to clips resisting F2 and F3 loads. In accordance with ICC AC 261, service deflection limit was not applied to clips resisting F1 loads.
- 3 For Deflection clip, one #14 shouldered screw (UBC Deflection Screw) shall be installed per slot, placed at the center. Clip gauge-specific #14 UBC Deflection Screws are provided with each UBC.
- 4 Listed capacities are based on the maximum screw pattern. For maximum screw pattern, fill #14 Deflection screws in each slot for a Deflection Clip.
- 5 #12-24 Fasteners shall be used for attachment to 3/16" steel structure. (4) Fastener configuration shall be used. Screws should be placed at indentations scribed on the short leg of the UBC clip.
- 6 The minimum edge distance for each fastener type shall comply with the fastener manufacturer's recommendation.
- 7 It is the responsibility of the design professional to verify that the connection design meets the requirements of the intended application.
- 8 Nominal or LRFD loads are available upon request.

**UBC - 12ga (As a Deflection Connection)**

**ATTACHMENT TO STRUCTURAL: (4) 0.157" PAFs**

Product Code	Stud Thickness / Yield Strength	ASD Allowable Loads (lbs)		
		F1 (In-Plane) w/ (3) #14	F2 (Tension) w/ (3) #14	F3 (Compression) w/ (3) #14
UBC6-97 97mils (12ga)	33mils (20ga) 33ksi	110	605	605
	43mils (18ga) 33ksi	140	905	905
	54mils (16ga) 50ksi	260	1535	1680
	68mils (14ga) 50ksi	280	1535	1680
	97mils (12ga) 50ksi	280	1535	1680
UBC8-97 97mils (12ga)	33mils (20ga) 33ksi	110	605	605
	43mils (18ga) 33ksi	140	905	905
	54mils (16ga) 50ksi	225	1525	1685
	68mils (14ga) 50ksi	225	1525	1685
	97mils (12ga) 50ksi	225	1525	1685
UBC10-97 97mils (12ga)	33mils (20ga) 33ksi	110	605	605
	43mils (18ga) 33ksi	140	905	905
	54mils (16ga) 50ksi	185	1490	1630
	68mils (14ga) 50ksi	185	1490	1630
	97mils (12ga) 50ksi	185	1490	1630
UBC12-97 97mils (12ga)	33mils (20ga) 33ksi	90	605	605
	43mils (18ga) 33ksi	90	905	905
	54mils (16ga) 50ksi	90	1490	1630
	68mils (14ga) 50ksi	90	1490	1630
	97mils (12ga) 50ksi	90	1490	1630

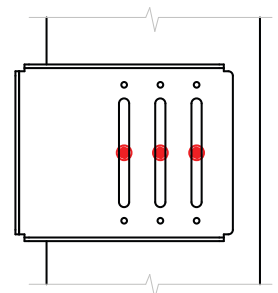
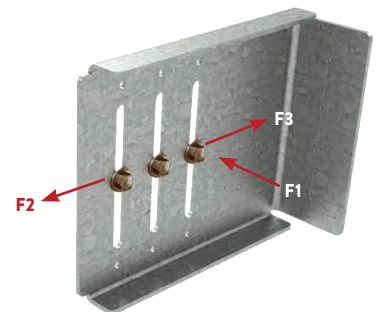

**(3) #14 Deflection Screw Pattern Shown in a UBC6 Clip**

**Notes:**

- 1 Allowable Loads (ASD) have not been increased for the wind, seismic, or other factors.
- 2 Capacities considered for Hilti PAFs are based on fastener strengths listed in ICC ESR-2269.
- 3 It is the responsibility of the design professional to verify that the connection design meets the requirements of the intended application.
- 4 Listed capacities are based on the maximum screw pattern. For maximum screw pattern, fill #14 Deflection screws in each slot for a Deflection Clip.
- 5 Nominal or LRFD loads are available upon request.
- 6 An 1/8-in service deflection load limit was applied to clips resisting F2 and F3 loads. In accordance with ICC AC 261, service deflection limit was not applied to clips resisting F1 loads.
- 7 For Deflection clip, one #14 shouldered screw (UBC Deflection Screw) shall be installed per slot, placed at the center. Clip gauge-specific #14 UBC Deflection Screws are provided with each UBC.
- 8 0.157" Hilti X-U PAFs shall be used for attachment to 3/16" steel structure. (4) Fastener configuration shall be used. PAFs should be placed at indentations scribed on the short leg of the UBC clip.

# Fast Top™ Clip

## Head-of-wall connection

### Head-of-wall deflection conditions for exterior curtain wall and interior, nonload-bearing walls.

ClarkDietrich Fast Top™ Clips are used in head-of-wall deflection conditions for in-fill curtain wall assemblies and/or interior nonload-bearing partitions to provide for vertical movement. These clips are used in place of, or in combination with, deflection track. They also make a positive attachment and eliminate the need to install bridging continuously throughout the upper-most punchouts. The Fast Top clip connectors can be attached to the underside of structural members, concrete decks or floor assemblies. Studs must be cut less than full height to enable vertical movement up to 2-1/2" (1-1/4" up and down). Fast Top clips install quickly with welds, screws or powder-actuated fasteners. Proprietary Deflection Screws are used to attach the clip to the cold-formed framing and to ensure frictionless deflection. These clips are also embossed with fastening patterns to ensure accurate placement of fasteners.

### MATERIAL SPECIFICATIONS

- Gauge:** 14 gauge (68mils)
- Design Thickness:** 0.0713 inches
- Coating:** G90
- Yield Strength:** 50ksi
- ASTM:** A653/A653M

### ALTERNATIVE PRODUCTS

MaxTrak® Slotted Deflection Track

### INSTALLATION

Connections to the building can be made with screws, powder-actuated fasteners, drill-in concrete anchors or welding. Mechanical fasteners shall be equally spaced along the scored line of the 1-1/2" flange. When using the tabulated allowable loads in the tables on the opposite page, connections to the building structure must be made according to the notes. Proprietary Deflection Screws are used to attach the clip to the cold-formed steel framing. Screws shall be driven through the slotted holes and positioned to allow for the appropriate building deflection. Two deflection screws are required with the FTC3, three deflection screws are required with the FTC5, and four deflection screws are required with the FTC8, FTC10, FTC12.

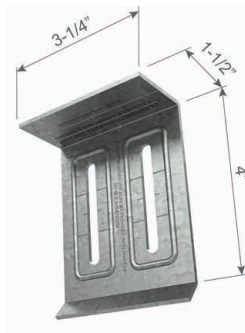

FTC3

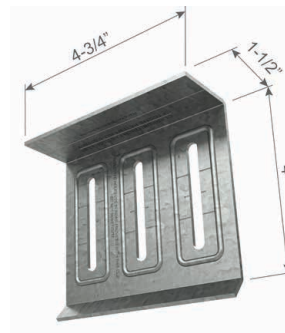

FTC5

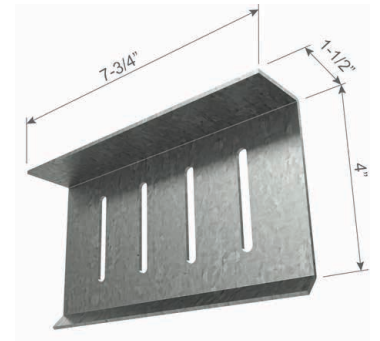

FTC8

### Fast Top™ Clip (FTC)

Product Code	Product Thickness		Size (in)	Packaging Pcs./Bucket
	Mils (Gauge)	Design Thickness (in)		
FTC3	68mils (14ga)	0.0713	1-1/2 x 4 x 3-1/4	25
FTC5	68mils (14ga)	0.0713	1-1/2 x 4 x 4-3/4	30
FTC8	68mils (14ga)	0.0713	1-1/2 x 4 x 7-3/4	25
FTC10	68mils (14ga)	0.0713	1-1/2 x 4 x 9-3/4	25
FTC12	68mils (14ga)	0.0713	1-1/2 x 4 x 11-3/4	25

FTC3 includes 55 Proprietary Deflection Screws per carton.  
 FTC5 includes 110 Proprietary Deflection Screws per carton.  
 FTC8 includes 110 Proprietary Deflection Screws per carton.  
 FTC10 includes 110 Proprietary Deflection Screws per carton.  
 FTC12 includes 110 Proprietary Deflection Screws per carton.

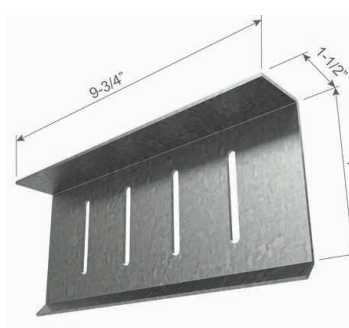

FTC10

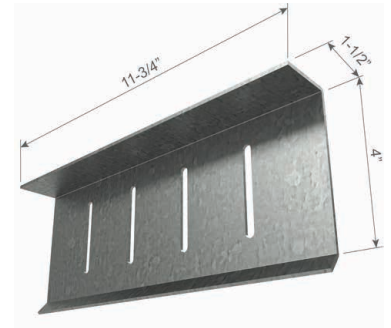

FTC12



Proprietary Deflection Screw



**FTC3 Allowable Loads (lbs)**

Stud Thickness / Yield Strength	Slip Allowance (in)	Welded direct to structural steel	Mechanically Anchored				
			Number of Anchors	PAF in steel (FS=5)	PAF in steel (FS=10)	Buildex #12-24 screws in steel	Hilti 1/4" x 1-3/4" Kwik-Cons in concrete
20ga (33mils) 33ksi	0.75	259	2	259	252	259	241
		259	3	259	259	259	—
	1.25	259	2	259	219	259	206
		259	3	259	241	259	—
18ga (43mils) 33ksi	0.75	471	2	471	252	471	241
		471	3	471	286	471	—
	1.25	471	2	437	219	471	206
		471	3	471	241	471	—
16ga (54mils) 33ksi	0.75	551	2	504	252	551	241
		551	3	551	286	551	—
	1.25	551	2	437	219	551	206
		551	3	477	241	551	—

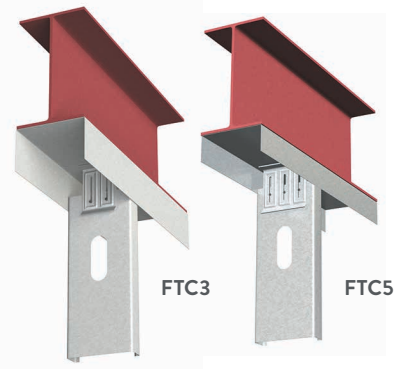

**FTC5 Allowable Loads (lbs)**

Stud Thickness / Yield Strength	Slip Allowance (in)	Welded direct to structural steel	Mechanically Anchored				
			Number of Anchors	PAF in steel (FS=5)	PAF in steel (FS=10)	Buildex #12-24 screws in steel	Hilti 1/4" x 1-3/4" Kwik-Cons in concrete
20ga (33mils) 33ksi	0.75	386	2	386	317	386	386
		386	3	386	386	386	386
		386	4	386	386	386	—
	1.25	386	2	386	286	386	386
		386	3	386	338	386	386
		386	4	386	371	386	—
18ga (43mils) 33ksi	0.75	505	2	505	317	505	469
		505	3	505	389	505	466
		505	4	505	440	505	—
	1.25	505	2	505	286	505	411
		505	3	505	338	505	399
		505	4	505	371	505	—
16ga (54mils) 33ksi	0.75	638	2	634	317	638	469
		638	3	638	389	638	466
		638	4	638	440	638	—
	1.25	638	2	571	286	638	411
		638	3	638	338	638	399
		638	4	638	371	638	—
16ga (54mils) 50ksi	0.75	1061	2	634	317	852	469
		1061	3	779	389	1061	466
		1061	4	879	440	1061	—
	1.25	1061	2	571	286	789	411
		1061	3	676	338	922	399
		1061	4	738	371	922	—

**TYPICAL CONSTRUCTION DETAILS**

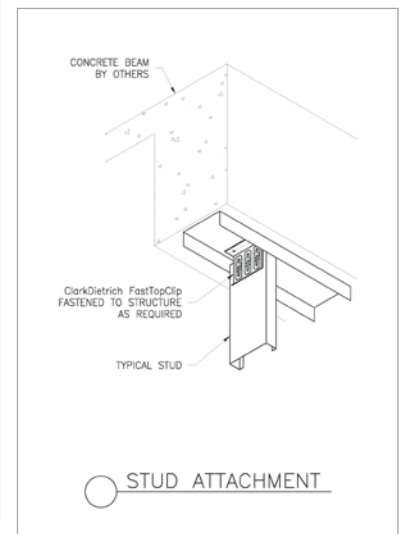

**Notes:**

- For the FTC3, tabulated values for welds are based on 3-1/4" of weld along each edge of the 1-1/2" clip leg.
- For the FTC3, tabulated values for the PAFs and Buildex screws are based on the following: the outermost anchors are placed 1/2" (min.) away from the clip edge and/or bearing edge; anchors are spaced at 2-1/4" (min.) when using two anchors, and 1-1/8" (min.) when using three anchors.
- For the FTC3, tabulated values for Hilti Kwik-Cons are based on the following: anchors are spaced at 2-1/4" o.c. (min.); anchors are placed 3/4" (min.) away from edge of building structure, and 1/2" (min.) away from edge of the Fast Top Clip. The tabulated values are based on 3000psi normal weight concrete.
- For the FTC5, tabulated values for welds are based on 4-1/2" of weld along each edge of the 1-1/2" clip leg.
- For the FTC5, tabulated values for the PAFs and Buildex screws are based on the following: the outermost anchors are placed 1/2" (min.) away from the clip edge and/or bearing edge; anchors are spaced at 3-3/4" (min.) when using two anchors, 1-7/8" (min.) when using three anchors, and 1-1/4" when using four anchors.
- For the FTC5, tabulated values for Hilti Kwik-Cons are based on the following: anchors are spaced at 3-3/4" (min.) when using two anchors, and 1-7/8" (min.) when using three anchors; anchors are placed 3/4" (min.) away from edge of building structure and 1/2" (min.) away from edge of the Fast Top Clip. The tabulated values are based on 3000psi normal weight concrete.
- Capacities listed for PAFs are based on minimum PAF requirements listed in General Note #6 on page 9.
- #12-24 screws shall have ultimate shear and tension capacities equal to or greater than those listed on page 6.
- It is the responsibility of the design professional to detail the project drawings for proper clip attachment.
- Contact ClarkDietrich at 888-437-3244 for technical assistance.
- Hilti is a registered trademark of Hilti Aktiengesellschaft Corporation.
- Buildex is a registered trademark of Illinois Tool Works, Inc.

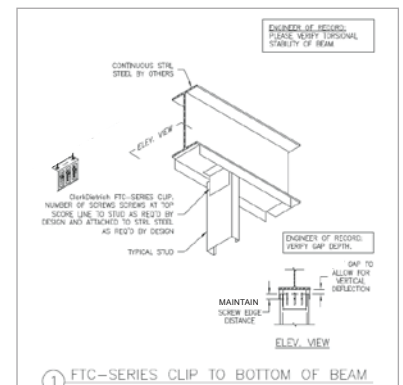

Visit our CAD Library at [cad.clarkdietrich.com](http://cad.clarkdietrich.com) to view or download construction details in .dwg, .dxf, and .pdf formats.

Fast Top™ Clip

Head-of-wall connection

FTC8/FTC10/FTC12 Allowable Loads (lbs)

Stud Thickness / Yield strength	Number of screws to CFS framing	Weld capacity (5-in weld) F2 Load	Mechanically Anchored			
			Number of anchors	(0.157" XU) PAFs (3/16" steel)	(0.145" XU15) PAFs (3/16" steel)	#12-24 screws (3/16" steel)
33mils (20ga) 33ksi	4	450	3	450	320	450
			4	450	410	450
			5	450	450	450
43mils (18ga) 33ksi	4	890	3	850	320	890
			4	890	410	890
			5	890	490	890
54mils (16ga) 50ksi	4	1300	3	850	320	1300
			4	1070	410	1300
			5	1290	490	1300
68mils (14ga) 50ksi	4	1670	3	850	320	1380
			4	1070	410	1670
			5	1290	490	1670
97mils (12ga) 50ksi	4	2230	3	850	320	1380
			4	1070	410	1750
			5	1290	490	2100

Notes:

- 1 Tabulated capacities are for end reaction load directed parallel with the axis of the clip bend, F2 as shown in right image.
- 2 The tabulated values for weld capacities are based on a minimum weld length of 5" centered along the clip bend. E70xx weld assumed to a minimum 3/16" thick A36 structural steel component.
- 3 The tabulated values for #12-24 screws and Hilti PAFs assume a connection centered on a minimum 3/16" thick x 6" wide ASTM A36 structural steel component. These fasteners are to be placed in a single line 3/4" from the 90° bend in the clip.
- 4 Minimum fastener spacing assumed to vary with the number of mechanical fasteners used:
  - a) Three anchors assumed to be spaced 2.5" on-center;
  - b) Four anchors assumed to be spaced 1.67" on-center;
  - c) Five anchors assumed to be spaced 1.25" on-center.
- 5 The minimum edge distance for each fastener type shall comply with the fastener manufacturer's recommendation.
- 6 Capacities listed for #12-24 screws are based on screw strengths listed in CFSEI Tech Note F701-12.
- 7 Capacities listed for Hilti PAFs are based on fastener strengths listed in ICC ESR-2269.
- 8 The FTC shall be connected to the steel framing using ClarkDietrich Proprietary screws (included) installed in all slots of the FTC clip leg; Listed capacities are for the ClarkDietrich Proprietary screws centered in the slotted openings.
- 9 It is the responsibility of the design professional to detail the attachment of the clips and verify that their capacity meets the requirements of the intended application.

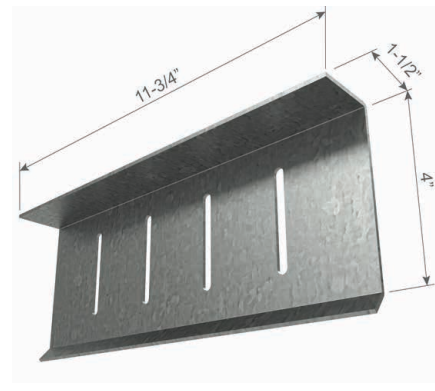
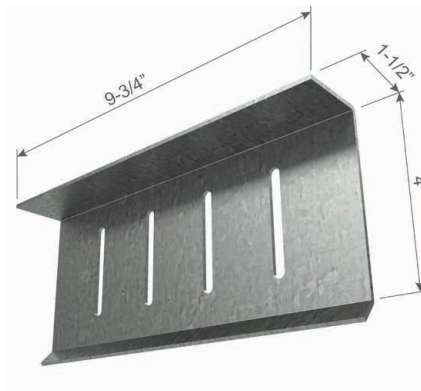
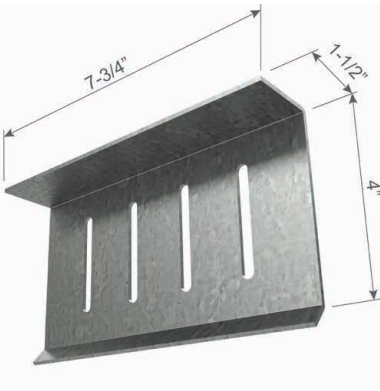
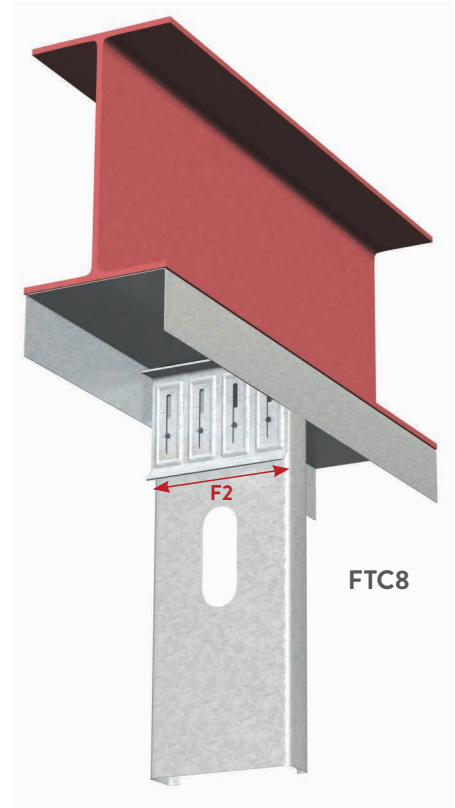

## Flat Tail™ Slide Clip

### Curtain Wall/Bypass

Allows for vertical building movement and provides a horizontal standoff.

ClarkDietrich's Flat Tail™ Slide Clip is used to attach exterior curtain wall studs to the building structure and provide for 2-1/4" vertical building movement independent of the cold-formed steel framing. A Flat Tail Slide Clip provides variable standoff and eliminates the need for shims or additional framing components. The clip easily fastens to the floor/ceiling beam and is secured to the stud with ClarkDietrich Proprietary HD Deflection Screws. The clip restricts lateral movement, but enables vertical movement.

#### INSTALLATION

Connection to the building can be made with screws, powder-actuated fasteners (PAFs), or by welding. Mechanical fasteners shall be located in the pilot holes. (2) Proprietary HD Deflection Screws are required in each slot to attach the clip to the cold-formed steel framing. Screws shall be placed in the slot with 1" center-to-center spacing using guide lines as a reference.

#### CLIP THICKNESS

**Gauge:** 12 gauge (97mils)

**Design Thickness:** 0.1017 inches

**Gauge:** 10 gauge (118mils)

**Design Thickness:** 0.1242 inches

#### MATERIAL SPECIFICATIONS

**Coatings:** G90

**Yield Strength:** 50ksi

**ASTM:** A653/A1003

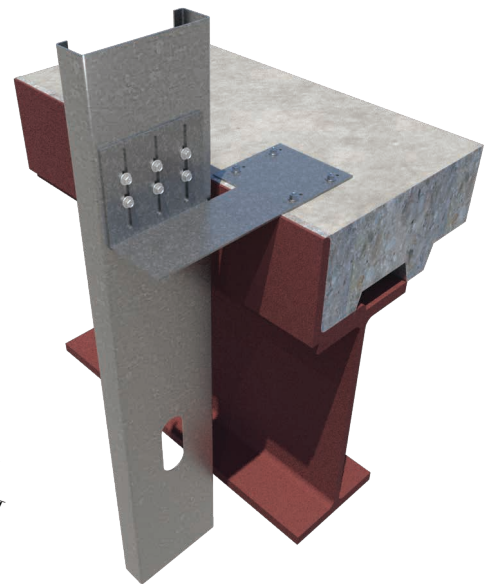
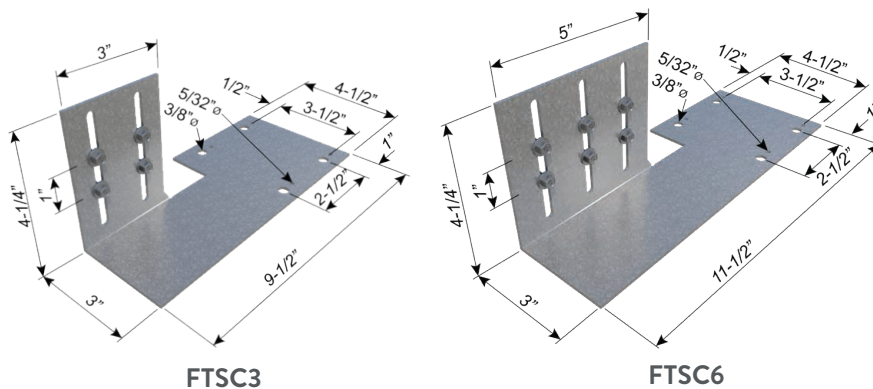

### Flat Tail™ Slide Clip (FTSC)

Product code	Product Thickness		Size (in)	Packaging Pcs./Bucket
	Mils (Gauge)	Design thickness (in)		
FTSC3-97	97mils (12ga)	0.1017	4-1/2" x 9-1/2" x 4-1/4"	25
FTSC3-118	118mils (10ga)	0.1242	4-1/2" x 9-1/2" x 4-1/4"	25

Product code	Product Thickness		Size (in)	Packaging Pcs./Bucket
	Mils (Gauge)	Design thickness (in)		
FTSC6-97	97mils (12ga)	0.1017	4-1/2" x 11-1/2" x 4-1/4"	25
FTSC6-118	118mils (10ga)	0.1242	4-1/2" x 11-1/2" x 4-1/4"	25

#### Notes:

- Clips: 25 clips per bucket.
- Includes 110 Proprietary HD Deflection Screws for FTSC3 per bucket.
- Includes 160 Proprietary HD Deflection Screws for FTSC6 per bucket.

#### PROPRIETARY DEFLECTION SCREWS

Many of the ClarkDietrich deflection clips include our Proprietary Deflection Screw that has been specifically designed to provide friction-free deflection. These fasteners eliminate drag, binding or resistance that can often occur with common fasteners.

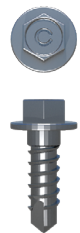

Proprietary HD Deflection Screw (10ga and 12ga Clips Only)

Flat Tail™ Slide Clip

ATTACHMENT TO STRUCTURE: **DESIGNED BY OTHERS**

3-5/8" Flat Tail™ Slide Clip (FTSC3)

Product code	Stud Thickness / Yield Strength	Attachment to Structure	ASD Allowable Loads (lbs)		
			F1 Load	F2 Load	F3 Load
FTSC3-97	33mils (20ga) 33ksi	(2) Fasteners to be designed by others	110	416	388
	43mils (18ga) 33ksi		144	548	397
	54mils (16ga) 50ksi		261	759	596
	68mils (14ga) 50ksi		268	766	673
	97mils (12ga) 50ksi		468	909	699
	33mils (20ga) 33ksi	(4) Fasteners to be designed by others	110	506	428
	43mils (18ga) 33ksi		144	660	397
	54mils (16ga) 50ksi		261	759	596
	68mils (14ga) 50ksi		268	766	673
FTSC3-118	97mils (12ga) 50ksi	(2) Fasteners to be designed by others	468	909	769
	33mils (20ga) 33ksi		110	607	406
	43mils (18ga) 33ksi		144	816	603
	54mils (16ga) 50ksi		261	816	774
	68mils (14ga) 50ksi		328	924	834
	97mils (12ga) 50ksi	(4) Fasteners to be designed by others	468	924	924
	33mils (20ga) 33ksi		110	607	445
	43mils (18ga) 33ksi		144	816	603
	54mils (16ga) 50ksi		261	816	789
	68mils (14ga) 50ksi		328	924	860
	97mils (12ga) 50ksi		468	924	924

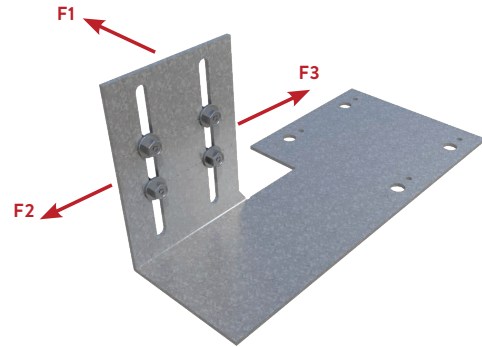

FTSC3

6" Flat Tail™ Slide Clip (FTSC6)

Product code	Stud Thickness / Yield Strength	Attachment to Structure	ASD Allowable Loads (lbs)		
			F1 Load	F2 Load	F3 Load
FTSC6-97	33mils (20ga) 33ksi	(2) Fasteners to be designed by others	165	845	551
	43mils (18ga) 33ksi		216	946	724
	54mils (16ga) 50ksi		316	1057	914
	68mils (14ga) 50ksi		444	1163	962
	97mils (12ga) 50ksi		444	1383	1063
	33mils (20ga) 33ksi	(4) Fasteners to be designed by others	165	869	594
	43mils (18ga) 33ksi		216	959	755
	54mils (16ga) 50ksi		392	1057	930
	68mils (14ga) 50ksi		476	1220	1055
FTSC6-118	97mils (12ga) 50ksi	(2) Fasteners to be designed by others	650	1558	1314
	33mils (20ga) 33ksi		165	861	594
	43mils (18ga) 33ksi		216	1173	874
	54mils (16ga) 50ksi		337	1515	1181
	68mils (14ga) 50ksi		492	1682	1265
	97mils (12ga) 50ksi	(4) Fasteners to be designed by others	492	2026	1439
	33mils (20ga) 33ksi		165	953	594
	43mils (18ga) 33ksi		216	1221	891
	54mils (16ga) 50ksi		392	1515	1215
	68mils (14ga) 50ksi		492	1682	1439
	97mils (12ga) 50ksi		702	2026	1523

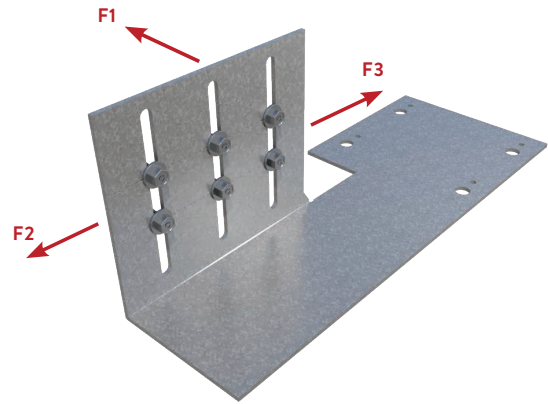

FTSC6

Notes:

- 1 Allowable loads (ASD) listed represent the capacity of the clip to the stud only (framing connection).
- 2 Allowable loads have not been increased for wind, seismic, or other factors.
- 3 (2) #14 Shouldered screws (Proprietary HD Deflection Screws) shall be used per slot, placed with 1-in center-to-center spacing.
  - (4) total screws for the FTSC3 (3-5/8" Clip)
  - (6) total screws for the FTSC6 (6" Clip)
  - #14 Proprietary HD Deflection Screws are provided with each Flat Tail Slide Clip
- 4 It is the responsibility of the design professional to detail the attachment of the clips and verify that their capacity meets the requirements of the intended application.

Flat Tail™ Slide Clip

ATTACHMENT TO STRUCTURE: **WELDED**

3-5/8" Flat Tail™ Slide Clip (FTSC3)

Product code	Stud Thickness / Yield Strength	Attachment to Structure	ASD Allowable Loads (lbs)		
			F1 Load	F2 Load	F3 Load
FTSC3-97	33mils (20ga) 33ksi	(2) Welds - min. 2" length each on either ends	110	506	428
	43mils (18ga) 33ksi		144	660	397
	54mils (16ga) 50ksi		261	759	596
	68mils (14ga) 50ksi		268	766	673
	97mils (12ga) 50ksi		468	909	769
FTSC3-118	33mils (20ga) 33ksi	(2) Welds - min. 2" length each on either ends	110	607	445
	43mils (18ga) 33ksi		144	816	603
	54mils (16ga) 50ksi		261	816	789
	68mils (14ga) 50ksi		328	924	860
	97mils (12ga) 50ksi		468	924	924

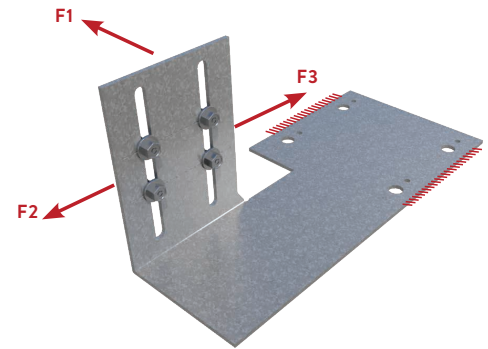

FTSC3

6" Flat Tail™ Slide Clip (FTSC6)

Product code	Stud Thickness / Yield Strength	Attachment to Structure	ASD Allowable Loads (lbs)		
			F1 Load	F2 Load	F3 Load
FTSC6-97	33mils (20ga) 33ksi	(2) Welds - min. 2-3/4" length each on either ends	165	869	594
	43mils (18ga) 33ksi		216	959	755
	54mils (16ga) 50ksi		392	1057	930
	68mils (14ga) 50ksi		476	1220	1055
	97mils (12ga) 50ksi		650	1558	1314
FTSC6-118	33mils (20ga) 33ksi	(2) Welds - min. 2-3/4" length each on either ends	165	953	594
	43mils (18ga) 33ksi		216	1221	891
	54mils (16ga) 50ksi		392	1515	1215
	68mils (14ga) 50ksi		492	1682	1316
	97mils (12ga) 50ksi		702	2026	1523

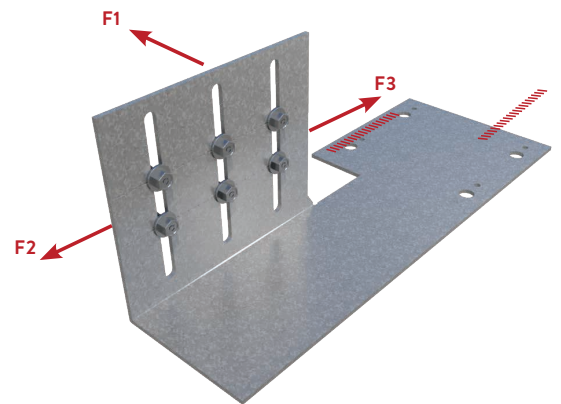

FTSC6

**Notes:**

- 1 Allowable loads have not been increased for wind, seismic, or other factors.
- 2 (2) #14 Shouldered screws (Proprietary HD Deflection Screws) shall be used per slot - placed with 1-in center-to-center spacing.
  - (4) total screws for the FTSC3 (3-5/8" Clip)
  - (6) total screws for the FTSC6 (6" Clip)
  - #14 Proprietary HD Deflection Screws are provided with each Flat Tail Slide Clip
- 3 The tabulated values for welds are based on the following weld lengths:
  - For FTSC3 (3-5/8" Clip) use (2) 2" of weld along parallel edges of the Flat Tail structural attachment leg. (As shown)
  - For FTSC6 (6" Clip) use (2) 2-3/4" of weld along parallel edges of the Flat Tail structural attachment leg. (As shown)
- 4 Use E70XX (min.) electrodes.
- 5 It is the responsibility of the design professional to detail the attachment of the clips and verify that their capacity meets the requirements of the intended application.

Flat Tail™ Slide Clip

ATTACHMENT TO STRUCTURE: 1/4-28 FASTENERS INTO STEEL

3-5/8" Flat Tail™ Slide Clip (FTSC3)

Product code	Stud Thickness / Yield Strength	Attachment to Structure	ASD Allowable Loads (lbs)		
			F1 Load	F2 Load	F3 Load
FTSC3-97	33mils (20ga) 33ksi	(2) 1/4-28 Fasteners to 3/16" Steel	110	416	388
	43mils (18ga) 33ksi		144	548	397
	54mils (16ga) 50ksi		261	759	596
	68mils (14ga) 50ksi		268	766	673
	97mils (12ga) 50ksi		305	847	699
	33mils (20ga) 33ksi	(4) 1/4-28 Fasteners to 3/16" Steel	110	506	428
	43mils (18ga) 33ksi		144	660	397
	54mils (16ga) 50ksi		261	759	596
	68mils (14ga) 50ksi		268	766	673
FTSC3-118	33mils (20ga) 33ksi	(2) 1/4-28 Fasteners to 3/16" Steel	110	607	406
	43mils (18ga) 33ksi		144	816	603
	54mils (16ga) 50ksi		261	816	774
	68mils (14ga) 50ksi		328	924	834
	97mils (12ga) 50ksi		337	924	924
	33mils (20ga) 33ksi	(4) 1/4-28 Fasteners to 3/16" Steel	110	607	445
	43mils (18ga) 33ksi		144	816	603
	54mils (16ga) 50ksi		261	816	789
	68mils (14ga) 50ksi		328	924	860
97mils (12ga) 50ksi	468	924	924		

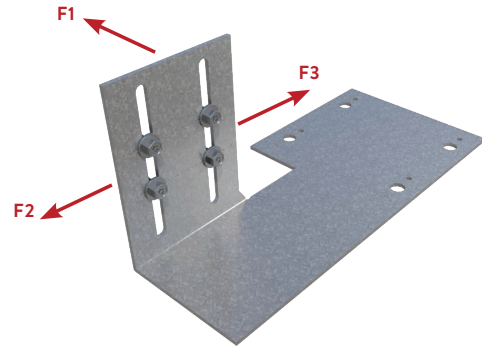

FTSC3

6" Flat Tail™ Slide Clip (FTSC6)

Product code	Stud Thickness / Yield Strength	Attachment to Structure	ASD Allowable Loads (lbs)		
			F1 Load	F2 Load	F3 Load
FTSC6-97	33mils (20ga) 33ksi	(2) 1/4-28 Fasteners to 3/16" Steel	165	845	551
	43mils (18ga) 33ksi		216	847	724
	54mils (16ga) 50ksi		283	847	847
	68mils (14ga) 50ksi		283	847	847
	97mils (12ga) 50ksi		283	847	847
	33mils (20ga) 33ksi	(4) 1/4-28 Fasteners to 3/16" Steel	165	869	594
	43mils (18ga) 33ksi		216	959	755
	54mils (16ga) 50ksi		392	1057	930
	68mils (14ga) 50ksi		476	1220	1055
FTSC6-118	33mils (20ga) 33ksi	(2) 1/4-28 Fasteners to 3/16" Steel	165	861	594
	43mils (18ga) 33ksi		216	931	874
	54mils (16ga) 50ksi		314	931	931
	68mils (14ga) 50ksi		314	931	931
	97mils (12ga) 50ksi		314	931	931
	33mils (20ga) 33ksi	(4) 1/4-28 Fasteners to 3/16" Steel	165	953	594
	43mils (18ga) 33ksi		216	1221	891
	54mils (16ga) 50ksi		392	1375	1215
	68mils (14ga) 50ksi		492	1375	1316
97mils (12ga) 50ksi	702	1375	1375		

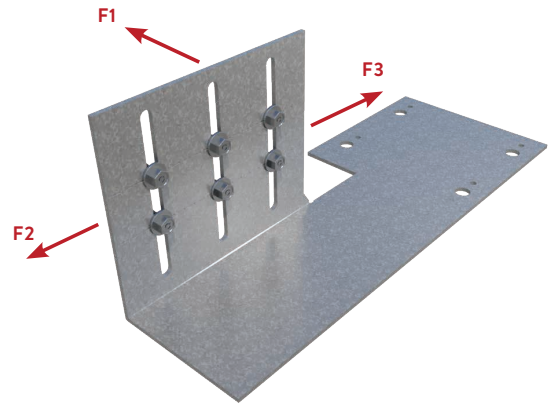

FTSC6

Notes:

- 1 Allowable loads have not been increased for wind, seismic, or other factors.
- 2 (2) #14 Shouldered screws (Proprietary HD Deflection Screws) shall be used per slot - placed with 1-in center-to-center spacing.
  - (4) total screws for the FTSC3 (3-5/8" Clip)
  - (6) total screws for the FTSC6 (6" Clip)
  - #14 Proprietary HD Deflection Screws are provided with each Flat Tail Slide Clip
- 3 1/4-28 Fasteners shall be used for attachment to steel structure. (2) Fastener condition shall be used when a larger offset is required between the structure and the stud. In all other conditions (4) Fastener condition shall be used. Screws to be placed through 5/32" pilot holes in FTSC.
- 4 The minimum edge distance for each fastener type shall comply with the fastener manufacturer's recommendation.
- 5 Capacities listed for 1/4-28 Fasteners are based on screw strengths listed in ICC ESR-1976.
- 6 It is the responsibility of the design professional to detail the attachment of the clips and verify that their capacity meets the requirements of the intended application.

Flat Tail™ Slide Clip

ATTACHMENT TO STRUCTURE: 12-24 FASTENERS INTO STEEL

3-5/8" Flat Tail™ Slide Clip (FTSC3)

Product code	Stud Thickness / Yield Strength	Attachment to Structure	ASD Allowable Loads (lbs)		
			F1 Load	F2 Load	F3 Load
FTSC3-97	33mils (20ga) 33ksi	(2) 12-24 Fasteners to 3/16" Steel	110	416	388
	43mils (18ga) 33ksi		144	548	397
	54mils (16ga) 50ksi		258	716	596
	68mils (14ga) 50ksi		258	716	673
	97mils (12ga) 50ksi		258	716	699
	33mils (20ga) 33ksi	(4) 12-24 Fasteners to 3/16" Steel	110	506	428
	43mils (18ga) 33ksi		144	660	397
	54mils (16ga) 50ksi		261	759	596
	68mils (14ga) 50ksi		268	766	673
FTSC3-118	33mils (20ga) 33ksi	(2) 12-24 Fasteners to 3/16" Steel	110	607	406
	43mils (18ga) 33ksi		144	763	603
	54mils (16ga) 50ksi		261	763	763
	68mils (14ga) 50ksi		276	763	763
	97mils (12ga) 50ksi		276	763	763
	33mils (20ga) 33ksi	(4) 12-24 Fasteners to 3/16" Steel	110	607	445
	43mils (18ga) 33ksi		144	816	603
	54mils (16ga) 50ksi		261	816	789
	68mils (14ga) 50ksi		328	924	860
97mils (12ga) 50ksi	468	924	924		

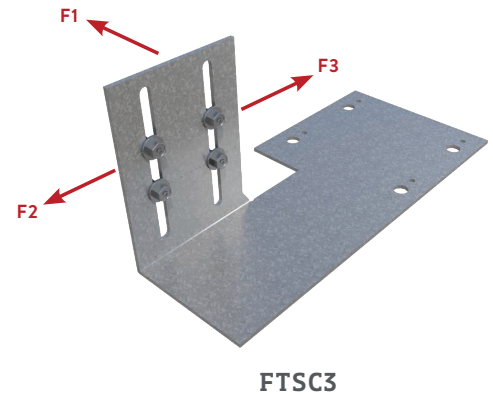

6" Flat Tail™ Slide Clip (FTSC6)

Product code	Stud Thickness / Yield Strength	Attachment to Structure	ASD Allowable Loads (lbs)		
			F1 Load	F2 Load	F3 Load
FTSC6-97	33mils (20ga) 33ksi	(2) 12-24 Fasteners to 3/16" Steel	165	716	551
	43mils (18ga) 33ksi		216	716	716
	54mils (16ga) 50ksi		239	716	716
	68mils (14ga) 50ksi		239	716	716
	97mils (12ga) 50ksi		239	716	716
	33mils (20ga) 33ksi	(4) 12-24 Fasteners to 3/16" Steel	165	869	594
	43mils (18ga) 33ksi		216	959	755
	54mils (16ga) 50ksi		392	1057	930
	68mils (14ga) 50ksi		476	1096	1055
97mils (12ga) 50ksi	541	1096	1096		
FTSC6-118	33mils (20ga) 33ksi	(2) 12-24 Fasteners to 3/16" Steel	165	763	594
	43mils (18ga) 33ksi		216	763	763
	54mils (16ga) 50ksi		256	763	763
	68mils (14ga) 50ksi		256	763	763
	97mils (12ga) 50ksi		256	763	763
	33mils (20ga) 33ksi	(4) 12-24 Fasteners to 3/16" Steel	165	953	594
	43mils (18ga) 33ksi		216	1145	891
	54mils (16ga) 50ksi		392	1145	1145
	68mils (14ga) 50ksi		492	1145	1145
97mils (12ga) 50ksi	576	1145	1145		

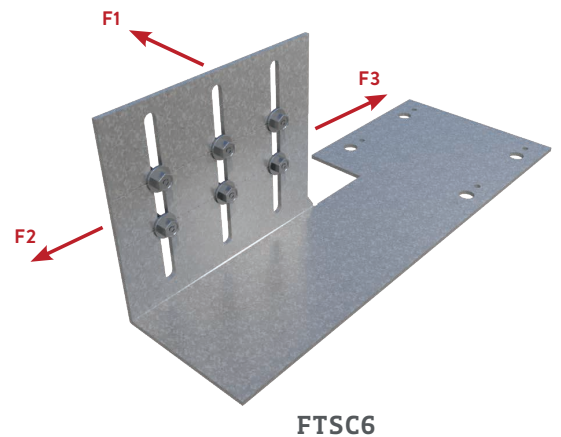

Notes:

- Allowable loads have not been increased for wind, seismic, or other factors.
- (2) #14 Shouldered screws (Proprietary HD Deflection Screws) shall be used per slot - placed with 1-in center-to-center spacing.
  - (4) total screws for the FTSC3 (3-5/8" Clip)
  - (6) total screws for the FTSC6 (6" Clip)
  - #14 Proprietary HD Deflection Screws are provided with each Flat Tail Slide Clip
- #12-24 Fasteners shall be used for attachment to steel structure. (2) Fastener condition shall be used when a larger offset is required between the structure and the stud. In all other conditions (4) Fastener condition shall be used. Screws to be placed through 3/32" pilot holes in FTSC.
- The minimum edge distance for each fastener type shall comply with the fastener manufacturer's recommendation.
- Capacities listed for 12-24 Fasteners are based on screw strengths listed in ICC ESR-1976.
- It is the responsibility of the design professional to detail the attachment of the clips and verify that their capacity meets the requirements of the intended application.

Flat Tail™ Slide Clip

ATTACHMENT TO STRUCTURE: PAF's INTO STEEL

3-5/8" Flat Tail™ Slide Clip (FTSC3)

Product code	Stud Thickness / Yield Strength	Attachment to Structure	ASD Allowable Loads (lbs)		
			F1 Load	F2 Load	F3 Load
FTSC3-97	33mils (20ga) 33ksi	(2) 0.157" PAFs in 3/16" Steel	110	416	388
	43mils (18ga) 33ksi		144	548	397
	54mils (16ga) 50ksi		230	641	596
	68mils (14ga) 50ksi		230	641	641
	97mils (12ga) 50ksi		230	641	641
	33mils (20ga) 33ksi	(4) 0.157" PAFs in 3/16" Steel	110	506	428
	43mils (18ga) 33ksi		144	660	397
	54mils (16ga) 50ksi		261	759	596
	68mils (14ga) 50ksi		268	766	673
FTSC3-118	97mils (12ga) 50ksi	(2) 0.157" PAFs in 3/16" Steel	468	909	769
	33mils (20ga) 33ksi		110	607	406
	43mils (18ga) 33ksi		144	641	603
	54mils (16ga) 50ksi		230	641	641
	68mils (14ga) 50ksi		230	641	641
	97mils (12ga) 50ksi	(4) 0.157" PAFs in 3/16" Steel	230	641	641
	33mils (20ga) 33ksi		110	607	445
	43mils (18ga) 33ksi		144	816	603
	54mils (16ga) 50ksi		261	816	789
	68mils (14ga) 50ksi		328	924	860
97mils (12ga) 50ksi		468	924	924	

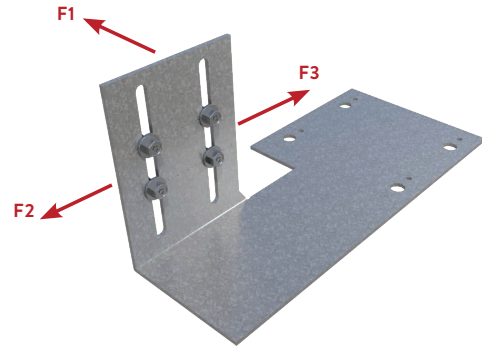

FTSC3

6" Flat Tail™ Slide Clip (FTSC6)

Product code	Stud Thickness / Yield Strength	Attachment to Structure	ASD Allowable Loads (lbs)		
			F1 Load	F2 Load	F3 Load
FTSC6-97	33mils (20ga) 33ksi	(2) 0.157" PAFs in 3/16" Steel	165	641	551
	43mils (18ga) 33ksi		211	641	641
	54mils (16ga) 50ksi		211	641	641
	68mils (14ga) 50ksi		211	641	641
	97mils (12ga) 50ksi		211	641	641
	33mils (20ga) 33ksi	(4) 0.157" PAFs in 3/16" Steel	165	869	594
	43mils (18ga) 33ksi		216	959	755
	54mils (16ga) 50ksi		392	1025	930
	68mils (14ga) 50ksi		476	1025	1025
FTSC6-118	97mils (12ga) 50ksi	(2) 0.157" PAFs in 3/16" Steel	484	1025	1025
	33mils (20ga) 33ksi		165	641	594
	43mils (18ga) 33ksi		211	641	641
	54mils (16ga) 50ksi		211	641	641
	68mils (14ga) 50ksi		211	641	641
	97mils (12ga) 50ksi	(4) 0.157" PAFs in 3/16" Steel	211	641	641
	33mils (20ga) 33ksi		165	953	594
	43mils (18ga) 33ksi		216	1025	891
	54mils (16ga) 50ksi		392	1025	1025
	68mils (14ga) 50ksi		484	1025	1025
97mils (12ga) 50ksi		484	1025	1025	

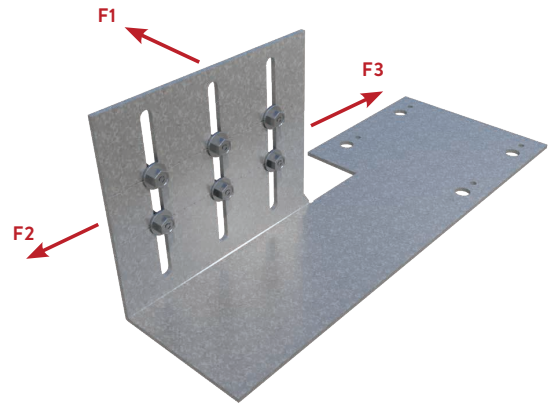

FTSC6

Notes:

- Allowable loads have not been increased for wind, seismic, or other factors.
- (2) #14 Shouldered screws (Proprietary HD Deflection Screws) shall be used per slot - placed with 1-in center-to-center spacing.
  - (4) total screws for the FTSC3 (3-5/8" Clip)
  - (6) total screws for the FTSC6 (6" Clip)
  - #14 Proprietary HD Deflection Screws are provided with each Flat Tail Slide Clip
- 0.157" Hilti XU PAF's shall be used for attachment to steel structure. (2) Fastener condition shall be used when a larger offset is required between the structure and the stud. In all other conditions (4) Fastener condition shall be used. PAF's should be located at cross intersections scribed on the FTSC clip.
- The minimum edge distance for each fastener type shall comply with the fastener manufacturer's recommendation.
- Capacities listed for Hilti PAFs are based on fastener strengths listed in ICC ESR-2269.
- It is the responsibility of the design professional to detail the attachment of the clips and verify that their capacity meets the requirements of the intended application.



Flat Tail™ Slide Clip

ATTACHMENT TO STRUCTURE HILTI KWIK IN CONCRETE

3-5/8" Flat Tail™ Slide Clip (FTSC3)

Product code	Stud Thickness / Yield Strength	Attachment to Structure	ASD Allowable Loads (lbs)		
			F1 Load	F2 Load	F3 Load
FTSC3-97	33mils (20ga) 33ksi	(2) 1/4" Hilti KWIK HUS-EZ (2-1/2" Embedment into 3000 psi uncracked concrete)	110	416	388
	43mils (18ga) 33ksi		144	548	397
	54mils (16ga) 50ksi		261	759	596
	68mils (14ga) 50ksi		268	766	673
	97mils (12ga) 50ksi		303	847	699
FTSC3-118	33mils (20ga) 33ksi	(2) 1/4" Hilti KWIK HUS-EZ (2-1/2" Embedment into 3000 psi uncracked concrete)	110	607	406
	43mils (18ga) 33ksi		144	816	603
	54mils (16ga) 50ksi		261	816	774
	68mils (14ga) 50ksi		303	847	834
	97mils (12ga) 50ksi		303	847	847

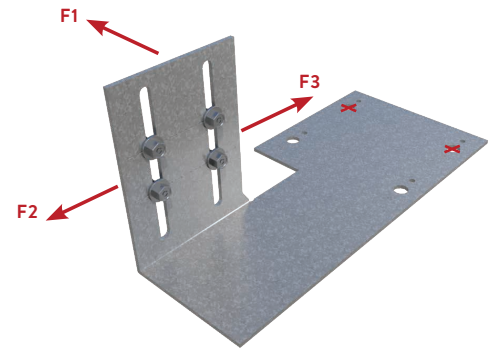

FTSC3

6" Flat Tail™ Slide Clip (FTSC6)

Product code	Stud Thickness / Yield Strength	Attachment to Structure	ASD Allowable Loads (lbs)		
			F1 Load	F2 Load	F3 Load
FTSC6-97	33mils (20ga) 33ksi	(2) 1/4" Hilti KWIK HUS-EZ (2-1/2" Embedment into 3000 psi uncracked concrete)	165	845	551
	43mils (18ga) 33ksi		216	847	724
	54mils (16ga) 50ksi		277	847	847
	68mils (14ga) 50ksi		277	847	847
	97mils (12ga) 50ksi		277	847	847
FTSC6-118	33mils (20ga) 33ksi	(2) 1/4" Hilti KWIK HUS-EZ (2-1/2" Embedment into 3000 psi uncracked concrete)	165	847	594
	43mils (18ga) 33ksi		216	847	847
	54mils (16ga) 50ksi		277	847	847
	68mils (14ga) 50ksi		277	847	847
	97mils (12ga) 50ksi		277	847	847

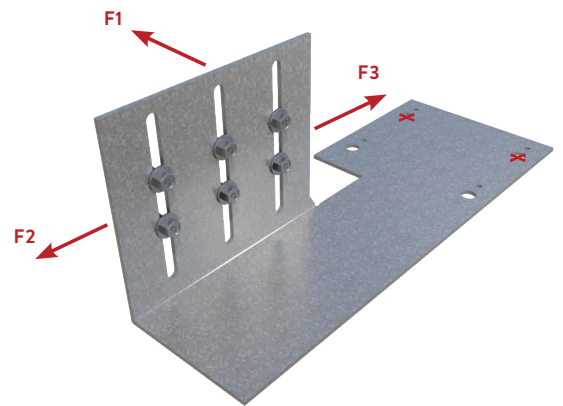

FTSC6

Notes:

- 1 Allowable loads have not been increased for wind, seismic, or other factors.
- 2 (2) #14 Shouldered screws (Proprietary HD Deflection Screws) shall be used per slot - placed with 1-in center-to-center spacing.
  - (4) total screws for the FTSC3 (3-5/8" Clip)
  - (6) total screws for the FTSC6 (6" Clip)
  - #14 Proprietary HD Deflection Screws are provided with each Flat Tail Slide Clip
- 3 1/4" Hilti KWIK HUS-EZ Anchors shall be used for attachment to concrete structure. Anchors shall only be placed in 3/8" diameter holes.
- 4 Capacities listed in the table/notes consider a 3" minimum edge distance for 1/4" Hilti KWIK HUS-EZ anchors embedded 2-1/2" deep into 3000 psi uncracked concrete.
- 5 The load adjustment for 3-1/2" spacing between concrete anchors has been accounted in the tabulated values.
- 6 The minimum concrete thickness (7" thick for 2-1/2" embedment) shall comply with the fastener manufacturer's recommendation.
- 7 It is the responsibility of the design professional to detail the attachment of the clips and verify that their capacity meets the requirements of the intended application.

## Flat Tail™ Slide Clip

### 3-5/8" Flat Tail™ Slide Clip (FTSC3)

Product code	Stud Thickness / Yield Strength	Mechanically Anchored to Structure	ASD Allowable Loads (lbs)					
			Concentric			Eccentric		
			F1 Load	F2 Load	F3 Load	F1 Load	F2 Load	F3 Load
FTSC3-97	97mils (12ga) 50ksi	(2) Fasteners to be designed by others	468	909	699	468	918	647
FTSC3-118	118mils (10ga) 50ksi		468	924	924	468	866	822

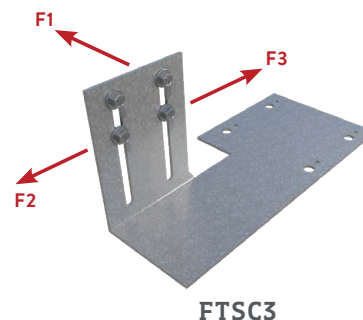

### 3-5/8" Flat Tail™ Slide Clip (FTSC3)

Product code	Stud Thickness / Yield Strength	Mechanically Anchored to Structure	ASD Allowable Loads (lbs)					
			Concentric			Eccentric		
			F1 Load	F2 Load	F3 Load	F1 Load	F2 Load	F3 Load
FTSC3-97	97mils (12ga) 50ksi	(2) 1/4-28 Fasteners in 3/16" steel	305	847	699	251	689	647
FTSC3-118	118mils (10ga) 50ksi		337	924	924	272	744	744

### 3-5/8" Flat Tail™ Slide Clip (FTSC3)

Product code	Stud Thickness / Yield Strength	Mechanically Anchored to Structure	ASD Allowable Loads (lbs)					
			Concentric			Eccentric		
			F1 Load	F2 Load	F3 Load	F1 Load	F2 Load	F3 Load
FTSC3-97	97mils (12ga) 50ksi	(2) 12-24 Fasteners in 3/16" steel	258	716	699	213	585	585
FTSC3-118	118mils (10ga) 50ksi		276	763	763	225	616	616

### 3-5/8" Flat Tail™ Slide Clip (FTSC3)

Product code	Stud Thickness / Yield Strength	Mechanically Anchored to Structure	ASD Allowable Loads (lbs)					
			Concentric			Eccentric		
			F1 Load	F2 Load	F3 Load	F1 Load	F2 Load	F3 Load
FTSC3-97	97mils (12ga) 50ksi	(2) 0.157" PAFs in 3/16" steel	230	641	641	195	538	538
FTSC3-118	118mils (10ga) 50ksi		230	641	641	195	538	538

### 3-5/8" Flat Tail™ Slide Clip (FTSC3)

Product code	Stud Thickness / Yield Strength	Mechanically Anchored to Structure	ASD Allowable Loads (lbs)					
			Concentric			Eccentric		
			F1 Load	F2 Load	F3 Load	F1 Load	F2 Load	F3 Load
FTSC3-97	97mils (12ga) 50ksi	(2) 1/4" Hilti Kwik HUS-EZ 2-1/2" Embedment in to 3000psi uncracked	303	847	699	259	717	647
FTSC3-118	118mils (10ga) 50ksi		303	847	847	259	717	717

**Notes:**

- FTSC3 loads based on (4) Proprietary HD Deflection Screws
- FTSC6 loads based on (6) Proprietary HD Deflection Screws

### 6" Flat Tail™ Slide Clip (FTSC6)

Product code	Stud Thickness / Yield Strength	Mechanically Anchored to Structure	ASD Allowable Loads (lbs)					
			Concentric			Eccentric		
			F1 Load	F2 Load	F3 Load	F1 Load	F2 Load	F3 Load
FTSC6-97	97mils (12ga) 50ksi	(2) Fasteners to be designed by others	444	1383	1063	407	1474	1051
FTSC6-118	118mils (10ga) 50ksi		492	2026	1439	622	1962	1629

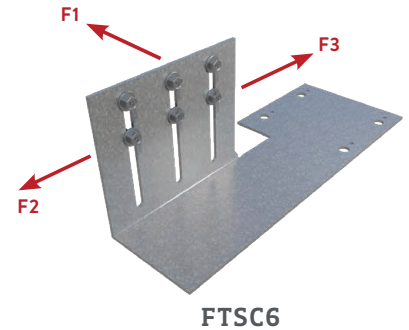

### 6" Flat Tail™ Slide Clip (FTSC6)

Product code	Stud Thickness / Yield Strength	Mechanically Anchored to Structure	ASD Allowable Loads (lbs)					
			Concentric			Eccentric		
			F1 Load	F2 Load	F3 Load	F1 Load	F2 Load	F3 Load
FTSC6-97	97mils (12ga) 50ksi	(2) 1/4-28 Fasteners in 3/16" steel	283	847	847	236	689	689
FTSC6-118	118mils (10ga) 50ksi		314	931	931	257	744	744

### 6" Flat Tail™ Slide Clip (FTSC6)

Product code	Stud Thickness / Yield Strength	Mechanically Anchored to Structure	ASD Allowable Loads (lbs)					
			Concentric			Eccentric		
			F1 Load	F2 Load	F3 Load	F1 Load	F2 Load	F3 Load
FTSC6-97	97mils (12ga) 50ksi	(2) 12-24 Fasteners in 3/16" steel	239	716	716	200	585	585
FTSC6-118	118mils (10ga) 50ksi		256	763	763	212	616	616

### 6" Flat Tail™ Slide Clip (FTSC6)

Product code	Stud Thickness / Yield Strength	Mechanically Anchored to Structure	ASD Allowable Loads (lbs)					
			Concentric			Eccentric		
			F1 Load	F2 Load	F3 Load	F1 Load	F2 Load	F3 Load
FTSC6-97	97mils (12ga) 50ksi	(2) 0.157" PAFs in 3/16" steel	211	641	641	181	538	538
FTSC6-118	118mils (10ga) 50ksi		211	641	641	181	538	538

### 6" Flat Tail™ Slide Clip (FTSC6)

Product code	Stud Thickness / Yield Strength	Mechanically Anchored to Structure	ASD Allowable Loads (lbs)					
			Concentric			Eccentric		
			F1 Load	F2 Load	F3 Load	F1 Load	F2 Load	F3 Load
FTSC6-97	97mils (12ga) 50ksi	(2) 1/4" Hilti Kwik HUS-EZ 2-1/2" Embedment in to 3000psi uncracked	277	847	847	240	717	717
FTSC6-118	118mils (10ga) 50ksi		277	847	847	240	717	717

**Notes:**

- FTSC3 loads based on (4) Proprietary HD Deflection Screws
- FTSC6 loads based on (6) Proprietary HD Deflection Screws

**Fast Strut™**

**Curtain Wall/Bypass**

Commonly used for large standoff conditions.

The ClarkDietrich Fast Strut™ curtain wall connector employs the FastClip™ technology for curtain wall stud attachment and is commonly used when large standoff conditions exist. Fast Strut products are available in standard lengths of 12-1/4" and 15-1/4" and custom lengths of 18", 20", 22" and 24" long to allow framing attachment well beyond the perimeter of the structural steel—or when the spandrel beams are set back from the edge of the structure. Fast Struts are attached to the underside of structural members with screws, welds or powder-actuated fasteners. Studs are plumbed and secured with propriety screws for friction-free deflection. Each clip is also embossed with fastening patterns to ensure accurate placement of fasteners.

**INSTALLATION**

Connections to the building can be made with screws, powder-actuated fasteners, drill-in concrete anchors or welding. Mechanical fasteners shall be equally spaced along the scored line of the 1-1/2" flange. The Fast Strut must engage the building structure a minimum of 4". When using the tabulated allowable loads indicated in the table on the opposite page, connections to the building structure must be made according to the notes. Three Proprietary Deflection Screws are used to attach the Fast Strut to the cold-formed steel framing. Screws shall be driven through the slotted holes and positioned to allow for the appropriate building deflection.

**MATERIAL SPECIFICATIONS**

- Gauge:** 14 gauge (68mils)
- Design Thickness:** 0.0713 inches
- Coating:** G90
- Yield Strength:** 50ksi
- ASTM:** A653/A653M

**PRODUCT DIMENSIONS**

- FS12:** 4" x 1-1/2" x 12-1/4"
- FS15:** 4" x 1-1/2" x 15-1/4"
- Extended Lengths:** 4" x 1-1/2" x 18", 20", 22" and 24"

**ALTERNATIVE PRODUCTS**

FastClip™ Slide Clip

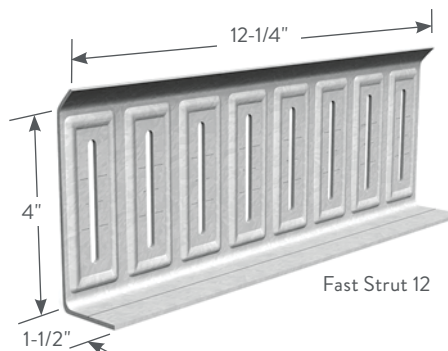

Fast Strut 12

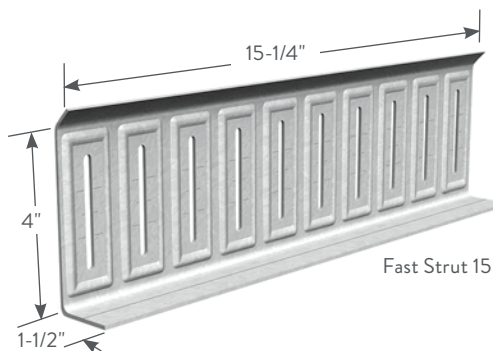

Fast Strut 15

**Fast Strut™ (FS12, FS15, FS18, FS20, FS22, FS24)**

Product code	Thickness		Size (in)	Packaging Pcs./Carton
	Mils (Gauge)	Design thickness (in)		
FS12	68mils (14ga)	0.0713	4 x 1-1/2 x 12-1/4	10
FS15	68mils (14ga)	0.0713	4 x 1-1/2 x 15-1/4	10
FS18	68mils (14ga)	0.0713	4 x 1-1/2 x 18	10
FS20	68mils (14ga)	0.0713	4 x 1-1/2 x 20	10
FS22	68mils (14ga)	0.0713	4 x 1-1/2 x 22	10
FS24	68mils (14ga)	0.0713	4 x 1-1/2 x 24	10
Custom lengths	68mils (14ga)	0.0713	per customer specs	10



Proprietary Deflection Screw

Includes 55 deflection screws per carton.

U.S. Patent No. 6,688,069

**Fast Strut™ FS12, FS15 and FS24 Allowable Loads (lbs)**

Stud thickness	Yield strength	Slip allowance (in)	Welded direct to structural steel	Mechanically Anchored				
				Number of anchors	PAF in steel (FS=5)	PAF in steel (FS=10)	Buildex #12-24 screws in steel	Hilti 1/4"x 1-3/4" Kwik-Cons in concrete
33mils (20ga)	33ksi	0.75	546	2	546	290	546	269
			546	3	546	343	546	—
		1.25	546	2	513	257	546	232
			546	3	546	294	546	—
43mils (18ga)	33ksi	0.75	1522	2	579	290	789	269
			1522	3	686	343	963	—
		1.25	1522	2	513	257	720	232
			1522	3	587	294	760	—
54mils (16ga)	33ksi	0.75	1612	2	579	290	789	269
			1612	3	686	343	963	—
		1.25	1612	2	513	257	720	232
			1612	3	587	294	760	—
54mils (16ga)	50ksi	0.75	1705	2	579	290	789	269
			1705	3	686	343	963	—
		1.25	1705	2	513	257	720	232
			1705	3	587	294	760	—
68mils (14ga)	33ksi	0.75	1792	2	579	290	789	269
			1792	3	686	343	963	—
		1.25	1792	2	513	257	720	232
			1792	3	587	294	760	—
68mils (14ga)	50ksi	0.75	1978	2	579	290	789	269
			1978	3	686	343	963	—
		1.25	1978	2	513	257	720	232
			1978	3	587	294	760	—
97mils (12ga)	33ksi	0.75	2481	2	579	290	789	269
			2481	3	686	343	963	—
		1.25	2481	2	513	257	720	232
			2481	3	587	294	760	—
97mils (12ga)	50ksi	0.75	2997	2	579	290	789	269
			2997	3	686	343	963	—
		1.25	2997	2	513	257	720	232
			2997	3	587	294	760	—

**Notes:**

- 1 Except when welding, tabulated values require a minimum of 4" of structure engagement. For other conditions or technical assistance, contact ClarkDietrich at 888-437-3244.
- 2 The tabulated values for welds are based on the following weld lengths: use 4-1/2" of weld along each edge of the 1-1/2" FastStrut leg for 20, and 18 gauge, use 5-1/2" along each edge for 16 and 14 gauge, use 6-1/2" along each edge for 12 gauge. Use E70XX (min.) electrodes. (Note that the welded values may require more than 4" of structure engagement.)
- 3 Tabulated values for PAFs and Buildex screws are based on the following: fasteners are spaced at 3" o.c. (min.) when using two anchors, and 1-1/2" o.c. (min.) when using three anchors; anchors are placed 1/2" (min.) away from the edge of the building structure, and 1/2" (min.) away from edge of the Fast Strut.
- 4 Tabulated values for Hilti Kwik-Cons are based on the following: anchors are spaced at 2-3/4" o.c. (min.), anchors are placed 3/4" (min.) away from edge of building structure and 1/2" (min.) away from edge of Fast Strut. The tabulated values are based on 3000psi normal weight concrete.
- 5 For 3/4" deflection, center the propriety screws along the topmost hash mark. For 1-1/4" deflection, center the screws along the center hash mark.
- 6 Capacities listed for PAFs are based on minimum PAF requirements listed in General Note #6 on page 9.
- 7 It is the responsibility of the design professional to detail the project drawings for proper clip attachment.
- 8 Buildex is a registered trademark of Illinois Tool Works, Inc.
- 9 Hilti is a registered trademark of Hilti Aktiengesellschaft Corporation.

**TYPICAL CONSTRUCTION DETAILS**

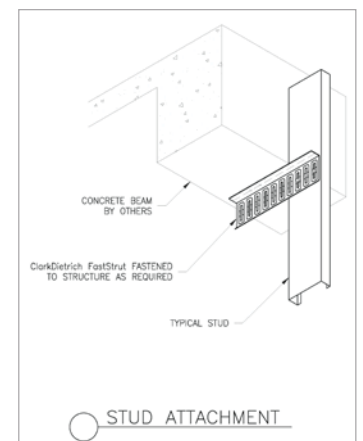
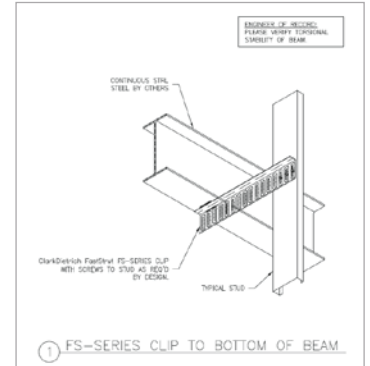

Visit our CAD Library at [clarkdietrich.com](http://clarkdietrich.com) to view or download construction details in .dwg, .dxf, and .pdf formats.

## Fixed Universal Slip Clip

### 10 and 12 gauge fixed universal slip clip.

The clips are available in standard lengths of 6" and 8" in 12 and 10 gauge. They are ideal for medium to larger standoff conditions. FUS clips install quickly and provide adjustable standoff to ensure a plumb wall plane. For deflection application, proprietary heavy duty deflection screws are provided with each clip to ensure friction-free sliding.

- Eliminates shims and scabs.
- Provides vertical movement up to 1" when installed as a deflection application
- Fast, one-piece universal installation. No left- or right-handed clips.
- Higher capacities when used in applications where significantly higher capacities are required.
- Proprietary heavy duty deflection screws provide frictionless slip connections.

### PRODUCT DIMENSIONS

Lengths: 6" or 8"

### MATERIAL SPECIFICATIONS

**Gauge:** 12 gauge (97mils)

**Design Thickness:** 0.1017 inches

**Gauge:** 10 gauge (118mils)

**Design Thickness:** 0.1242 inches

**Coating:** G90 (Z275 hot-dipped galvanized coating)

**Material:** Structural Grade 50 Type H (ST50H), 50ksi

**ASTM:** A653/A653M, ASTM A1003

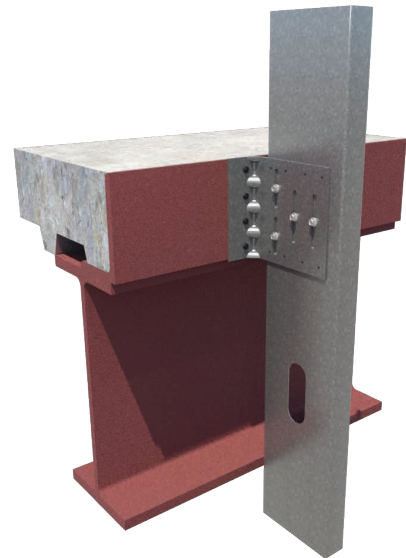
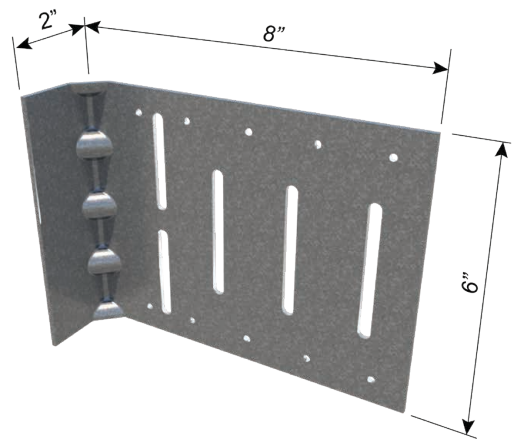
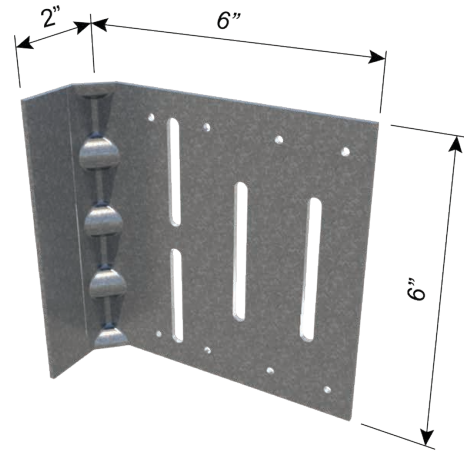

### Fixed Universal Slip Clip (FUS6, FUS8)

Product code	Thickness		Clip length (in)	Packaging Pcs./Box
	Mils (Gauge)	Design thickness (in)		
FUS6-97	97mils (12ga)	0.1017	6	10
FUS8-97			8	10
FUS6-118	118mils (10ga)	0.1242	6	10
FUS8-118			8	10

**INSTALLATION**

Connections to the building can be made with screws, welds powder-actuated fasteners. Mechanical fasteners shall be located on the embossed marks given on the scored line of the 2" flange. Attach building anchors to the structure according to the manufacturer's instructions. Anchors shall be installed through the embossments on the scored line of the clip as shown on the attached drawings. In no case shall anchors be installed more than 3/4" from the bend on the short leg of the clip. In cases of discrepancy between this information and the Design Engineer's details, the Design Engineer's details shall be followed.

**For a Deflection Connection:**

Attach the FUS clip to cold-formed steel framing members using proprietary #14 heavy duty deflection screws (included) through the slotted holes and position for the appropriate building deflection. For the FUS6 clip all slotted holes shall have a screw. For the FUS8 clip the (2) outer slotted holes and the (2) stacked slotted holes must have screws. For a deflection connection, screws should not be installed in any unslotted holes.

**Proprietary HD Deflection Screws:**

Many of the ClarkDietrich deflection clips include our proprietary heavy duty deflection fasteners that have been specifically designed to provide friction-free deflection. These fasteners eliminate drag, binding or resistance that can often occur with common fasteners. For the FUS clip, we supply a heavy duty version of the deflection screw. ClarkDietrich's Proprietary HD screws are utilized on the FUS clip only when used for a deflection condition.

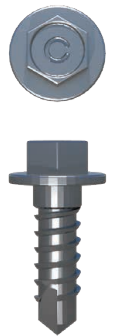

Proprietary HD Deflection Screws

Fixed Universal Slip Clip Design Capacities					DEFLECTION CONNECTIONS		
Product code	Clip thickness Mils (Gauge)	Clip length (in)	No. of #14 screws to framing	Stud thickness Mils (Gauge)	Capacities (lbs)		
					In-Plane F1	Tension F2	Compression F3
FUS6-97	97mils (12ga)	6	4	33mils (20ga)	115	922	1030
				43mils (18ga)	194	1288	1429
				54mils (16ga)	280	1689	1866
				68mils (14ga)	443	1928	2339
				97mils (12ga)	780	2423	3318
FUS8-97	97mils (12ga)	8	4	33mils (20ga)	115	922	1030
				43mils (18ga)	206	1288	1347
				54mils (16ga)	306	1689	1693
				68mils (14ga)	457	1947	2283
FUS6-118	118mils (10ga)	6	4	33mils (20ga)	137	1134	998
				43mils (18ga)	211	1550	1607
				54mils (16ga)	291	2006	2275
				68mils (14ga)	450	2458	2812
				97mils (12ga)	779	3392	3923
FUS8-118	118mils (10ga)	8	4	33mils (20ga)	137	1134	998
				43mils (18ga)	240	1550	1581
				54mils (16ga)	354	2006	2221
				68mils (14ga)	536	2458	2797
				97mils (12ga)	913	3392	3987

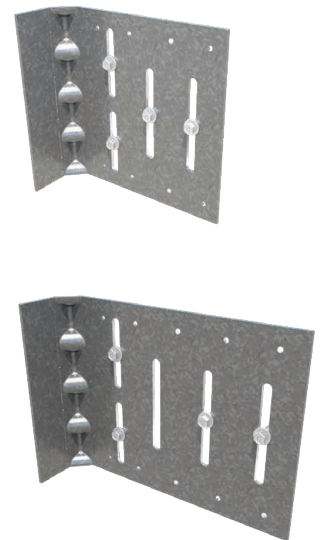

**Notes:**

- 1 Tabulated loads are based on testing with 600S162 CFS framing members.
- 2 Tabulated loads are based on single test conducted with two clips per test
- 3 Tabulated loads are based on maximum stud standoff distance of 1" from base structure.
- 4 FUS clip was tested in compliance with ICC-ES AC-261 (2019).
- 5 #14 shouldered screws (proprietary) were used to attach clips to framing members.
- 6 The ultimate screw shear strength and screw tension strength for #14 screws shall be at least 3048-lbs, and 3201-lbs respectively.
- 7 The screw strength capacities are based of CFSEI Tech Note (F701-12).
- 8 Allowable loads have not been increased for seismic or wind.

Product Detail

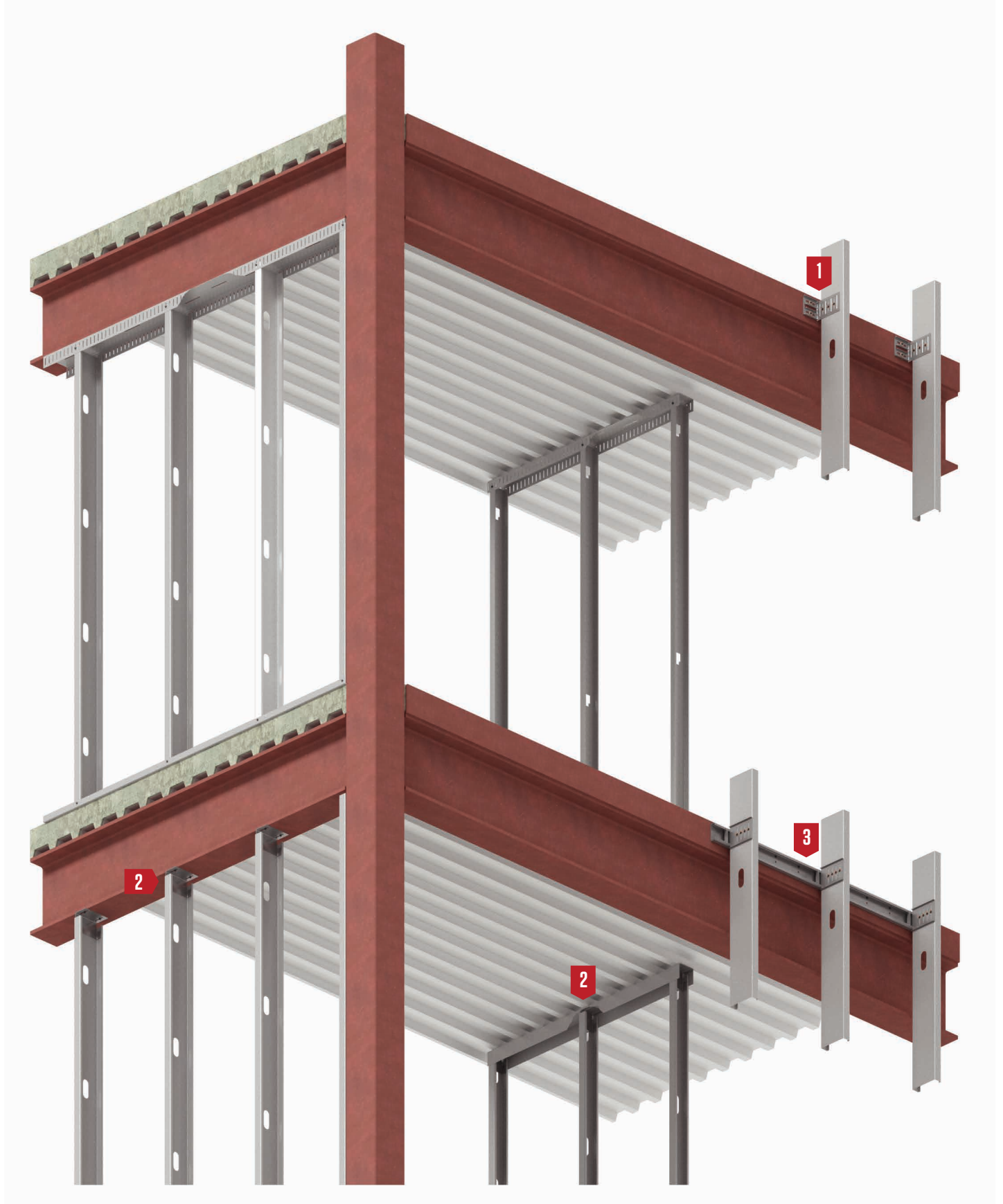



**1** Drift FastClip™ Slide Clip  
pages 46–49

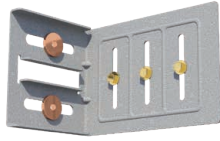

**2** Drift Head-of-Wall Clip  
pages 50–53

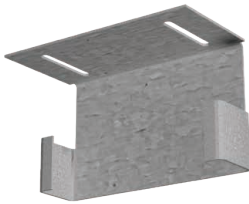

**3** Drift Rail and Clip  
Drift Headed Rail & Clip  
pages 54–71

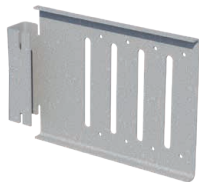

## Drift FastClip™ Slide Clip - 68mils (14ga)

Curtain Wall/Bypass with Drift & Vertical Deflection

Vertical and lateral building movement up to 2".

ClarkDietrich Drift FastClip™ Slide Clip 68mils (14ga) is used to attach exterior curtain-wall studs to the building structure and provide for both vertical and lateral movement. Proprietary Deflection Screws are provided with each clip for attachment to the wall studs and allow for 2" vertical deflection (1" up and down) to ensure friction-free sliding. Step bushings are provided for the connection to the structure and allow for 2" lateral deflection (1" left and right).

### MATERIAL SPECIFICATIONS

- Gauge:** 14 gauge (68mils)
- Design Thickness:** 0.0713 inches
- Yield Strength:** 50ksi
- Coating:** G90
- ASTM:** A653/A1003

### PRODUCT DIMENSIONS

- D-FCSC3.5: 3-3/4" x 4" x 3-1/2" long
- D-FCSC6: 3-3/4" x 4" x 6" long
- D-FCSC8: 3-3/4" x 4" x 8" long

### ALTERNATIVE PRODUCTS

Drift Rail and Clip

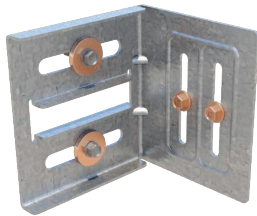

D-FCSC3.5

(2) Bushings per Clip  
(2) Slots & Deflection Screws per Clip

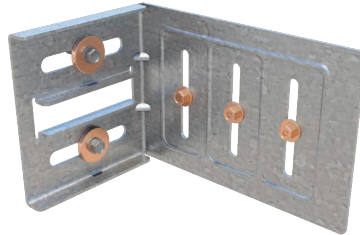

D-FCSC6

(2) Bushings per Clip  
(3) Slots & Deflection Screws per Clip

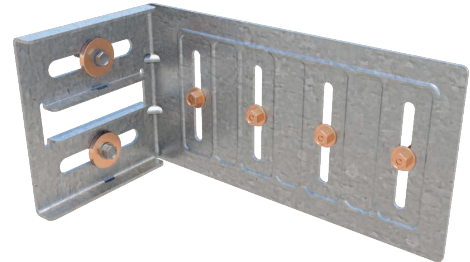

D-FCSC8

(2) Bushings per Clip  
(4) Slots & Deflection Screws per Clip

## Drift FastClip™ Slide Clip (D-FCSC)

Product code	Thickness		Size (in)	Packaging Pcs./Bucket
	Mils (Gauge)	Design thickness (in)		
D-FCSC3.5-68	68mils (14ga)	0.0713	3-3/4 x 4 x 3-1/2	25
D-FCSC6-68	68mils (14ga)	0.0713	3-3/4 x 4 x 6	25
D-FCSC8-68	68mils (14ga)	0.0713	3-3/4 x 4 x 7-3/4	25

Packaging:  
 D-FCSC3.5 includes (55) Proprietary Deflection Screws & (50) Bushings  
 D-FCSC6 includes (80) Proprietary Deflection Screws & (50) Bushings  
 D-FCSC8 includes (110) Proprietary Deflection Screws & (50) Bushings

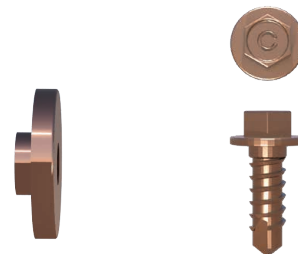

Copper Bushing for 14ga Clips

Proprietary Deflection Screws (For Stud Connection)

**INSTALLATION**

To attach the clip to the cold-formed steel framing, two, three or four Proprietary Deflection Screws (based upon clip size), shall be driven through the slotted holes and positioned to allow for the appropriate building deflection.

Attachment to the primary structure can be made with screws, or bolt anchors. Structure attachments shall be driven through the drift bushings and the Drift FastClip™ - centered in the drift slots.

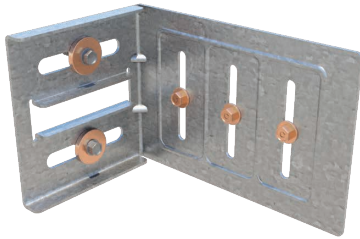

**STRUCTURE CENTER CONNECTION<sup>1</sup>**  
Drift Bushings centered in slots

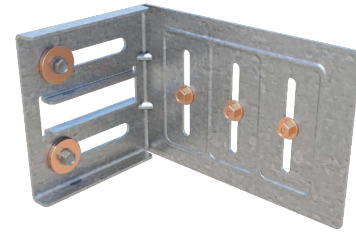

**STRUCTURE OFFSET CONNECTION<sup>2</sup>**  
Drift Bushings at far end of slots

Drift FastClip™ Slide Clip (D-FCSC) Allowable Loads				ATTACHED TO MIN. 3/16" STRUCTURAL STEEL WITH (2) 1/4"-20 SCREWS			
Clip designation	Stud thickness Mils (ga)	Fasteners		Tension or Compression Load Capacity			
		to Framing	to Structure	ASD		LRFD	
				Center (lbs)*	Offset (lbs)**	Center (lbs)*	Offset (lbs)**
D-FCSC3.5 68mils (14ga)	33mils (20ga) 33ksi	(2) Proprietary Deflection Screws	(2) 1/4" - 20 with Drift Bushing	395	383	632	613
	43mils (18ga) 33ksi			579	487	926	779
	54mils (16ga) 50ksi			612	526	979	841
	68mils (14ga) 50ksi			612	548	979	876
	97mils (12ga) 50ksi			648	548	1037	876
D-FCSC6 68mils (14ga)	33mils (20ga) 33ksi	(3) Proprietary Deflection Screws	(2) 1/4" - 20 with Drift Bushing	627	509	1003	815
	43mils (18ga) 33ksi			640	534	1024	855
	54mils (16ga) 50ksi			640	541	1024	866
	68mils (14ga) 50ksi			667	559	1067	895
	97mils (12ga) 50ksi			667	559	1067	895
D-FCSC8 68mils (14ga)	43mils (18ga) 33ksi	(4) Proprietary Deflection Screws	(2) 1/4" - 20 with Drift Bushing	597	499	955	798
	54mils (16ga) 50ksi			636	566	1018	906
	68mils (14ga) 50ksi			671	574	1074	918
	97mils (12ga) 50ksi			671	645	1074	1032

**Notes:**

- \* Proprietary Deflection Screws centered in slots, Drift bushings centered in slots.
- \*\* Proprietary Deflection Screws centered in slots, Drift bushings at end of slots.
- 1 Load capacities have not been increased for wind, seismic, or other factors.
- 2 Load Capacities include 1/8" service load limitation.
- 3 Load Capacities calculated considering (2) 1/4"-20 screws for structure connection to 3/16" steel.
- 4 Refer to ICC-ESR-3332 for allowable loads using 1/4"-20 screw fasteners with various plate connection thickness.
- 5 Proprietary Deflection Screws for framing connection and step bushings for structure connection are provided with D-FCSC clip.

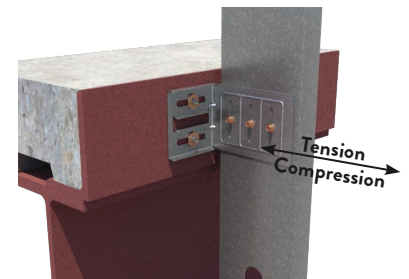

## Drift FastClip™ Slide Clip - 97mils (12ga)

Curtain Wall/Bypass with Drift & Vertical Deflection

Vertical and lateral building movement up to 2".

ClarkDietrich Drift FastClip™ Slide Clip 97mils (12ga) is used to attach exterior curtain-wall studs to the building structure and provide for both vertical and lateral movement. Proprietary HD Deflection Screws are provided with each clip for attachment to the wall studs and allow for 2" vertical deflection (1" up and down) to ensure friction-free sliding. Step bushings are provided for the connection to the structure and allow for 2" lateral deflection (1" left and right).

### MATERIAL SPECIFICATIONS

- Gauge:** 12 gauge (97mils)
- Design Thickness:** 0.1017 inches
- Yield Strength:** 50ksi
- Coating:** G90
- ASTM:** A653/A1003

### PRODUCT DIMENSIONS

- D-FCSC3.5: 3-3/4" x 4" x 3-1/2" long
- D-FCSC6: 3-3/4" x 4" x 6" long
- D-FCSC8: 3-3/4" x 4" x 8" long

### ALTERNATIVE PRODUCTS

Drift Rail and Clip

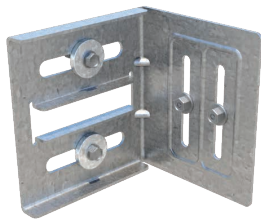

D-FCSC3.5

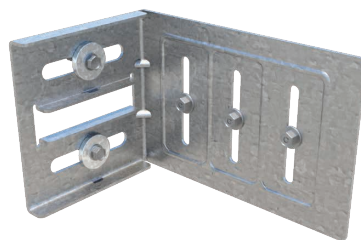

D-FCSC6

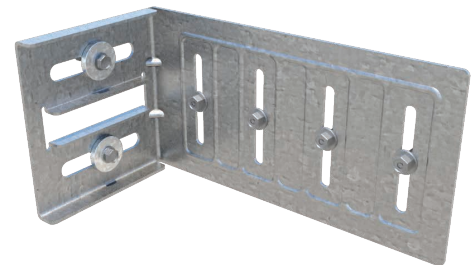

D-FCSC8

## Drift FastClip™ Slide Clip (D-FCSC)

Product code	Thickness		Size (in)	No. of Bushings per Clip	No. of Slots & Deflection Screws per Clip
	Mils (Gauge)	Design thickness (in)			
D-FCSC3.5-97	97mils (12ga)	0.1017	3-1/2"	2	2
D-FCSC6-97	97mils (12ga)	0.1017	6"	2	3
D-FCSC8-97	97mils (12ga)	0.1017	7-3/4"	2	4

Packaging: 25 Clips per Bucket

D-FCSC3.5 includes (55) Proprietary HD Deflection Screws & (50) Bushings

D-FCSC6 includes (80) Proprietary HD Deflection Screws & (50) Bushings

D-FCSC8 includes (110) Proprietary HD Deflection Screws & (50) Bushings

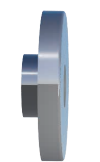

Silver Bushing for 12ga Clips



Proprietary HD Deflection Screws (10ga and 12ga clips only)

**INSTALLATION**

To attach the clip to the cold-formed steel framing, two, three or four Proprietary HD Deflection Screws (based upon clip size), shall be driven through the slotted holes and positioned to allow for the appropriate building deflection.

Attachment to the primary structure can be made with screws, or bolt anchors. Structure attachments shall be driven through the drift bushings and the Drift FastClip™ - centered in the drift slots.

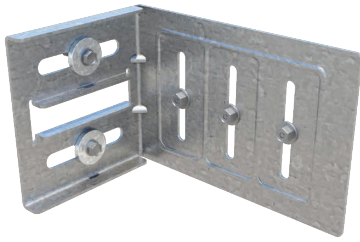

**STRUCTURE CENTER CONNECTION<sup>1</sup>**  
Drift Bushings centered in slots

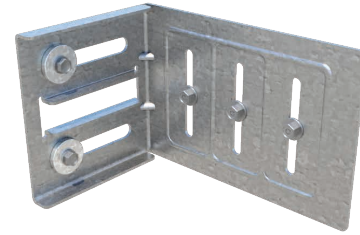

**STRUCTURE OFFSET CONNECTION<sup>2</sup>**  
Drift Bushings at far end of slots

**Drift FastClip™ Slide Clip (D-FCSC) Allowable Loads** ATTACHED TO MIN. 3/16" STRUCTURAL STEEL WITH (2) 1/4"-20 SCREWS

Clip designation	Stud thickness Mils (Gauge)	Fasteners		Tension or Compression Load Capacity			
		to Framing	to Structure	ASD		LRFD	
				Center (lbs)*	Offset (lbs)**	Center (lbs)*	Offset (lbs)**
D-FCSC3.5 97mils (12ga)	33mils (20ga) 33ksi	(2) Proprietary HD Deflection Screws	(2) 1/4" - 20 with Drift Bushing	488	443	781	709
	43mils (18ga) 33ksi			740	499	1183	798
	54mils (16ga) 50ksi			877	877	1402	1402
	68mils (14ga) 50ksi			877	877	1402	1402
	97mils (12ga) 50ksi			877	877	1402	1402
D-FCSC6 97mils (12ga)	33mils (20ga) 33ksi	(3) Proprietary HD Deflection Screws	(2) 1/4" - 20 with Drift Bushing	777	592	1243	948
	43mils (18ga) 33ksi			934	934	1494	1494
	54mils (16ga) 50ksi			978	967	1564	1548
	68mils (14ga) 50ksi			978	967	1564	1548
	97mils (12ga) 50ksi			978	967	1564	1548
D-FCSC8 97mils (12ga)	43mils (18ga) 33ksi	(4) Proprietary HD Deflection Screws	(2) 1/4" - 20 with Drift Bushing	822	822	1316	1316
	54mils (16ga) 50ksi			845	845	1353	1353
	68mils (14ga) 50ksi			845	845	1353	1353
	97mils (12ga) 50ksi			845	845	1353	1353

**Notes:**

- \* Proprietary HD Deflection Screws centered in slots, Drift bushings centered in slots.
- \*\* Proprietary HD Deflection Screws centered in slots, Drift bushings at end of slots.
- 1 Load capacities have not been increased for wind, seismic, or other factors.
- 2 Load capacities include 1/8" service load limitation.
- 3 Load capacities calculated considering (2) 1/4"-20 screws for structure connection to 3/16" steel.
- 4 Refer to ICC-ESR-3332 for allowable loads using 1/4"-20 screw fasteners with various plate connection thickness.
- 5 Proprietary HD Deflection Screws for framing connection and step bushings for structure connection are provided with D-FCSC clip.

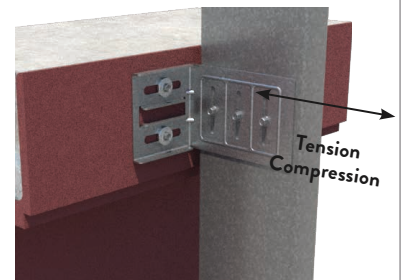

## Drift Head-of-Wall

### Head-of-wall drift and deflection connection

#### Head-of-wall drift and deflection for exterior curtain wall and interior nonload-bearing walls

ClarkDietrich's Drift Head-of-wall Clips are used in deflection conditions for in-fill curtain wall assemblies and/or interior nonload-bearing partitions to provide for both vertical (deflection) and lateral (drift) movement. These clips are used in place of, or in combination with, deflection track.

The Drift Head-of-wall Clips can be attached to the underside of structural members, concrete decks or floor assemblies. Structural attachments are positioned in the center of the slot to allow building drift. The "C" shaped end of the clip is slid inside of the structural stud and not fastened allowing for vertical deflection. Studs must be cut less than full height to enable vertical movement up to 2" (1" up and down).

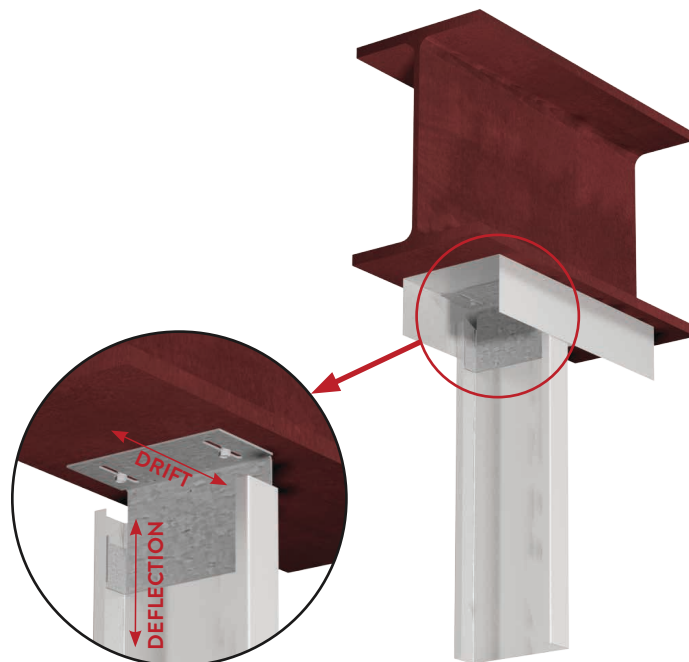

#### MATERIAL SPECIFICATIONS

**Gauge:** 14 gauge (68mils)

**Design Thickness:** 0.0713 inches

**Yield Strength:** 50ksi

**Coating:** G90

**ASTM:** A653/A653M

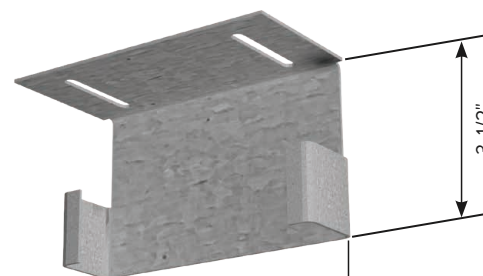

DHOW3-LG=3-1/2"  
DHOW6-LG=5-7/8"  
DHOW8-LG=7-7/8"

DHOW3-HG=3-5/16"  
DHOW6-HG=5-11/16"  
DHOW8-HG=7-11/16"

Patent Pending

#### DHOW-LG Systems

For attaching 20ga (33mils), 18ga (43mils), or 16ga (54mils) structural studs

Product code	Thickness	Design thickness	Size (in)	Packaging pcs./bucket
	Mils (Gauge)			
DHOW3-LG	68mils (14ga)	0.0713	3-1/2"	25
DHOW6-LG			5-7/8"	
DHOW8-LG			7-7/8"	

#### DHOW-HG Systems

For attaching 14ga (68mils) or 12ga (97mils) structural studs

Product code	Thickness	Design thickness	Size (in)	Packaging pcs./bucket
	Mils (Gauge)			
DHOW3-HG	68mils (14ga)	0.0713	3-5/16"	25
DHOW6-HG			5-11/16"	
DHOW8-HG			7-11/16"	

#### INSTALLATION

The Drift HOW clips come in two designs. The DHOW-LG (light gauge) is designed to be installed in structural stud gauges 20ga (33mils), 18ga (43mils) or 16ga (54mils). The DHOW-HG (heavy gauge) is designed to be installed in structural stud gauges 14ga (68mils) and 12ga (97mils). Attachment to the primary structure can be made with 1/4-14 screws, or concrete anchors and shall be driven through the slotted holes and positioned in the center of the slot to allow building drift. To ensure slip, back-out the fasteners about 1/2" turn. The "C" shaped end of the clip is slid inside of the structural stud and is not fastened, which allows for vertical deflection. Drywall screws (in the stud) shall be placed no closer than 4" from the slotted leg of the clip.

Drift Head-of-Wall (DHOW3)			ALLOWABLE LOADS		
Clip designation	Stud thickness Mils (Gauge)	Yield strength (ksi)	Anchors to structure	ASD Allowable Loads (lbs)	
				Vertical Displacement	
				Center ( $\pm 1"$ )	Offset (+2" / -0")
DHOW3-LG	33mils (20ga)	33ksi	Anchors to be designed by others	120	90
	43mils (18ga)	33ksi		210	130
	54mils (16ga)	50ksi		360	210
DHOW3-HG	68mils (14ga)	50ksi		510	260
	97mils (12ga)	50ksi		590	360

Drift Head-of-Wall (DHOW3) w/Fasteners			ALLOWABLE LOADS		
Clip designation	Stud thickness Mils (Gauge)	Yield strength (ksi)	Anchors to structure	ASD Allowable Loads (lbs)	
				Vertical Displacement	
				Center ( $\pm 1"$ )	Offset (+2" / -0")
DHOW3-LG	33mils (20ga)	33ksi	(2) 1/4-14 Fasteners in 3/16" Steel	120	90
	43mils (18ga)	33ksi		210	130
	54mils (16ga)	50ksi		360	210
DHOW3-HG	68mils (14ga)	50ksi		510	260
	97mils (12ga)	50ksi		590	360
DHOW3-LG	33mils (20ga)	33ksi		(2) 1/4" Hilti Kwik HUS-EZ (2-1/2" Embedment in to 3000 psi cracked concrete)	120
	43mils (18ga)	33ksi	210		130
	54mils (16ga)	50ksi	360		210
DHOW3-HG	68mils (14ga)	50ksi	510		260
	97mils (12ga)	50ksi	590		360

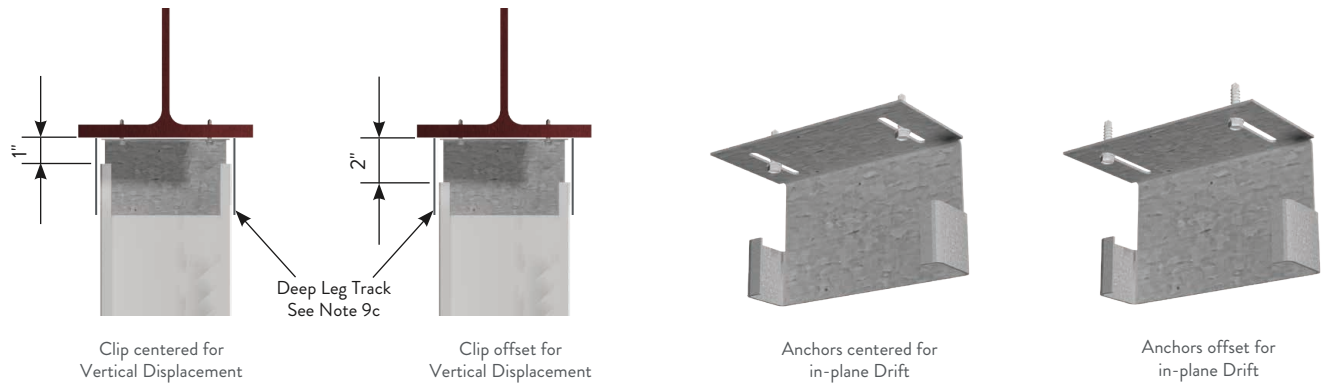

**Notes:**

- 1 Table 1 capacities represent the capacity of the clip and the stud connection.
- 2 Table 2 considers capacities when the specified connectors to the structure described in notes 3 and 4 are used.
- 3 (2) 1/4-14 Fasteners shall be used for attachment to steel structure.
- 4 (2) 1/4 Hilti Kwik HUS-EZ Anchors shall be used for attachment to concrete structure.
- 5 Capacities listed in the table/notes do not consider load adjustment for edge distance of concrete anchors. For no reduction in the listed capacities of 1/4" Hilti KWIK HUS-EZ anchors embedded 2-1/2" deep into 3000psi concrete, the following minimum edge distance shall be met:
  - a 4-1/2" for uncracked concrete
  - b 4-1/2" for cracked concrete
- 6 To minimize the torsional effects of the stud, place stud bridging 12" from the end of the stud.
- 7 Drywall screw (in stud) shall be placed no closer than 4" from the slotted leg of the clip.
- 8 Allowable loads have not been increased for wind, seismic, or other factors.
- 9 Head-of-Wall Drift clip allows up to ( $\pm 1"$ ) of vertical displacement, and ( $\pm 1"$ ) of drift in the plane of the wall.
  - a "Center" capacity is for the center configuration of both Drift and Vertical Displacement.
  - b "Offset" capacity is for the offset configuration of both Drift and Vertical Displacement.
  - c If a deflection track is used, use a 2-1/2" (min) leg track so the stud does not disengage the track.
- 10 To ensure slip,
  - a Concrete fasteners shall not be driven completely flush against the connector.
  - b Structural steel fasteners -once tightened, back-out the fasteners in steel about 1/2 turn.

## Drift Head-of-Wall

## Head-of-wall drift and deflection connection

## Drift Head-of-Wall (DHOW6)

## ALLOWABLE LOADS

Clip designation	Stud thickness Mils (Gauge)	Yield strength (ksi)	Anchors to structure	ASD Allowable Loads (lbs)	
				Vertical Displacement	
				Center ( $\pm 1"$ )	Offset ( $+2" / -0"$ )
DHOW6-LG	33mils (20ga)	33ksi	Anchors to be designed by others	220	196
	43mils (18ga)	33ksi		340	248
	54mils (16ga)	50ksi		515	261
DHOW6-HG	68mils (14ga)	50ksi		515	275
	97mils (12ga)	50ksi		625	340

## Drift Head-of-Wall (DHOW6) w/Fasteners

## ALLOWABLE LOADS

Clip designation	Stud thickness Mils (Gauge)	Yield strength (ksi)	Anchors to structure	ASD Allowable Loads (lbs)	
				Vertical Displacement	
				Center ( $\pm 1"$ )	Offset ( $+2" / -0"$ )
DHOW6-LG	33mils (20ga)	33ksi	(2) 1/4-14 Fasteners in 3/16" Steel	220	196
	43mils (18ga)	33ksi		340	248
	54mils (16ga)	50ksi		515	261
DHOW6-HG	68mils (14ga)	50ksi		515	275
	97mils (12ga)	50ksi		625	340
	DHOW6-LG	33mils (20ga)		33ksi	(2) 1/4" Hilti Kwik HUS-EZ (2-1/2" Embedment in to 3000 psi cracked concrete)
43mils (18ga)		33ksi	340	248	
54mils (16ga)		50ksi	515	261	
DHOW6-HG	68mils (14ga)	50ksi	515	275	
	97mils (12ga)	50ksi	625	340	

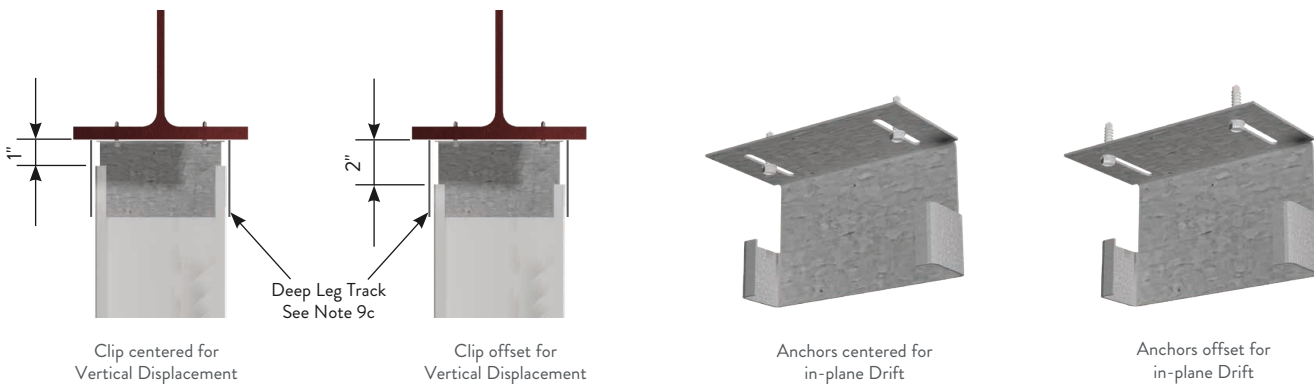

## Notes:

- 1 Table 1 capacities represent the capacity of the clip and the stud connection.
- 2 Table 2 considers capacities when the specified connectors to the structure described in notes 3 and 4 are used.
- 3 (2) 1/4-14 Fasteners shall be used for attachment to steel structure.
- 4 (2) 1/4 Hilti Kwik HUS-EZ Anchors shall be used for attachment to concrete structure.
- 5 Capacities listed in the table/notes do not consider load adjustment for edge distance of concrete anchors. For no reduction in the listed capacities of 1/4" Hilti KWIK HUS-EZ anchors embedded 2-1/2" deep into 3000psi concrete, the following minimum edge distance shall be met:
  - a 4-1/2" for uncracked concrete
  - b 4-1/2" for cracked concrete
- 6 To minimize the torsional effects of the stud, place stud bridging 12" from the end of the stud.
- 7 Drywall screw (in stud) shall be placed no closer than 4" from the slotted leg of the clip.
- 8 Allowable loads have not been increased for wind, seismic, or other factors.
- 9 Head-of-Wall Drift clip allows up to ( $\pm 1"$ ) of vertical displacement, and ( $\pm 1"$ ) of drift in the plane of the wall.
  - a "Center" capacity is for the center configuration of both Drift and Vertical Displacement.
  - b "Offset" capacity is for the offset configuration of both Drift and Vertical Displacement.
  - c If a deflection track is used, use a 2-1/2" (min) leg track so the stud does not disengage the track.
- 10 To ensure slip,
  - a Concrete fasteners shall not be driven completely flush against the connector.
  - b Structural steel fasteners -once tightened, back-out the fasteners in steel about 1/2 turn.



### Drift Head-of-Wall (DHOW8)

### ALLOWABLE LOADS

Clip designation	Stud thickness Mils (Gauge)	Yield strength (ksi)	Anchors to structure	ASD Allowable Loads (lbs)	
				Vertical Displacement	
				Center ( $\pm 1"$ )	Offset (+2" / -0")
DHOW8-LG	33mils (20ga)	33ksi	Anchors to be designed by others	-	-
	43mils (18ga)	33ksi		120	110
	54mils (16ga)	50ksi		200	160
DHOW8-HG	68mils (14ga)	50ksi		260	190
	97mils (12ga)	50ksi		420	280

### Drift Head-of-Wall (DHOW8) w/Fasteners

### ALLOWABLE LOADS

Clip designation	Stud thickness Mils (Gauge)	Yield strength (ksi)	Anchors to structure	ASD Allowable Loads (lbs)	
				Vertical Displacement	
				Center ( $\pm 1"$ )	Offset (+2" / -0")
DHOW8-LG	33mils (20ga)	33ksi	(2) 1/4-14 Fasteners in 3/16" Steel	-	-
	43mils (18ga)	33ksi		120	110
	54mils (16ga)	50ksi		200	160
DHOW8-HG	68mils (14ga)	50ksi		260	190
	97mils (12ga)	50ksi		420	280
	DHOW8-LG	33mils (20ga)		33ksi	(2) 1/4" Hilti Kwik HUS-EZ (2-1/2" Embedment in to 3000 psi cracked concrete)
43mils (18ga)		33ksi	120	110	
54mils (16ga)		50ksi	200	160	
DHOW8-HG	68mils (14ga)	50ksi	260	190	
	97mils (12ga)	50ksi	420	280	

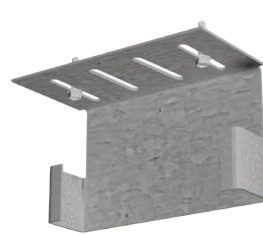
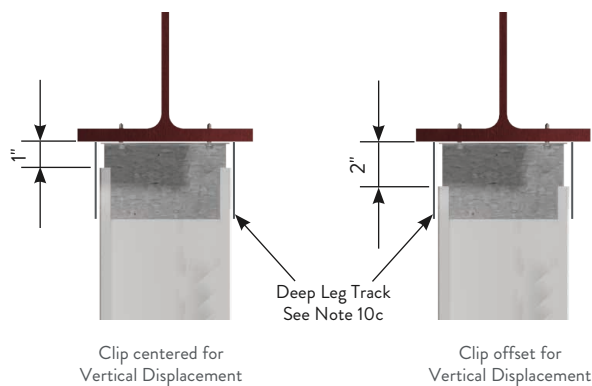

Anchors centered for in-plane Drift

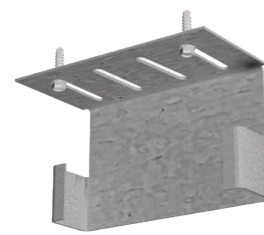

Anchors offset for in-plane Drift

#### Notes:

- 1 Table 1 capacities represent the capacity of the clip and the stud connection.
- 2 Table 2 considers capacities when the specified connectors to the structure described in notes 3 and 4 are used.
- 3 (2) 1/4-14 Fasteners shall be used for attachment to steel structure.
- 4 (2) 1/4 Hilti Kwik HUS-EZ Anchors shall be used for attachment to concrete structure.
- 5 For the (2) fasteners attached to the structure, each fastener shall be installed in the any two slots of the clip leg.
- 6 Capacities listed in the table/notes do not consider load adjustment for edge distance of concrete anchors. For no reduction in the listed capacities of 1/4" Hilti KWIK HUS-EZ anchors embedded 2-1/2" deep into 3000psi concrete, the following minimum edge distance shall be met:
  - a 4-1/2" for uncracked concrete
  - b 4-1/2" for cracked concrete
- 7 To minimize the torsional effects of the stud, place stud bridging 12" from the end of the stud.
- 8 Drywall screw (in stud) shall be placed no closer than 4" from the slotted leg of the clip.
- 9 Allowable loads have not been increased for wind, seismic, or other factors.
- 10 Head-of-Wall Drift clip allows up to ( $\pm 1"$ ) of vertical displacement, and ( $\pm 1"$ ) of drift in the plane of the wall.
  - a "Center" capacity is for the center configuration of both Drift and Vertical Displacement.
  - b "Offset" capacity is for the offset configuration of both Drift and Vertical Displacement.
  - c If a deflection track is used, use a 2-1/2" (min) leg track so the stud does not disengage the track.
- 11 To ensure slip,
  - a Concrete fasteners shall not be driven completely flush against the connector.
  - b Structural steel fasteners -once tightened, back-out the fasteners in steel about 1/2 turn.

## Drift Rail and Clip

### Curtain Wall/Bypass with Drift and Vertical Deflection

#### Vertical and lateral building movement

ClarkDietrich Drift Rail (DR) or Drift Headed Rail (DHR) with Drift Rail Clip (DRC), is a uniquely designed two-piece system that is used to attach curtain-wall studs to the building structure and allows for vertical and lateral movement or to be rigidly attached. The system utilizes a C-Shaped Drift Rail and distinctively designed Drift Rail Clips that rotate into position for easy installation. The multifaceted Drift Rail Clips use Proprietary Deflection Screws for attachment to the wall studs and allows for 3" vertical deflection (1-1/2" up and down) and is also designed with 1/8" holes to rigidly attach wall studs.

#### MATERIAL SPECIFICATIONS

**Yield Strength:** 50ksi  
**Coating:** G90  
**ASTM:** A653 / A1003

#### DRIFT RAIL (S)

**Gauge:** 12ga (97mils)  
**Design Thickness:** 0.1017"  
**Min. Thickness:** 0.0966"

#### HEADED STUD MATERIAL SPECIFICATIONS

**Yield Strength:** Grade 1010 through 1020, 51ksi  
**ASTM:** A29/A108  
**AWS:** D1.1  
**Dimensions:** 3/8" dia. x 3" long with 3/4" head dia.

#### DRIFT RAIL CLIP

<b>Gauge:</b> 12ga (97mils)	<b>Gauge:</b> 14ga (68mils)
<b>Design Thickness:</b> 0.1017"	<b>Design Thickness:</b> 0.0713"
<b>Min. Thickness:</b> 0.0966"	<b>Min. Thickness:</b> 0.0677"

#### ALTERNATIVE PRODUCTS

Drift FastClip™ Slide Clip

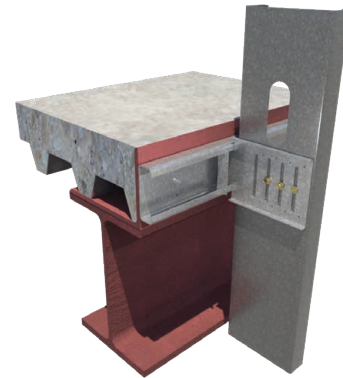

Drift Rail  
(DR) Installation

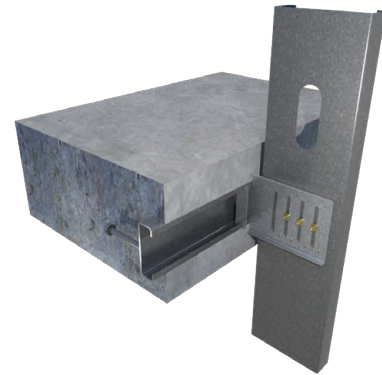

Drift Headed Rail  
(DHR) Installation

**DRC - 12ga Clip / 12ga Rail**

Product code	Thickness	Size (in)	No. of slots per Clip	No. of holes per clip	Drift Clips per box	Prop. Screws per box
	Mils (Gauge)					
DRC3-97	97mils (12ga)	3.3875"	2	4	25	55 or 80
DRC6-97		5.875"	4	8	25	55 or 80
DRC8-97		7.325"	4	8	25	55 or 80

**DRC - 14ga Clip / 12ga Rail**

Product code	Thickness	Size (in)	No. of slots per Clip	No. of holes per clip	Drift Clips per box	Prop. Screws per box
	Mils (Gauge)					
DRC3-68	68mils (14ga)	3.3875"	2	4	25	55 or 80
DRC6-68		5.875"	4	8	25	55 or 80
DRC8-68		7.325"	4	8	25	55 or 80

Note: 12' Drift Rail(s) are individually packaged.



Proprietary Deflection Screw



Proprietary HD Deflection Screw (10ga and 12ga Clips Only)

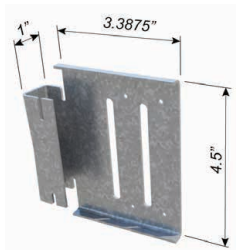

DRC3

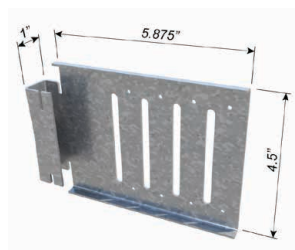

DRC6

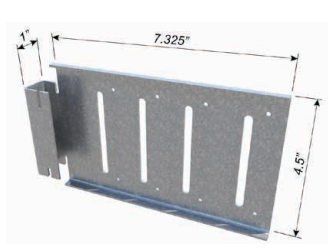

DRC8

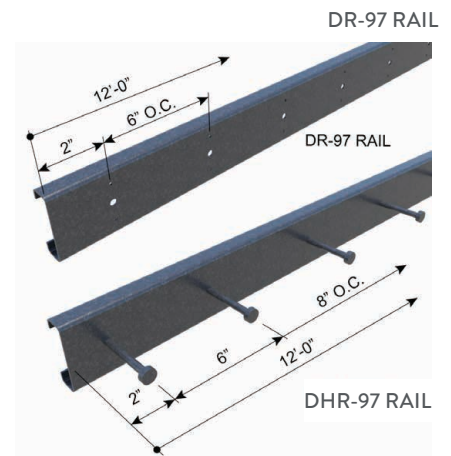

## Drift Rail and Clip

### INSTALLATION

Install the Drift Rail to minimum 3/16-in thick **steel** support structure using:

- Welds
- PAF fasteners
- Self-drilling screws

Install the Drift Rail to **concrete** support structure using:

- Expansion anchors
- Screw anchors
- Cast In Place / Embedded (Drift Headed Rail only)

Pilot holes are provided along the length of the Drift Rail web at a spacing of 6-in on-center. (DR rail only)

Design load capacities for commonly used fasteners are tabulated in the product Design Guide and include:

- Hilti X-U Universal Knurled Shank Fasteners
- #12-24 HWH Fasteners
- Hilti 1/4" KWIK HUS-EZ anchor

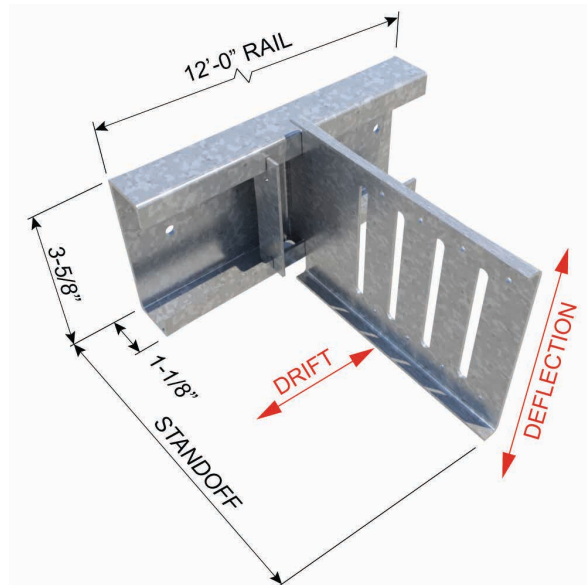

With the Drift Rail or Drift Headed Rail installed on the structure, the Drift Clips can be positioned as required:

- The framing stud web must contact the flat face of the long leg of the Drift Clip.
- Note that one of the four slots in the channel portion of the Drift Clip is longer than the others.
- Tilt the Drift Clip and position it so that the longer slot initially engages one leg of the Drift Rail.
- Rotate the Drift Clip to the vertical position, engaging all four slots with the Drift Rail legs.

### Connection between the Drift Clip and Framing Studs:

- For bypass connections, Proprietary Deflection Screws are placed through each slotted hole of the long leg, of the Drift Clip to the web of the stud. The required number and location of the slotted holes used to secure the stud is determined by the required design load capacity.
- For rigid connections, self-drilling screws are placed through the pilot holes around the perimeter of the long leg of the Drift Clip to the web of the stud.

To restrict clip lateral movement (Drift) along the Drift Rail, install one of two types of stops:

- Drift Locking Angle (DRLA) is an L-shaped clip
  - The long leg is inserted into the channel of the Drift Rail Clip,
  - The short leg is secured to the flange of the Drift Rail with a #10 self-drilling screw
- Drift Locking Clip (DRLC) is a C-shaped clip
  - The DRLC sits within the channel of the Drift Clip, and straddles the flanges of the Drift Rail.
  - The two outside legs of the DRLC are secured to each flange of the Drift Rail with a #10 self-drilling screw.

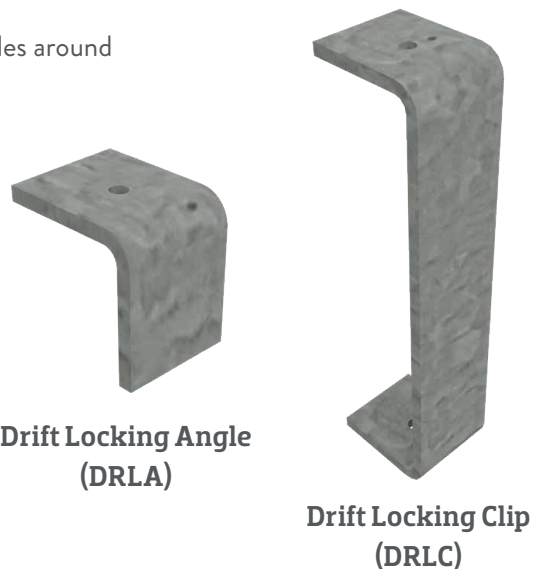

## Drift Rail and Clip - Structural Attachment Designed by Others

ATTACHMENT TO STRUCTURAL: **DESIGNED BY OTHERS**  
 ATTACHMENT TO STUD: **AS A DEFLECTION CONNECTION**

### Drift Rail and Clip - 12ga Clip / 12ga Rail

### ALLOWABLE DRIFT RAIL CLIP LOADS USING CLIP AS A DEFLECTION CONNECTION

Product code	Stud Mils (Gauge)	Framing Connection		ASD Allowable Loads (lbs)	
		Screw Pattern	No. of Screws	F2 (Tension)	F3 (Compression)
DRC3-97	33mils (20ga)	See Figure	(2) x #14	560	600
	43mils (18ga)		(2) x #14	655	670
	54mils (16ga)		(2) x #14	1000	970
	68mils (14ga)		(2) x #14	1085	1325
	97mils (12ga)		(2) x #14	1085	2040
DRC6-97	33mils (20ga)	See Figure	(3) x #14	560	600
	43mils (18ga)		(3) x #14	655	670
	54mils (16ga)		(3) x #14	1000	970
	68mils (14ga)		(3) x #14	1085	1325
	97mils (12ga)		(3) x #14	1085	2040
DRC8-97	33mils (20ga)	See Figure	(3) x #14	560	620
	43mils (18ga)		(3) x #14	655	730
	54mils (16ga)		(3) x #14	1000	1060
	68mils (14ga)		(3) x #14	1085	1340
	97mils (12ga)		(3) x #14	1085	1965

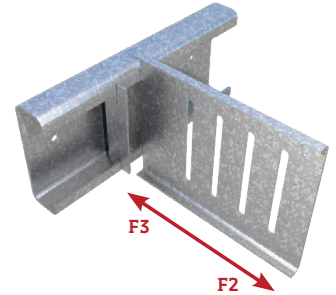

### Drift Rail and Clip - 14ga Clip / 12ga Rail

### ALLOWABLE DRIFT RAIL CLIP LOADS USING CLIP AS A DEFLECTION CONNECTION

Product code	Stud Mils (Gauge)	Framing Connection		ASD Allowable Loads (lbs)	
		Screw Pattern	No. of Screws	F2 (Tension)	F3 (Compression)
DRC3-68	33mils (20ga)	See Figure	(2) x #14	490	440
	43mils (18ga)		(2) x #14	540	520
	54mils (16ga)		(2) x #14	850	870
	68mils (14ga)		(2) x #14	850	1170
	97mils (12ga)		(2) x #14	850	1600
DRC6-68	33mils (20ga)	See Figure	(3) x #14	490	440
	43mils (18ga)		(3) x #14	540	520
	54mils (16ga)		(3) x #14	850	870
	68mils (14ga)		(3) x #14	850	1170
	97mils (12ga)		(3) x #14	850	1600
DRC8-68	33mils (20ga)	See Figure	(3) x #14	490	485
	43mils (18ga)		(3) x #14	540	620
	54mils (16ga)		(3) x #14	850	900
	68mils (14ga)		(3) x #14	850	1105
	97mils (12ga)		(3) x #14	850	1710

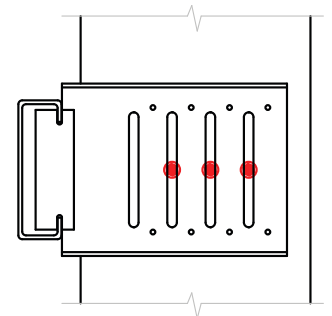

(3) #14 Deflection Screw Pattern  
 Shown in a DRC6 Clip

**Notes:**

- 1 Allowable loads (ASD) listed are for Drift Rail Clip to stud only (framing connection).
- 2 Drift Rail attachment to structure designed by others. Drift Rail attachment to the structure should occur at every 6" o.c., and each connection capacity should satisfy the design load requirement of the project. Listed Drift Rail clip load capacities must be evaluated along with clip-to-structure connection capacity to establish the governing load capacity of the assembly.
- 3 Allowable loads have not been increased for wind, seismic, or other factors.
- 4 Minimum (2) x #14 shouldered screws (for DRC3) and (3) x #14 shouldered screws (for DRC6 and DRC8) must be used to secure the Drift Rail Clip for attachment to stud (#14 shouldered screws provided with each Drift Rail Clip).
- 5 It is the responsibility of the designer to properly detail connections on the contract drawings.

## Drift Rail and Clip - Structural Attachment Designed by Others

ATTACHMENT TO STRUCTURAL: **DESIGNED BY OTHERS**  
 ATTACHMENT TO STUD: **FIXED CONNECTION W/(4)#10-16**

### Drift Rail and Clip - 12ga Clip / 12ga Rail

#### ALLOWABLE DRIFT RAIL CLIP LOADS USING CLIP AS A FIXED CONNECTION

Product code	Stud Mils (Gauge)	Framing Connection		ASD Allowable Loads (lbs)			
		Screw Pattern	No. of Screws	F1 (In-Plane)	F2 (Tension)	F3 (Compression)	F4 (Shear)
DRC3-97	33mils (20ga)	See Figure	(4) x #10	155	560	600	280
	43mils (18ga)		(4) x #10	155	655	670	415
	54mils (16ga)		(4) x #10	155	1000	970	840
	68mils (14ga)		(4) x #10	155	1085	1325	865
	97mils (12ga)		(4) x #10	155	1085	2040	865
DRC6-97	33mils (20ga)	See Figure	(4) x #10	155	560	600	235
	43mils (18ga)		(4) x #10	155	655	670	345
	54mils (16ga)		(4) x #10	155	1000	970	705
	68mils (14ga)		(4) x #10	155	1085	1325	725
	97mils (12ga)		(4) x #10	155	1085	2040	725
DRC8-97	33mils (20ga)	See Figure	(4) x #10	140	560	620	240
	43mils (18ga)		(4) x #10	140	655	730	360
	54mils (16ga)		(4) x #10	140	1000	1060	725
	68mils (14ga)		(4) x #10	140	1085	1340	745
	97mils (12ga)		(4) x #10	140	1085	1965	745

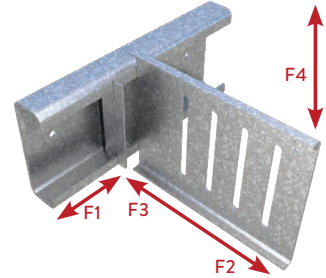

### Drift Rail and Clip - 14ga Clip / 12ga Rail

#### ALLOWABLE DRIFT RAIL CLIP LOADS USING CLIP AS A FIXED CONNECTION

Product code	Stud Mils (Gauge)	Framing Connection		ASD Allowable Loads (lbs)			
		Screw Pattern	No. of Screws	F1 (In-Plane)	F2 (Tension)	F3 (Compression)	F4 (Shear)
DRC3-68	33mils (20ga)	See Figure	(4) x #10	115	490	440	280
	43mils (18ga)		(4) x #10	115	540	520	415
	54mils (16ga)		(4) x #10	115	850	870	740
	68mils (14ga)		(4) x #10	115	850	1170	740
	97mils (12ga)		(4) x #10	115	850	1600	805
DRC6-68	33mils (20ga)	See Figure	(4) x #10	115	490	440	235
	43mils (18ga)		(4) x #10	115	540	520	345
	54mils (16ga)		(4) x #10	115	850	870	705
	68mils (14ga)		(4) x #10	115	850	1170	725
	97mils (12ga)		(4) x #10	115	850	1600	725
DRC8-68	33mils (20ga)	See Figure	(4) x #10	120	490	485	240
	43mils (18ga)		(4) x #10	120	540	620	360
	54mils (16ga)		(4) x #10	120	850	900	725
	68mils (14ga)		(4) x #10	120	850	1105	745
	97mils (12ga)		(4) x #10	120	850	1710	745

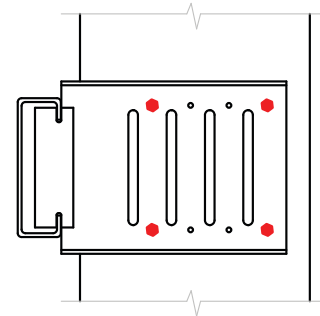

(4) #10 Screw Pattern  
Shown in a DRC6 Clip

#### Notes:

- 1 Allowable loads (ASD) listed are for Drift Rail Clip to stud only (framing connection).
- 2 Drift Rail attachment to structure designed by others. Drift Rail attachment to the structure should occur at every 6" o.c., and each connection capacity should satisfy the design load requirement of the project. Listed Drift Rail clip load capacities must be evaluated along with clip-to-structure connection capacity to establish the governing load capacity of the assembly.
- 3 Allowable loads have not been increased for wind, seismic, or other factors.
- 4 Minimum (4) x #10-16 screws must be used to secure the Drift Rail Clip for attachment to stud.
- 5 It is the responsibility of the designer to properly detail connections on the contract drawings.
- 6 F1 (In-Plane) loads are based on using a Drift Locking Clip (DRLC) or Drift Locking Angle (DRLA) restricting Drift Clip lateral movement.

## Drift Rail and Clip - Structural Attachment Designed by Others

ATTACHMENT TO STRUCTURAL: **DESIGNED BY OTHERS**  
 ATTACHMENT TO STUD: **FIXED CONNECTION W/(8)#10-16**

### Drift Rail and Clip - 12ga Clip / 12ga Rail

#### ALLOWABLE DRIFT RAIL CLIP LOADS USING CLIP AS A FIXED CONNECTION

Clip designation	Stud Mils (Gauge)	Framing Connection		ASD Allowable Loads (lbs)			
		Screw Pattern	No. of Screws	F1 (In-Plane)	F2 (Tension)	F3 (Compression)	F4 (Shear)
DRC6-97	20ga (33mils)	See Figure	(8) x #10	155	560	600	395
	18ga (43mils)		(8) x #10	155	655	670	585
	16ga (54mils)		(8) x #10	155	1000	970	875
	14ga (68mils)		(8) x #10	155	1085	1325	920
	12ga (97mils)		(8) x #10	155	1085	2040	920
DRC8-97	20ga (33mils)	See Figure	(8) x #10	140	560	620	375
	18ga (43mils)		(8) x #10	140	655	730	555
	16ga (54mils)		(8) x #10	140	1000	1060	910
	14ga (68mils)		(8) x #10	140	1085	1340	910
	12ga (97mils)		(8) x #10	140	1085	1965	910

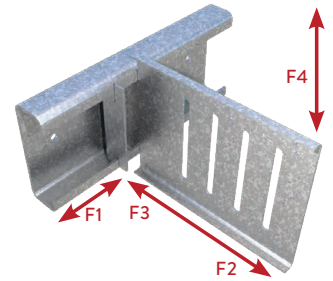

### Drift Rail and Clip - 14ga Clip / 12ga Rail

#### ALLOWABLE DRIFT RAIL CLIP LOADS USING CLIP AS A FIXED CONNECTION

Clip designation	Stud Mils (Gauge)	Framing Connection		ASD Allowable Loads (lbs)			
		Screw Pattern	No. of Screws	F1 (In-Plane)	F2 (Tension)	F3 (Compression)	F4 (Shear)
DRC6-68	20ga (33mils)	See Figure	(8) x #10	115	490	440	395
	18ga (43mils)		(8) x #10	115	540	520	585
	16ga (54mils)		(8) x #10	115	850	870	740
	14ga (68mils)		(8) x #10	115	850	1170	740
	12ga (97mils)		(8) x #10	115	850	1600	805
DRC8-68	20ga (33mils)	See Figure	(8) x #10	120	490	485	375
	18ga (43mils)		(8) x #10	120	540	620	555
	16ga (54mils)		(8) x #10	120	850	900	800
	14ga (68mils)		(8) x #10	120	850	1105	800
	12ga (97mils)		(8) x #10	120	850	1710	865

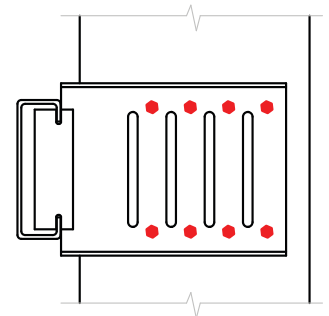

(8) #10 Screw Pattern  
 Shown in a DRC6 Clip

**Notes:**

- 1 Allowable loads (ASD) listed are for Drift Rail Clip to stud only (framing connection).
- 2 Drift Rail attachment to structure designed by others. Drift Rail attachment to the structure should occur at every 6" o.c., and each connection capacity should satisfy the design load requirement of the project. Listed Drift Rail clip load capacities must be evaluated along with clip-to-structure connection capacity to establish the governing load capacity of the assembly.
- 3 Allowable loads have not been increased for wind, seismic, or other factors.
- 4 Minimum (4) x #10-16 screws must be used to secure the Drift Rail Clip for attachment to stud.
- 5 It is the responsibility of the designer to properly detail connections on the contract drawings.
- 6 F1 (In-Plane) loads are based on using a Drift Locking Clip (DRLC) or Drift Locking Angle (DRLA) restricting Drift Clip lateral movement.

## Drift Rail and Clip - Attachment Using (2) #12-24 Fasteners

**ATTACHMENT TO STRUCTURAL STEEL: #12-24 FASTENERS**  
**ATTACHMENT TO STUD: AS A DEFLECTION CONNECTION**

### Drift Rail and Clip - 12ga Clip / 12ga Rail

### ALLOWABLE DRIFT RAIL CLIP LOADS USING CLIP AS A DEFLECTION CONNECTION

Clip designation	Stud Mils (Gauge)	Anchor to structure	Framing Connection		ASD Allowable Loads (lbs)	
			Screw Pattern	No. of Screws	F2 (Tension)	F3 (Compression)
DRC3-97	33mils (20ga)	(2) x #12-24 HWH Fasteners to 3/16" ASTM A36 Steel	See Figure	(2) x #14	560	600
	43mils (18ga)			(2) x #14	655	670
	54mils (16ga)			(2) x #14	1000	970
	68mils (14ga)			(2) x #14	1030	1325
	97mils (12ga)			(2) x #14	1030	2040
DRC6-97	33mils (20ga)	(2) x #12-24 HWH Fasteners to 3/16" ASTM A36 Steel	See Figure	(3) x #14	560	600
	43mils (18ga)			(3) x #14	655	670
	54mils (16ga)			(3) x #14	1000	970
	68mils (14ga)			(3) x #14	1030	1325
	97mils (12ga)			(3) x #14	1030	2040
DRC8-97	33mils (20ga)	(2) x #12-24 HWH Fasteners to 3/16" ASTM A36 Steel	See Figure	(3) x #14	560	620
	43mils (18ga)			(3) x #14	655	730
	54mils (16ga)			(3) x #14	1000	1060
	68mils (14ga)			(3) x #14	1030	1340
	97mils (12ga)			(3) x #14	1030	1965

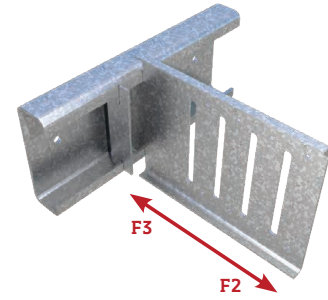

### Drift Rail and Clip - 14ga Clip / 12ga Rail

### ALLOWABLE DRIFT RAIL CLIP LOADS USING CLIP AS A DEFLECTION CONNECTION

Clip designation	Stud Mils (Gauge)	Anchor to structure	Framing Connection		ASD Allowable Loads (lbs)	
			Screw Pattern	No. of Screws	F2 (Tension)	F3 (Compression)
DRC3-68	33mils (20ga)	(2) x #12-24 HWH Fasteners to 3/16" ASTM A36 Steel	See Figure	(2) x #14	490	440
	43mils (18ga)			(2) x #14	540	520
	54mils (16ga)			(2) x #14	850	870
	68mils (14ga)			(2) x #14	850	1170
	97mils (12ga)			(2) x #14	850	1600
DRC6-68	33mils (20ga)	(2) x #12-24 HWH Fasteners to 3/16" ASTM A36 Steel	See Figure	(3) x #14	490	440
	43mils (18ga)			(3) x #14	540	520
	54mils (16ga)			(3) x #14	850	870
	68mils (14ga)			(3) x #14	850	1170
	97mils (12ga)			(3) x #14	850	1600
DRC8-68	33mils (20ga)	(2) x #12-24 HWH Fasteners to 3/16" ASTM A36 Steel	See Figure	(3) x #14	490	485
	43mils (18ga)			(3) x #14	540	620
	54mils (16ga)			(3) x #14	850	900
	68mils (14ga)			(3) x #14	850	1105
	97mils (12ga)			(3) x #14	850	1710

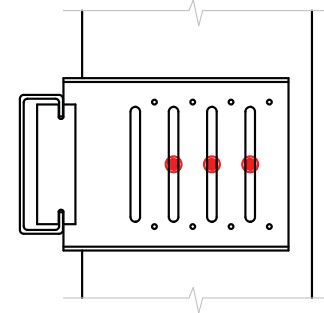

(3) #14 Deflection Screw Pattern Shown in a DRC6 Clip

**Notes:**

- 1 Allowable loads (ASD) listed are for Drift Rail Clip where Drift Rail is attached to 3/16" thick ASTM A36 steel using (2) x #12-24 HWH fasteners spaced 2" apart at 6" on center spacing.
- 2 (2) x #12-24 HWH fasteners must be fastened at every 6" o.c. for Drift Rail attachment to 3/16" ASTM A36 steel structure. Other fasteners may be used to achieve full clip capacity but must be designed separately.
- 3 Allowable loads have not been increased for wind, seismic, or other factors.
- 4 Minimum (2) x #14 shouldered screws (for DRC3) and (3) x #14 shouldered screws (for DRC6 and DRC8) must be used to secure the Drift Rail Clip for attachment to stud (#14 shouldered screws provided with each Drift Rail Clip).
- 5 It is the responsibility of the designer to properly detail connections on the contract drawings.



## Drift Rail and Clip - Attachment Using (2) #12-24 Fasteners

**ATTACHMENT TO STRUCTURAL STEEL: #12-24 FASTENERS**  
**ATTACHMENT TO STUD: FIXED CONNECTION W/(4)#10-16**

### Drift Rail and Clip - 12ga Clip / 12ga Rail

### ALLOWABLE DRIFT RAIL CLIP LOADS USING CLIP AS A FIXED CONNECTION

Clip designation	Stud Mils (Gauge)	Anchor to structure	Framing Connection		ASD Allowable Loads (lbs)			
			Screw Pattern	No. of Screws	F1 (In-Plane)	F2 (Tension)	F3 (Compression)	F4 (Shear)
DRC3-97	33mils (20ga)	(2) x #12-24 HWH Fasteners to 3/16" ASTM A36 Steel	See Figure	(4) x #10	155	560	600	280
	43mils (18ga)			(4) x #10	155	655	670	415
	54mils (16ga)			(4) x #10	155	1000	970	840
	68mils (14ga)			(4) x #10	155	1030	1325	865
	97mils (12ga)			(4) x #10	155	1030	2040	865
DRC6-97	33mils (20ga)	(2) x #12-24 HWH Fasteners to 3/16" ASTM A36 Steel	See Figure	(4) x #10	155	560	600	235
	43mils (18ga)			(4) x #10	155	655	670	345
	54mils (16ga)			(4) x #10	155	1000	970	705
	68mils (14ga)			(4) x #10	155	1030	1325	725
	97mils (12ga)			(4) x #10	155	1030	2040	725
DRC8-97	33mils (20ga)	(2) x #12-24 HWH Fasteners to 3/16" ASTM A36 Steel	See Figure	(4) x #10	140	560	620	240
	43mils (18ga)			(4) x #10	140	655	730	360
	54mils (16ga)			(4) x #10	140	1000	1060	725
	68mils (14ga)			(4) x #10	140	1030	1340	745
	97mils (12ga)			(4) x #10	140	1030	1965	745

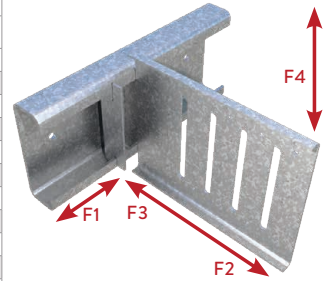

### Drift Rail and Clip - 14ga Clip / 12ga Rail

### ALLOWABLE DRIFT RAIL CLIP LOADS USING CLIP AS A FIXED CONNECTION

Clip designation	Stud Mils (Gauge)	Anchor to structure	Framing Connection		ASD Allowable Loads (lbs)			
			Screw Pattern	No. of Screws	F1 (In-Plane)	F2 (Tension)	F3 (Compression)	F4 (Shear)
DRC3-68	33mils (20ga)	(2) x #12-24 HWH Fasteners to 3/16" ASTM A36 Steel	See Figure	(4) x #10	115	490	440	280
	43mils (18ga)			(4) x #10	115	540	520	415
	54mils (16ga)			(4) x #10	115	850	870	740
	68mils (14ga)			(4) x #10	115	850	1170	740
	97mils (12ga)			(4) x #10	115	850	1600	805
DRC6-68	33mils (20ga)	(2) x #12-24 HWH Fasteners to 3/16" ASTM A36 Steel	See Figure	(4) x #10	115	490	440	235
	43mils (18ga)			(4) x #10	115	540	520	345
	54mils (16ga)			(4) x #10	115	850	870	705
	68mils (14ga)			(4) x #10	115	850	1170	725
	97mils (12ga)			(4) x #10	115	850	1600	725
DRC8-68	33mils (20ga)	(2) x #12-24 HWH Fasteners to 3/16" ASTM A36 Steel	See Figure	(4) x #10	120	490	485	240
	43mils (18ga)			(4) x #10	120	540	620	360
	54mils (16ga)			(4) x #10	120	850	900	725
	68mils (14ga)			(4) x #10	120	850	1105	745
	97mils (12ga)			(4) x #10	120	850	1710	745

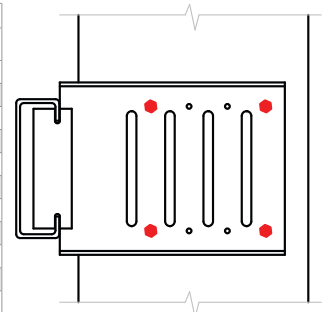

(4) #10 Screw Pattern Shown in a DRC6 Clip

**Notes:**

- 1 Allowable loads (ASD) listed are for Drift Rail Clip where Drift Rail is attached to 3/16" thick ASTM A36 steel using (2) x #12-24 HWH fasteners spaced 2" apart at 6" on center spacing.
- 2 (2) x #12-24 HWH fasteners must be fastened at every 6" o.c. for Drift Rail attachment to 3/16" ASTM A36 steel structure. Other fasteners may be used to achieve full clip capacity but must be designed separately.
- 3 Allowable loads have not been increased for wind, seismic, or other factors.
- 4 Where fasteners are loaded simultaneously, load interaction must be considered following fastener manufacturer guidelines.
- 5 Use linear load interaction for combined loading conditions.
- 6 Minimum (4) x #10-16 screws must be used to secure the Drift Rail Clip for attachment to stud.
- 7 It is the responsibility of the designer to properly detail connections on the contract drawings.
- 8 F1 (In-Plane) loads are based on using a Drift Locking Clip (DRLC) or Drift Locking Angle (DRLA) restricting Drift Clip lateral movement.

## Drift Rail and Clip - Attachment Using (2) #12-24 Fasteners

**ATTACHMENT TO STRUCTURAL STEEL: #12-24 FASTENERS**  
**ATTACHMENT TO STUD: FIXED CONNECTION W/(8)#10-16**

### Drift Rail and Clip - 12ga Clip / 12ga Rail

#### ALLOWABLE DRIFT RAIL CLIP LOADS USING CLIP AS A FIXED CONNECTION

Clip designation	Stud Mils (Gauge)	Anchor to structure	Framing Connection		ASD Allowable Loads (lbs)			
			Screw Pattern	No. of Screws	F1 (In-Plane)	F2 (Tension)	F3 (Compression)	F4 (Shear)
DRC6-97	33mils (20ga)	(2) x #12-24 HWH Fasteners to 3/16" ASTM A36 Steel	See Figure	(8) x #10	155	560	600	395
	43mils (18ga)			(8) x #10	155	655	670	585
	54mils (16ga)			(8) x #10	155	1000	970	875
	68mils (14ga)			(8) x #10	155	1030	1325	920
	97mils (12ga)			(8) x #10	155	1030	2040	920
DRC8-97	33mils (20ga)	(2) x #12-24 HWH Fasteners to 3/16" ASTM A36 Steel	See Figure	(8) x #10	140	560	620	375
	43mils (18ga)			(8) x #10	140	655	730	555
	54mils (16ga)			(8) x #10	140	1000	1060	910
	68mils (14ga)			(8) x #10	140	1030	1340	910
	97mils (12ga)			(8) x #10	140	1030	1965	910

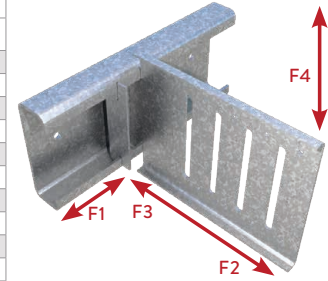

### Drift Rail and Clip - 14ga Clip / 12ga Rail

#### ALLOWABLE DRIFT RAIL CLIP LOADS USING CLIP AS A FIXED CONNECTION

Clip designation	Stud Mils (Gauge)	Anchor to structure	Framing Connection		ASD Allowable Loads (lbs)			
			Screw Pattern	No. of Screws	F1 (In-Plane)	F2 (Tension)	F3 (Compression)	F4 (Shear)
DRC6-68	33mils (20ga)	(2) x #12-24 HWH Fasteners to 3/16" ASTM A36 Steel	See Figure	(8) x #10	115	490	440	395
	43mils (18ga)			(8) x #10	115	540	520	585
	54mils (16ga)			(8) x #10	115	850	870	740
	68mils (14ga)			(8) x #10	115	850	1170	740
	97mils (12ga)			(8) x #10	115	850	1600	805
DRC8-68	33mils (20ga)	(2) x #12-24 HWH Fasteners to 3/16" ASTM A36 Steel	See Figure	(8) x #10	120	490	485	375
	43mils (18ga)			(8) x #10	120	540	620	555
	54mils (16ga)			(8) x #10	120	850	900	800
	68mils (14ga)			(8) x #10	120	850	1105	800
	97mils (12ga)			(8) x #10	120	850	1710	865

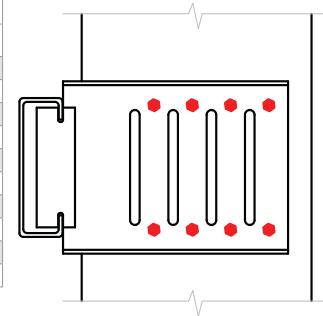

(8) #10 Screw Pattern Shown in a DRC6 Clip

**Notes:**

- 1 Allowable loads (ASD) listed are for Drift Rail Clip where Drift Rail is attached to 3/16" thick ASTM A36 steel using (2) x #12-24 HWH fasteners spaced 2" apart at 6" on center spacing.
- 2 (2) x #12-24 HWH fasteners must be fastened at every 6" o.c. for Drift Rail attachment to 3/16" ASTM A36 steel structure. Other fasteners may be used to achieve full clip capacity but must be designed separately.
- 3 Allowable loads have not been increased for wind, seismic, or other factors.
- 4 Where fasteners are loaded simultaneously, load interaction must be considered following fastener manufacturer guidelines.
- 5 Use linear load interaction for combined loading conditions.
- 6 Minimum (8) x #10-16 screws must be used to secure the Drift Rail Clip for attachment to stud.
- 7 It is the responsibility of the designer to properly detail connections on the contract drawings.
- 8 F1 (In-Plane) loads are based on using a Drift Locking Clip (DRLC) or Drift Locking Angle (DRLA) restricting Drift Clip lateral movement.

## Drift Rail and Clip - Attachment Using (2) Hilti X-U Fasteners

**ATTACHMENT TO STRUCT. STEEL: HILTI X-U FASTENERS**  
**ATTACHMENT TO STUD: AS A DEFLECTION CONNECTION**

### Drift Rail and Clip - 12ga Clip / 12ga Rail

#### ALLOWABLE DRIFT RAIL CLIP LOADS USING CLIP AS A DEFLECTION CONNECTION

Clip designation	Stud Mils (Gauge)	Anchor to structure	Framing Connection		ASD Allowable Loads (lbs)	
			Screw Pattern	No. of Screws	F2 (Tension)	F3 (Compression)
DRC3-97	33mils (20ga)	(2) x Hilti X-U Universal Knurled Shank Fasteners to 3/16" ASTM A36 Steel	See Figure	(2) x #14	560	600
	43mils (18ga)			(2) x #14	655	670
	54mils (16ga)			(2) x #14	1000	970
	68mils (14ga)			(2) x #14	1070	1325
	97mils (12ga)			(2) x #14	1070	2040
DRC6-97	33mils (20ga)	(2) x Hilti X-U Universal Knurled Shank Fasteners to 3/16" ASTM A36 Steel	See Figure	(3) x #14	560	600
	43mils (18ga)			(3) x #14	655	670
	54mils (16ga)			(3) x #14	1000	970
	68mils (14ga)			(3) x #14	1070	1325
	97mils (12ga)			(3) x #14	1070	2040
DRC8-97	33mils (20ga)	(2) x Hilti X-U Universal Knurled Shank Fasteners to 3/16" ASTM A36 Steel	See Figure	(3) x #14	560	620
	43mils (18ga)			(3) x #14	655	730
	54mils (16ga)			(3) x #14	1000	1060
	68mils (14ga)			(3) x #14	1070	1340
	97mils (12ga)			(3) x #14	1070	1965

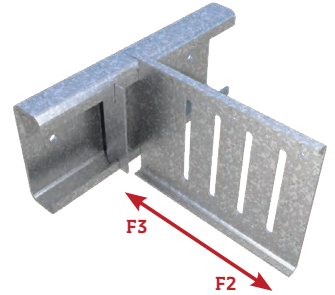

### Drift Rail and Clip - 14ga Clip / 12ga Rail

#### ALLOWABLE DRIFT RAIL CLIP LOADS USING CLIP AS A DEFLECTION CONNECTION

Clip designation	Stud Mils (Gauge)	Anchor to structure	Framing Connection		ASD Allowable Loads (lbs)	
			Screw Pattern	No. of Screws	F2 (Tension)	F3 (Compression)
DRC3-68	33mils (20ga)	(2) x Hilti X-U Universal Knurled Shank Fasteners to 3/16" ASTM A36 Steel	See Figure	(2) x #14	490	440
	43mils (18ga)			(2) x #14	540	520
	54mils (16ga)			(2) x #14	850	870
	68mils (14ga)			(2) x #14	850	1170
	97mils (12ga)			(2) x #14	850	1600
DRC6-68	33mils (20ga)	(2) x Hilti X-U Universal Knurled Shank Fasteners to 3/16" ASTM A36 Steel	See Figure	(3) x #14	490	440
	43mils (18ga)			(3) x #14	540	520
	54mils (16ga)			(3) x #14	850	870
	68mils (14ga)			(3) x #14	850	1170
	97mils (12ga)			(3) x #14	850	1600
DRC8-68	33mils (20ga)	(2) x Hilti X-U Universal Knurled Shank Fasteners to 3/16" ASTM A36 Steel	See Figure	(3) x #14	490	485
	43mils (18ga)			(3) x #14	540	620
	54mils (16ga)			(3) x #14	850	900
	68mils (14ga)			(3) x #14	850	1105
	97mils (12ga)			(3) x #14	850	1710

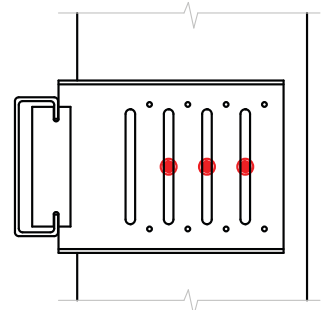

(3) #14 Deflection Screw Pattern  
Shown in a DRC6 Clip

**Notes:**

- 1 Allowable loads (ASD) listed are for Drift Rail Clip where Drift Rail is attached to 3/16" thick ASTM A36 steel using (2) x Hilti X-U Universal Knurled Shank fasteners spaced 2" apart at 6" on center spacing.
- 2 (2) x Hilti X-U Universal Knurled Shank fasteners must be fastened at every 6" o.c. for Drift Rail attachment to 3/16" ASTM A36 steel structure. Other fasteners may be used to achieve full clip capacity but must be designed separately.
- 3 Allowable loads have not been increased for wind, seismic, or other factors.
- 4 Minimum (2) x #14 shouldered screws (for DRC3) and (3) x #14 shouldered screws (for DRC6 and DRC8) must be used to secure the Drift Rail Clip for attachment to stud (#14 shouldered screws provided with each Drift Rail Clip).
- 5 It is the responsibility of the designer to properly detail connections on the contract drawings.

## Drift Rail and Clip - Attachment Using (2) Hilti X-U Fasteners

**ATTACHMENT TO STRUCT. STEEL: HILTI X-U FASTENERS**  
**ATTACHMENT TO STUD: FIXED CONNECTION W/(4)#10-16**

### Drift Rail and Clip - 12ga Clip / 12ga Rail

#### ALLOWABLE DRIFT RAIL CLIP LOADS USING CLIP AS A FIXED CONNECTION

Clip designation	Stud Mils (Gauge)	Anchor to structure	Framing Connection		ASD Allowable Loads (lbs)			
			Screw Pattern	No. of Screws	F1 (In-Plane)	F2 (Tension)	F3 (Compression)	F4 (Shear)
DRC3-97	33mils (20ga)	(2) x Hilti X-U	See Figure	(4) x #10	155	560	600	280
	43mils (18ga)	Universal Knurled		(4) x #10	155	655	670	415
	54mils (16ga)	Shank Fasteners		(4) x #10	155	1000	970	840
	68mils (14ga)	to 3/16" ASTM		(4) x #10	155	1070	1325	865
	97mils (12ga)	A36 Steel		(4) x #10	155	1070	2040	865
DRC6-97	33mils (20ga)	(2) x Hilti X-U	See Figure	(4) x #10	155	560	600	235
	43mils (18ga)	Universal Knurled		(4) x #10	155	655	670	345
	54mils (16ga)	Shank Fasteners		(4) x #10	155	1000	970	705
	68mils (14ga)	to 3/16" ASTM		(4) x #10	155	1070	1325	725
	97mils (12ga)	A36 Steel		(4) x #10	155	1070	2040	725
DRC8-97	33mils (20ga)	(2) x Hilti X-U	See Figure	(4) x #10	140	560	620	240
	43mils (18ga)	Universal Knurled		(4) x #10	140	655	730	360
	54mils (16ga)	Shank Fasteners		(4) x #10	140	1000	1060	725
	68mils (14ga)	to 3/16" ASTM		(4) x #10	140	1070	1340	745
	97mils (12ga)	A36 Steel		(4) x #10	140	1070	1965	745

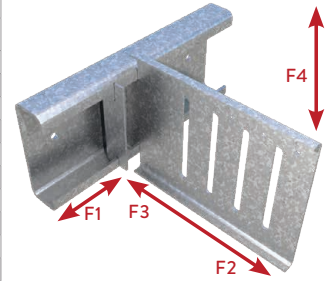

### Drift Rail and Clip - 14ga Clip / 12ga Rail

#### ALLOWABLE DRIFT RAIL CLIP LOADS USING CLIP AS A FIXED CONNECTION

Clip designation	Stud Mils (Gauge)	Anchor to structure	Framing Connection		ASD Allowable Loads (lbs)			
			Screw Pattern	No. of Screws	F1 (In-Plane)	F2 (Tension)	F3 (Compression)	F4 (Shear)
DRC3-68	33mils (20ga)	(2) x Hilti X-U	See Figure	(4) x #10	115	490	440	280
	43mils (18ga)	Universal Knurled		(4) x #10	115	540	520	415
	54mils (16ga)	Shank Fasteners		(4) x #10	115	850	870	740
	68mils (14ga)	to 3/16" ASTM		(4) x #10	115	850	1170	740
	97mils (12ga)	A36 Steel		(4) x #10	115	850	1600	805
DRC6-68	33mils (20ga)	(2) x Hilti X-U	See Figure	(4) x #10	115	490	440	235
	43mils (18ga)	Universal Knurled		(4) x #10	115	540	520	345
	54mils (16ga)	Shank Fasteners		(4) x #10	115	850	870	705
	68mils (14ga)	to 3/16" ASTM		(4) x #10	115	850	1170	725
	97mils (12ga)	A36 Steel		(4) x #10	115	850	1600	725
DRC8-68	33mils (20ga)	(2) x Hilti X-U	See Figure	(4) x #10	120	490	485	240
	43mils (18ga)	Universal Knurled		(4) x #10	120	540	620	360
	54mils (16ga)	Shank Fasteners		(4) x #10	120	850	900	725
	68mils (14ga)	to 3/16" ASTM		(4) x #10	120	850	1105	745
	97mils (12ga)	A36 Steel		(4) x #10	120	850	1710	745

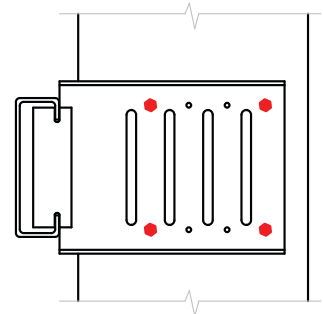

(4) #10 Screw Pattern  
Shown in a DRC6 Clip

**Notes:**

- 1 Allowable loads (ASD) listed are for Drift Rail Clip where Drift Rail is attached to 3/16" thick ASTM A36 steel using (2) x Hilti X-U Universal Knurled Shank fasteners spaced 2" apart at 6" on center spacing.
- 2 (2) x Hilti X-U Universal Knurled Shank fasteners must be fastened at every 6" o.c. for Drift Rail attachment to 3/16" ASTM A36 steel structure. Other fasteners may be used to achieve full clip capacity but must be designed separately.
- 3 Allowable loads have not been increased for wind, seismic, or other factors.
- 4 Where fasteners are loaded simultaneously, load interaction must be considered following fastener manufacturer guidelines.
- 5 Use linear load interaction for combined loading conditions.
- 6 Minimum (4) x #10-16 screws must be used to secure the Drift Rail Clip for attachment to stud.
- 7 It is the responsibility of the designer to properly detail connections on the contract drawings.
- 8 F1 (In-Plane) loads are based on using a Drift Locking Clip (DRLC) or Drift Locking Angle (DRLA) restricting Drift Clip lateral movement.

## Drift Rail and Clip - Attachment Using (2) Hilti X-U Fasteners

**ATTACHMENT TO STRUCT. STEEL: HILTI X-U FASTENERS**  
**ATTACHMENT TO STUD: FIXED CONNECTION W/(8)#10-16**

### Drift Rail and Clip - 12ga Clip / 12ga Rail

#### ALLOWABLE DRIFT RAIL CLIP LOADS USING CLIP AS A FIXED CONNECTION

Clip designation	Stud Mils (Gauge)	Anchor to structure	Framing Connection		ASD Allowable Loads (lbs)			
			Screw Pattern	No. of Screws	F1 (In-Plane)	F2 (Tension)	F3 (Compression)	F4 (Shear)
DRC6-97	33mils (20ga)	(2) x Hilti X-U Universal Knurled Shank Fasteners to 3/16" ASTM A36 Steel	See Figure	(8) x #10	155	560	600	395
	43mils (18ga)			(8) x #10	155	655	670	585
	54mils (16ga)			(8) x #10	155	1000	970	875
	68mils (14ga)			(8) x #10	155	1070	1325	920
	97mils (12ga)			(8) x #10	155	1070	2040	920
DRC8-97	33mils (20ga)	(2) x Hilti X-U Universal Knurled Shank Fasteners to 3/16" ASTM A36 Steel	See Figure	(8) x #10	140	560	620	375
	43mils (18ga)			(8) x #10	140	655	730	555
	54mils (16ga)			(8) x #10	140	1000	1060	910
	68mils (14ga)			(8) x #10	140	1070	1340	910
	97mils (12ga)			(8) x #10	140	1070	1965	910

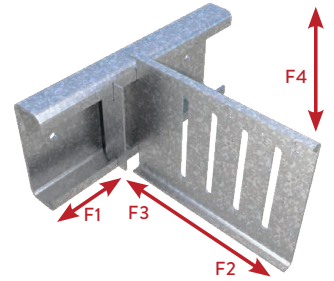

### Drift Rail and Clip - 14ga Clip / 12ga Rail

#### ALLOWABLE DRIFT RAIL CLIP LOADS USING CLIP AS A FIXED CONNECTION

Clip designation	Stud Mils (Gauge)	Anchor to structure	Framing Connection		ASD Allowable Loads (lbs)			
			Screw Pattern	No. of Screws	F1 (In-Plane)	F2 (Tension)	F3 (Compression)	F4 (Shear)
DRC6-68	33mils (20ga)	(2) x Hilti X-U Universal Knurled Shank Fasteners to 3/16" ASTM A36 Steel	See Figure	(8) x #10	115	490	440	395
	43mils (18ga)			(8) x #10	115	540	520	585
	54mils (16ga)			(8) x #10	115	850	870	740
	68mils (14ga)			(8) x #10	115	850	1170	740
	97mils (12ga)			(8) x #10	115	850	1600	805
DRC8-68	33mils (20ga)	(2) x Hilti X-U Universal Knurled Shank Fasteners to 3/16" ASTM A36 Steel	See Figure	(8) x #10	120	490	485	375
	43mils (18ga)			(8) x #10	120	540	620	555
	54mils (16ga)			(8) x #10	120	850	900	800
	68mils (14ga)			(8) x #10	120	850	1105	800
	97mils (12ga)			(8) x #10	120	850	1710	865

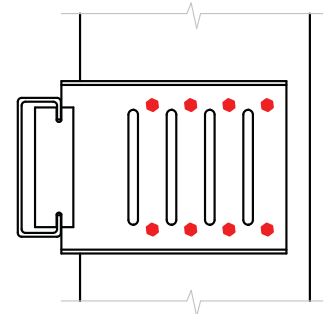

(8) #10 Screw Pattern Shown in a DRC6 Clip

**Notes:**

- 1 Allowable loads (ASD) listed are for Drift Rail Clip where Drift Rail is attached to 3/16" thick ASTM A36 steel using (2) x Hilti X-U Universal Knurled Shank fasteners spaced 2" apart at 6" on center spacing.
- 2 (2) x Hilti X-U Universal Knurled Shank fasteners must be fastened at every 6" o.c. for Drift Rail attachment to 3/16" ASTM A36 steel structure. Other fasteners may be used to achieve full clip capacity but must be designed separately.
- 3 Allowable loads have not been increased for wind, seismic, or other factors.
- 4 Where fasteners are loaded simultaneously, load interaction must be considered following fastener manufacturer guidelines.
- 5 Use linear load interaction for combined loading conditions.
- 6 Minimum (8) x #10-16 screws must be used to secure the Drift Rail Clip for attachment to stud.
- 7 It is the responsibility of the designer to properly detail connections on the contract drawings.
- 8 F1 (In-Plane) loads are based on using a Drift Locking Clip (DRLC) or Drift Locking Angle (DRLA) restricting Drift Clip lateral movement.

## Drift Rail and Clip - Attachment Using (1) 1/4" Hilti KWIK HUS-EZ

**ATTACHMENT TO CONCRETE: 1/4" HILTI KWIK HUS-EZ**  
**ATTACHMENT TO STUD: AS A DEFLECTION CONNECTION**

### Drift Rail and Clip - 12ga Clip / 12ga Rail

#### ALLOWABLE DRIFT RAIL CLIP LOADS USING CLIP AS A DEFLECTION CONNECTION

Clip designation	Stud Mils (Gauge)	Anchor to structure	Framing Connection		ASD Allowable Loads (lbs)	
			Screw Pattern	No. of Screws	F2 (Tension)	F3 (Compression)
DRC3-97	33mils (20ga)	(1) x 1/4" Hilti KWIK HUS-EZ @ 6" o.c. (3000psi uncracked concrete)	See Figure	(2) x #14	560	600
	43mils (18ga)			(2) x #14	655	670
	54mils (16ga)			(2) x #14	1000	970
	68mils (14ga)			(2) x #14	1045	1325
	97mils (12ga)			(2) x #14	1045	2040
DRC6-97	33mils (20ga)	(1) x 1/4" Hilti KWIK HUS-EZ @ 6" o.c. (3000psi uncracked concrete)	See Figure	(3) x #14	560	600
	43mils (18ga)			(3) x #14	655	670
	54mils (16ga)			(3) x #14	1000	970
	68mils (14ga)			(3) x #14	1045	1325
	97mils (12ga)			(3) x #14	1045	2040
DRC8-97	33mils (20ga)	(1) x 1/4" Hilti KWIK HUS-EZ @ 6" o.c. (3000psi uncracked concrete)	See Figure	(3) x #14	560	620
	43mils (18ga)			(3) x #14	655	730
	54mils (16ga)			(3) x #14	1000	1060
	68mils (14ga)			(3) x #14	1045	1340
	97mils (12ga)			(3) x #14	1045	1965

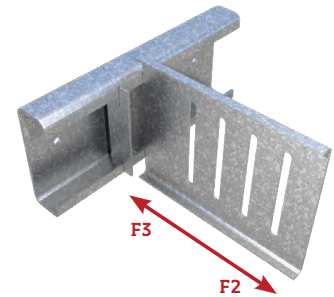

### Drift Rail and Clip - 14ga Clip / 12ga Rail

#### ALLOWABLE DRIFT RAIL CLIP LOADS USING CLIP AS A DEFLECTION CONNECTION

Clip designation	Stud Mils (Gauge)	Anchor to structure	Framing Connection		ASD Allowable Loads (lbs)	
			Screw Pattern	No. of Screws	F2 (Tension)	F3 (Compression)
DRC3-68	33mils (20ga)	(1) x 1/4" Hilti KWIK HUS-EZ @ 6" o.c. (3000psi uncracked concrete)	See Figure	(2) x #14	490	440
	43mils (18ga)			(2) x #14	540	520
	54mils (16ga)			(2) x #14	850	870
	68mils (14ga)			(2) x #14	850	1170
	97mils (12ga)			(2) x #14	850	1600
DRC6-68	33mils (20ga)	(1) x 1/4" Hilti KWIK HUS-EZ @ 6" o.c. (3000psi uncracked concrete)	See Figure	(3) x #14	490	440
	43mils (18ga)			(3) x #14	540	520
	54mils (16ga)			(3) x #14	850	870
	68mils (14ga)			(3) x #14	850	1170
	97mils (12ga)			(3) x #14	850	1600
DRC8-68	33mils (20ga)	(1) x 1/4" Hilti KWIK HUS-EZ @ 6" o.c. (3000psi uncracked concrete)	See Figure	(3) x #14	490	485
	43mils (18ga)			(3) x #14	540	620
	54mils (16ga)			(3) x #14	850	900
	68mils (14ga)			(3) x #14	850	1105
	97mils (12ga)			(3) x #14	850	1710

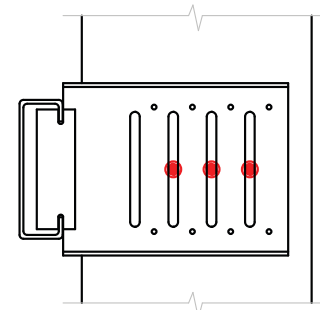

(3) #14 Deflection Screw Pattern  
Shown in a DRC6 Clip

**Notes:**

- 1 Allowable loads (ASD) listed are for Drift Rail Clip where Drift Rail is attached to 3000psi uncracked concrete using (1) x 1/4" Hilti X KWIK HUS-EZ anchor only.
- 2 (1) x 1/4" Hilti KWIK HUS-EZ anchors (nom. embedment depth of 2-1/2", 3000psi uncracked concrete) should be fastened at every 6" o.c. for Drift Rail attachment to structure. Other anchors may be used to achieve full clip capacity but must be designed separately.
- 3 Allowable loads have not been increased for wind, seismic, or other factors.
- 4 Minimum (2) x #14 shouldered screws (for DRC3) and (3) x #14 shouldered screws (for DRC6 and DRC8) must be used to secure the Drift Rail Clip for attachment to stud (#14 shouldered screws provided with each Drift Rail Clip).
- 5 It is the responsibility of the designer to properly detail connections on the contract drawings.

## Drift Rail and Clip - Attachment Using (1) 1/4" Hilti KWIK HUS-EZ

**ATTACHMENT TO CONCRETE: 1/4" HILTI KWIK HUS-EZ**  
**ATTACHMENT TO STUD: FIXED CONNECTION W/(4)#10-16**

### Drift Rail and Clip - 12ga Clip / 12ga Rail

### ALLOWABLE DRIFT RAIL CLIP LOADS USING CLIP AS A FIXED CONNECTION

Clip designation	Stud Mils (Gauge)	Anchor to structure	Framing Connection		ASD Allowable Loads (lbs)			
			Screw Pattern	No. of Screws	F1 (In-Plane)	F2 (Tension)	F3 (Compression)	F4 (Shear)
DRC3-97	33mils (20ga)	(1) x 1/4" Hilti KWIK HUS-EZ @ 6" o.c. (3000psi uncracked concrete)	See Figure	(4) x #10	155	560	600	280
	43mils (18ga)			(4) x #10	155	655	670	415
	54mils (16ga)			(4) x #10	155	1000	970	840
	68mils (14ga)			(4) x #10	155	1045	1325	865
	97mils (12ga)			(4) x #10	155	1045	2040	865
DRC6-97	33mils (20ga)	(1) x 1/4" Hilti KWIK HUS-EZ @ 6" o.c. (3000psi uncracked concrete)	See Figure	(4) x #10	155	560	600	235
	43mils (18ga)			(4) x #10	155	655	670	345
	54mils (16ga)			(4) x #10	155	1000	970	705
	68mils (14ga)			(4) x #10	155	1045	1325	725
	97mils (12ga)			(4) x #10	155	1045	2040	725
DRC8-97	33mils (20ga)	(1) x 1/4" Hilti KWIK HUS-EZ @ 6" o.c. (3000psi uncracked concrete)	See Figure	(4) x #10	140	560	620	240
	43mils (18ga)			(4) x #10	140	655	730	360
	54mils (16ga)			(4) x #10	140	1000	1060	725
	68mils (14ga)			(4) x #10	140	1045	1340	745
	97mils (12ga)			(4) x #10	140	1045	1965	745

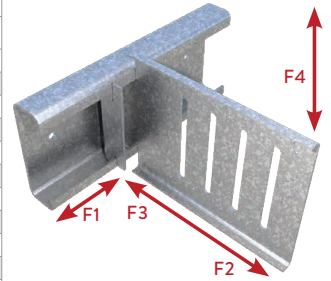

### Drift Rail and Clip - 14ga Clip / 12ga Rail

### ALLOWABLE DRIFT RAIL CLIP LOADS USING CLIP AS A FIXED CONNECTION

Clip designation	Stud Mils (Gauge)	Anchor to structure	Framing Connection		ASD Allowable Loads (lbs)			
			Screw Pattern	No. of Screws	F1 (In-Plane)	F2 (Tension)	F3 (Compression)	F4 (Shear)
DRC3-68	33mils (20ga)	(1) x 1/4" Hilti KWIK HUS-EZ @ 6" o.c. (3000psi uncracked concrete)	See Figure	(4) x #10	115	490	440	280
	43mils (18ga)			(4) x #10	115	540	520	415
	54mils (16ga)			(4) x #10	115	850	870	740
	68mils (14ga)			(4) x #10	115	850	1170	740
	97mils (12ga)			(4) x #10	115	850	1600	805
DRC6-68	33mils (20ga)	(1) x 1/4" Hilti KWIK HUS-EZ @ 6" o.c. (3000psi uncracked concrete)	See Figure	(4) x #10	115	490	440	235
	43mils (18ga)			(4) x #10	115	540	520	345
	54mils (16ga)			(4) x #10	115	850	870	705
	68mils (14ga)			(4) x #10	115	850	1170	725
	97mils (12ga)			(4) x #10	115	850	1600	725
DRC8-68	33mils (20ga)	(1) x 1/4" Hilti KWIK HUS-EZ @ 6" o.c. (3000psi uncracked concrete)	See Figure	(4) x #10	120	490	485	240
	43mils (18ga)			(4) x #10	120	540	620	360
	54mils (16ga)			(4) x #10	120	850	900	725
	68mils (14ga)			(4) x #10	120	850	1105	745
	97mils (12ga)			(4) x #10	120	850	1710	745

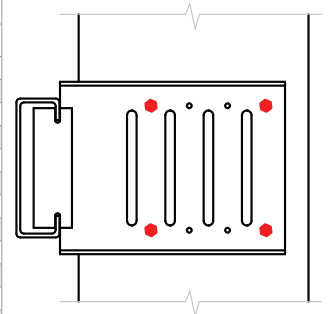

**Notes:**

- 1 Allowable loads (ASD) listed are for Drift Rail Clip where Drift Rail is attached to 3000psi uncracked concrete using (1) x 1/4" Hilti KWIK HUS-EZ anchor only.
- 2 (1) x 1/4" Hilti KWIK HUS-EZ anchors (nom. embedment depth of 2-1/2", 3000psi uncracked concrete) should be fastened at every 6" o.c. for Drift Rail attachment to structure. Other anchors may be used to achieve full clip capacity but must be designed separately.
- 3 Allowable loads have not been increased for wind, seismic, or other factors.
- 4 Where anchors are loaded simultaneously, load interaction must be considered following anchor manufacturer guidelines.
- 5 Use linear load interaction for combined loading conditions.
- 6 Minimum (4) x #10-16 screws must be used to secure the Drift Rail Clip for attachment to stud.
- 7 It is the responsibility of the designer to properly detail connections on the contract drawings.
- 8 F1 (In-Plane) loads are based on using a Drift Locking Clip (DRLC) or Drift Locking Angle (DRLA) restricting Drift Clip lateral movement.

## Drift Rail and Clip - Attachment Using (1) 1/4" Hilti KWIK HUS-EZ

**ATTACHMENT TO CONCRETE: 1/4" HILTI KWIK HUS-EZ**  
**ATTACHMENT TO STUD: FIXED CONNECTION W/(8)#10-16**

### Drift Rail and Clip - 12ga Clip / 12ga Rail

#### ALLOWABLE DRIFT RAIL CLIP LOADS USING CLIP AS A FIXED CONNECTION

Clip designation	Stud Mils (Gauge)	Anchor to structure	Framing Connection		ASD Allowable Loads (lbs)			
			Screw Pattern	No. of Screws	F1 (In-Plane)	F2 (Tension)	F3 (Compression)	F4 (Shear)
DRC6-97	33mils (20ga)	(1) x 1/4" Hilti KWIK HUS-EZ @ 6" o.c. (3000psi uncracked concrete)	See Figure	(8) x #10	155	560	600	395
	43mils (18ga)			(8) x #10	155	655	670	585
	54mils (16ga)			(8) x #10	155	1000	970	875
	68mils (14ga)			(8) x #10	155	1045	1325	920
	97mils (12ga)			(8) x #10	155	1045	2040	920
DRC8-97	33mils (20ga)	(1) x 1/4" Hilti KWIK HUS-EZ @ 6" o.c. (3000psi uncracked concrete)	See Figure	(8) x #10	140	560	620	375
	43mils (18ga)			(8) x #10	140	655	730	555
	54mils (16ga)			(8) x #10	140	1000	1060	910
	68mils (14ga)			(8) x #10	140	1045	1340	910
	97mils (12ga)			(8) x #10	140	1045	1965	910

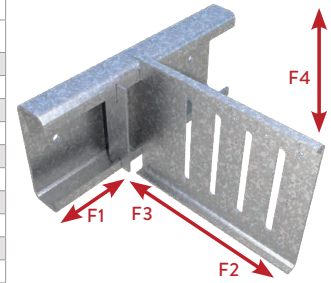

### Drift Rail and Clip - 14ga Clip / 12ga Rail

#### ALLOWABLE DRIFT RAIL CLIP LOADS USING CLIP AS A FIXED CONNECTION

Clip designation	Stud Mils (Gauge)	Anchor to structure	Framing Connection		ASD Allowable Loads (lbs)			
			Screw Pattern	No. of Screws	F1 (In-Plane)	F2 (Tension)	F3 (Compression)	F4 (Shear)
DRC6-68	33mils (20ga)	(1) x 1/4" Hilti KWIK HUS-EZ @ 6" o.c. (3000psi uncracked concrete)	See Figure	(8) x #10	115	490	440	395
	43mils (18ga)			(8) x #10	115	540	520	585
	54mils (16ga)			(8) x #10	115	850	870	740
	68mils (14ga)			(8) x #10	115	850	1170	740
	97mils (12ga)			(8) x #10	115	850	1600	805
DRC8-68	33mils (20ga)	(1) x 1/4" Hilti KWIK HUS-EZ @ 6" o.c. (3000psi uncracked concrete)	See Figure	(8) x #10	120	490	485	375
	43mils (18ga)			(8) x #10	120	540	620	555
	54mils (16ga)			(8) x #10	120	850	900	800
	68mils (14ga)			(8) x #10	120	850	1105	800
	97mils (12ga)			(8) x #10	120	850	1710	865

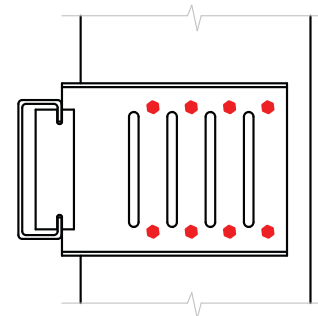

(8) #10 Screw Pattern  
Shown in a DRC6 Clip

**Notes:**

- 1 Allowable loads (ASD) listed are for Drift Rail Clip where Drift Rail is attached to 3000psi uncracked concrete using (1) x 1/4" Hilti KWIK HUS-EZ anchor only.
- 2 (1) x 1/4" Hilti KWIK HUS-EZ anchors (nom. embedment depth of 2-1/2", 3000psi uncracked concrete) should be fastened at every 6" o.c. for Drift Rail attachment to structure. Other anchors may be used to achieve full clip capacity but must be designed separately.
- 3 Allowable loads have not been increased for wind, seismic, or other factors.
- 4 Where anchors are loaded simultaneously, load interaction must be considered following anchor manufacturer guidelines.
- 5 Use linear load interaction for combined loading conditions.
- 6 Minimum (8) x #10-16 screws must be used to secure the Drift Rail Clip for attachment to stud.
- 7 It is the responsibility of the designer to properly detail connections on the contract drawings.
- 8 F1 (In-Plane) loads are based on using a Drift Locking Clip (DRLC) or Drift Locking Angle (DRLA) restricting Drift Clip lateral movement.



## Drift Headed Rail and Clip - Cast In Place

ATTACHMENT TO STRUCTURE: **CAST IN PLACE**  
 ATTACHMENT TO STUD: **AS A DEFLECTION CONNECTION**

### Drift Headed Rail and Clip - 12ga Clip / 12ga Rail

#### ALLOWABLE DRIFT RAIL CLIP LOADS USING CLIP AS A DEFLECTION CONNECTION

Clip designation	Stud Mils (Gauge)	Framing Connection		ASD Allowable Loads (lbs)	
		Screw Pattern	No. of Screws	F2 (Tension)	F3 (Compression)
DRC3-97	33mils (20ga)	See Figure	(2) x #14	560	600
	43mils (18ga)		(2) x #14	655	670
	54mils (16ga)		(2) x #14	1000	970
	68mils (14ga)		(2) x #14	1085	1325
	97mils (12ga)		(2) x #14	1085	2040
DRC6-97	33mils (20ga)	See Figure	(3) x #14	560	600
	43mils (18ga)		(3) x #14	655	670
	54mils (16ga)		(3) x #14	1000	970
	68mils (14ga)		(3) x #14	1085	1325
	97mils (12ga)		(3) x #14	1085	2040
DRC8-97	33mils (20ga)	See Figure	(3) x #14	560	620
	43mils (18ga)		(3) x #14	655	730
	54mils (16ga)		(3) x #14	1000	1060
	68mils (14ga)		(3) x #14	1085	1340
	97mils (12ga)		(3) x #14	1085	1965

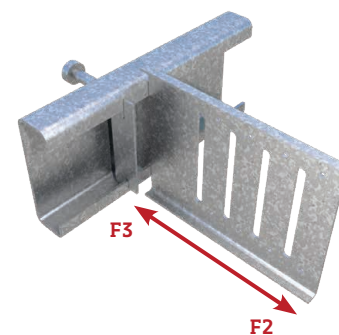

### Drift Headed Rail and Clip - 14ga Clip / 12ga Rail

#### ALLOWABLE DRIFT RAIL CLIP LOADS USING CLIP AS A DEFLECTION CONNECTION

Clip designation	Stud Mils (Gauge)	Framing Connection		ASD Allowable Loads (lbs)	
		Screw Pattern	No. of Screws	F2 (Tension)	F3 (Compression)
DRC3-68	33mils (20ga)	See Figure	(2) x #14	490	440
	43mils (18ga)		(2) x #14	540	520
	54mils (16ga)		(2) x #14	850	870
	68mils (14ga)		(2) x #14	850	1170
	97mils (12ga)		(2) x #14	850	1600
DRC6-68	33mils (20ga)	See Figure	(3) x #14	490	440
	43mils (18ga)		(3) x #14	540	520
	54mils (16ga)		(3) x #14	850	870
	68mils (14ga)		(3) x #14	850	1170
	97mils (12ga)		(3) x #14	850	1600
DRC8-68	33mils (20ga)	See Figure	(3) x #14	490	485
	43mils (18ga)		(3) x #14	540	620
	54mils (16ga)		(3) x #14	850	900
	68mils (14ga)		(3) x #14	850	1105
	97mils (12ga)		(3) x #14	850	1710

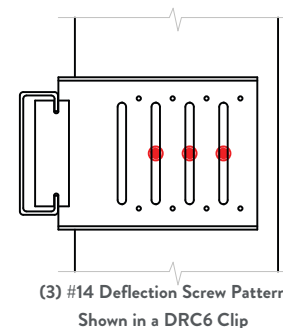

**Notes:**

- 1 Allowable loads (ASD) listed are for Drift Rail Clip to stud only (framing connection).
- 2 Maximum tension on DHR-97 anchor should not exceed 1,600 lbs ASD. In tension and shear, the strength of the DHR-97 anchor itself should be considered. The weld does not need to be considered in tension or shear as the load table and 1,600 lbs ASD tension maximum are inclusive of the strength of the welds. Designers must check Drift Headed Rail (DHR-97) tension and shear anchorage capacity in concrete per ACI 318 based on actual edge distance and concrete compressive strength.
- 3 Allowable loads have not been increased for wind, seismic, or other factors.
- 4 Minimum (2) x #14 shouldered screws (for DRC3) and (3) x #14 shouldered screws (for DRC6 and DRC8) must be used to secure the Drift Rail Clip for attachment to stud (#14 shouldered screws provided with each Drift Rail Clip).
- 5 It is the responsibility of the designer to properly detail connections on the contract drawings.

## Drift Headed Rail and Clip - Cast In Place

ATTACHMENT TO STRUCTURE: **CAST IN PLACE**

ATTACHMENT TO STUD: **FIXED CONNECTION W/(4)#10-16**

### Drift Headed Rail and Clip - 12ga Clip / 12ga Rail

#### ALLOWABLE DRIFT RAIL CLIP LOADS USING CLIP AS A FIXED CONNECTION

Clip designation	Stud gauge (mils)	Framing Connection		ASD Allowable Loads (lbs)			
		Screw Pattern	No. of Screws	F1 (In-Plane)	F2 (Tension)	F3 (Compression)	F4 (Shear)
DRC3-97	20ga (33mils)	See Figure	(4) x #10	155	560	600	280
	18ga (43mils)		(4) x #10	155	655	670	415
	16ga (54mils)		(4) x #10	155	1000	970	840
	14ga (68mils)		(4) x #10	155	1085	1325	865
	12ga (97mils)		(4) x #10	155	1085	2040	865
DRC6-97	20ga (33mils)	See Figure	(4) x #10	155	560	600	235
	18ga (43mils)		(4) x #10	155	655	670	345
	16ga (54mils)		(4) x #10	155	1000	970	705
	14ga (68mils)		(4) x #10	155	1085	1325	725
	12ga (97mils)		(4) x #10	155	1085	2040	725
DRC8-97	20ga (33mils)	See Figure	(4) x #10	140	560	620	240
	18ga (43mils)		(4) x #10	140	655	730	360
	16ga (54mils)		(4) x #10	140	1000	1060	725
	14ga (68mils)		(4) x #10	140	1085	1340	745
	12ga (97mils)		(4) x #10	140	1085	1965	745

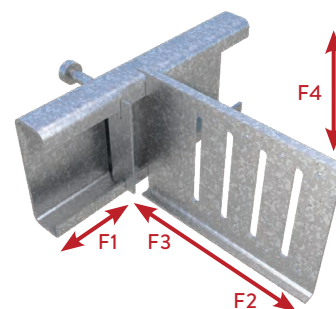

### Drift Headed Rail and Clip - 14ga Clip / 12ga Rail

#### ALLOWABLE DRIFT RAIL CLIP LOADS USING CLIP AS A FIXED CONNECTION

Clip designation	Stud gauge (mils)	Framing Connection		ASD Allowable Loads (lbs)			
		Screw Pattern	No. of Screws	F1 (In-Plane)	F2 (Tension)	F3 (Compression)	F4 (Shear)
DRC3-68	20ga (33mils)	See Figure	(4) x #10	115	490	440	280
	18ga (43mils)		(4) x #10	115	540	520	415
	16ga (54mils)		(4) x #10	115	850	870	740
	14ga (68mils)		(4) x #10	115	850	1170	740
	12ga (97mils)		(4) x #10	115	850	1600	805
DRC6-68	20ga (33mils)	See Figure	(4) x #10	115	490	440	235
	18ga (43mils)		(4) x #10	115	540	520	345
	16ga (54mils)		(4) x #10	115	850	870	705
	14ga (68mils)		(4) x #10	115	850	1170	725
	12ga (97mils)		(4) x #10	115	850	1600	725
DRC8-68	20ga (33mils)	See Figure	(4) x #10	120	490	485	240
	18ga (43mils)		(4) x #10	120	540	620	360
	16ga (54mils)		(4) x #10	120	850	900	725
	14ga (68mils)		(4) x #10	120	850	1105	745
	12ga (97mils)		(4) x #10	120	850	1710	745

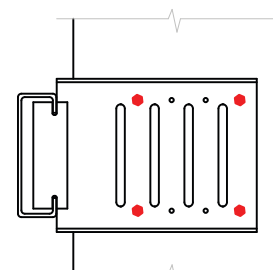

(4) #10 Screw Pattern  
Shown in a DRC6 Clip

#### Notes:

- 1 Allowable loads (ASD) listed are for Drift Rail Clip to stud only (framing connection).
- 2 Maximum tension on DHR-97 anchor should not exceed 1,600 lbs ASD. In tension and shear, the strength of the DHR-97 anchor itself should be considered. The weld does not need to be considered in tension or shear as the load table and 1,600 lbs ASD tension maximum are inclusive of the strength of the welds. Designers must check Drift Headed Rail (DHR-97) tension and shear anchorage capacity in concrete per ACI 318 based on actual edge distance and concrete compressive strength.
- 3 Allowable loads have not been increased for wind, seismic, or other factors.
- 4 Minimum (4) x #10-16 screws must be used to secure the Drift Rail Clip for attachment to stud.
- 5 It is the responsibility of the designer to properly detail connections on the contract drawings.
- 6 F1 (In-Plane) loads are based on using a Drift Locking Clip (DRLC) or Drift Locking Angle (DRLA) restricting Drift Clip lateral movement.

## Drift Headed Rail and Clip - Cast In Place

ATTACHMENT TO STRUCTURE: **CAST IN PLACE**  
 ATTACHMENT TO STUD: **FIXED CONNECTION W/(8)#10-16**

### Drift Headed Rail and Clip - 12ga Clip / 12ga Rail

#### ALLOWABLE DRIFT RAIL CLIP LOADS USING CLIP AS A FIXED CONNECTION

Clip designation	Stud gauge (mils)	Framing Connection		ASD Allowable Loads (lbs)			
		Screw Pattern	No. of Screws	F1 (In-Plane)	F2 (Tension)	F3 (Compression)	F4 (Shear)
DRC6-97	20ga (33mils)	See Figure	(8) x #10	155	560	600	395
	18ga (43mils)		(8) x #10	155	655	670	585
	16ga (54mils)		(8) x #10	155	1000	970	875
	14ga (68mils)		(8) x #10	155	1085	1325	920
	12ga (97mils)		(8) x #10	155	1085	2040	920
DRC8-97	20ga (33mils)	See Figure	(8) x #10	140	560	620	375
	18ga (43mils)		(8) x #10	140	655	730	555
	16ga (54mils)		(8) x #10	140	1000	1060	910
	14ga (68mils)		(8) x #10	140	1085	1340	910
	12ga (97mils)		(8) x #10	140	1085	1965	910

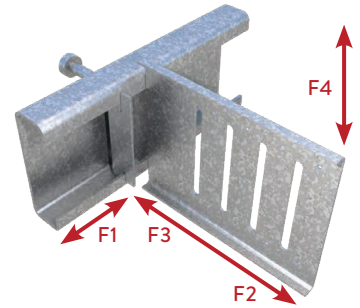

### Drift Headed Rail and Clip - 14ga Clip / 12ga Rail

#### ALLOWABLE DRIFT RAIL CLIP LOADS USING CLIP AS A FIXED CONNECTION

Clip designation	Stud gauge (mils)	Framing Connection		ASD Allowable Loads (lbs)			
		Screw Pattern	No. of Screws	F1 (In-Plane)	F2 (Tension)	F3 (Compression)	F4 (Shear)
DRC6-68	20ga (33mils)	See Figure	(8) x #10	115	490	440	395
	18ga (43mils)		(8) x #10	115	540	520	585
	16ga (54mils)		(8) x #10	115	850	870	740
	14ga (68mils)		(8) x #10	115	850	1170	740
	12ga (97mils)		(8) x #10	115	850	1600	805
DRC8-68	20ga (33mils)	See Figure	(8) x #10	120	490	485	375
	18ga (43mils)		(8) x #10	120	540	620	555
	16ga (54mils)		(8) x #10	120	850	900	800
	14ga (68mils)		(8) x #10	120	850	1105	800
	12ga (97mils)		(8) x #10	120	850	1710	865

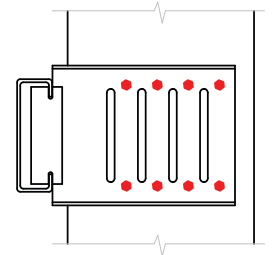

(8) #10 Screw Pattern Shown in a DRC6 Clip

**Notes:**

- 1 Allowable loads (ASD) listed are for Drift Rail Clip to stud only (framing connection).
- 2 Maximum tension on DHR-97 anchor should not exceed 1,600 lbs ASD. In tension and shear, the strength of the DHR-97 anchor itself should be considered. The weld does not need to be considered in tension or shear as the load table and 1,600 lbs ASD tension maximum are inclusive of the strength of the welds. Designers must check Drift Headed Rail (DHR-97) tension and shear anchorage capacity in concrete per ACI 318 based on actual edge distance and concrete compressive strength.
- 3 Allowable loads have not been increased for wind, seismic, or other factors.
- 4 Minimum (4) x #10-16 screws must be used to secure the Drift Rail Clip for attachment to stud.
- 5 It is the responsibility of the designer to properly detail connections on the contract drawings.
- 6 F1 (In-Plane) loads are based on using a Drift Locking Clip (DRLC) or Drift Locking Angle (DRLA) restricting Drift Clip lateral movement.

Product Detail



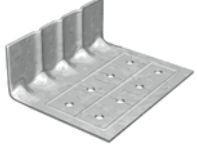
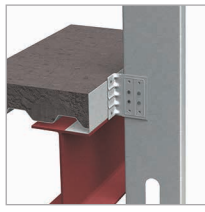

**1 Uni-Clip™ End Clip**  
pages 74-75

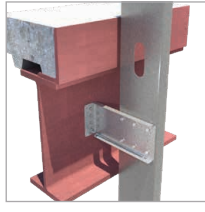

**2 Extended Uni-Clip™**  
pages 76-77

**3 Extended Uni-Clip™ with Anchor Holes**  
pages 78-79

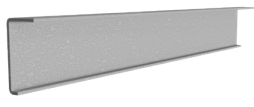

**4 Extended SwiftClip™ LE-Series™**  
page 88

**5 SwiftClip™ L-Series™ Support Clip**  
pages 86-87

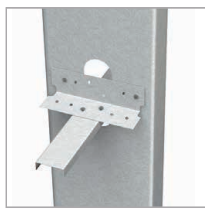

**6 EasyClip U-Series™ Clip Angle**  
page 89

**7 FastBridge™ Clip**  
pages 96-97

**8 H-Series™ Universal Header Hanger**  
pages 98-99

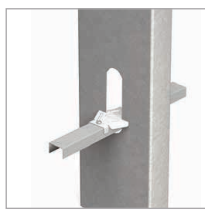
**9 EasyClip S-Series™ Support Clip**  
pages 90-91

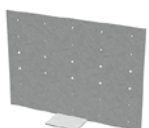

**10 HDSC Header Bracket**  
pages 172-175



**11 Header Cripple Stud Clip**  
page 184



**12 EasyClip™ A-Series™ End Clip**  
pages 92-93



**13 ClarkDietrich Holdown and Holdown Plate**  
pages 100-107



**14 EasyClip D- and T-Series™ Anchor Clips**  
pages 94-95





**15 ClarkDietrich Moment Clip**  
pages 108-109



**16 ClarkDietrich Pony Wall (Heavy & Lite)**  
pages 110-117



**17 Universal Bypass Clip**  
pages 80-85



## Uni-Clip™ End Clip

For numerous rigid framing connections and conditions, including two-axis loading, shear and tension.

ClarkDietrich's Uni-Clip™ end clip is a universal framing clip used to attach and support numerous rigid framing conditions. The Uni-Clip framing clip has a stiffened corner that provides superior design values. Embossed fastening patterns ensure easy, accurate placement of screws or powder-actuated fasteners. Designed to transfer large horizontal and vertical loads, this clip is ideal for most rigid connections, including shear, tension and two-axis loading.

### ALTERNATIVE PRODUCTS

- EasyClip™ D-Series™ Anchor Clip
- EasyClip T-Series™ Tall Anchor Clip
- EasyClip E-Series™ Support Clip
- Universal Bypass Clip

### PRODUCT DIMENSIONS

3-1/2" x 1-1/2" x 4-1/2"

### MATERIAL SPECIFICATIONS

- Gauge:** 14 gauge (68mils)
- Design Thickness:** 0.0713 inches
- Coating:** G90
- Yield Strength:** 50ksi
- ASTM:** A653/A653M

### INSTALLATION

Uni-Clip end clips are attached to cold-formed steel framing members using #10 minimum self-drilling screws driven through the clip holes into the steel framing. Follow the required fastener and anchor placement patterns to achieve the allowable load. Connections to the primary building frame can be made with powder-actuated fasteners, screws or welds per design requirement.

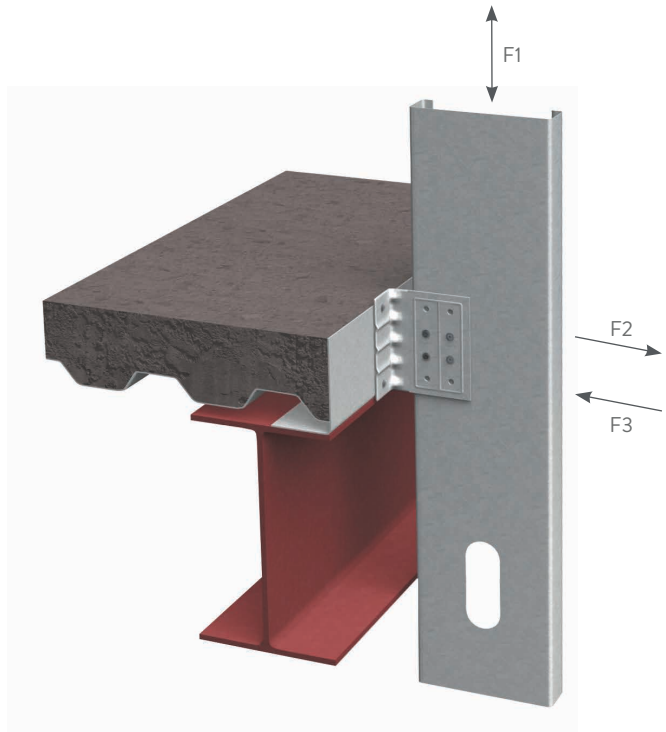
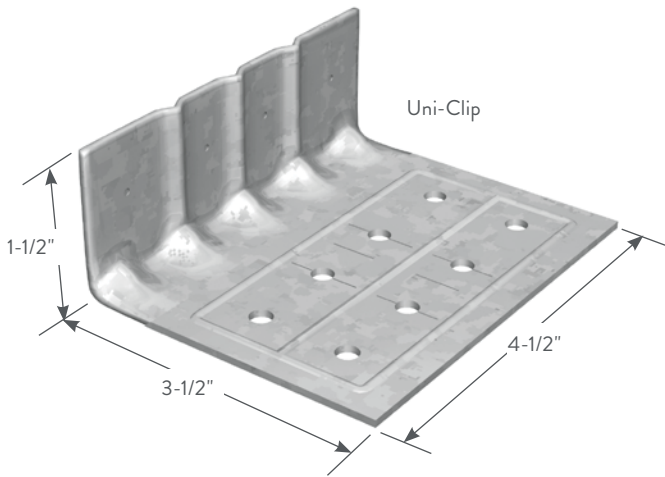

### Uni-Clip™ End Clip (UCEC)

Product code	Thickness		Size (in)	Packaging Pcs./Carton
	Mils (Gauge)	Design thickness (in)		
UCEC	68mils (14ga)	0.0713	3-1/2 x 1-1/2 x 4-1/2	25

U.S. Patent No. 6,688,069

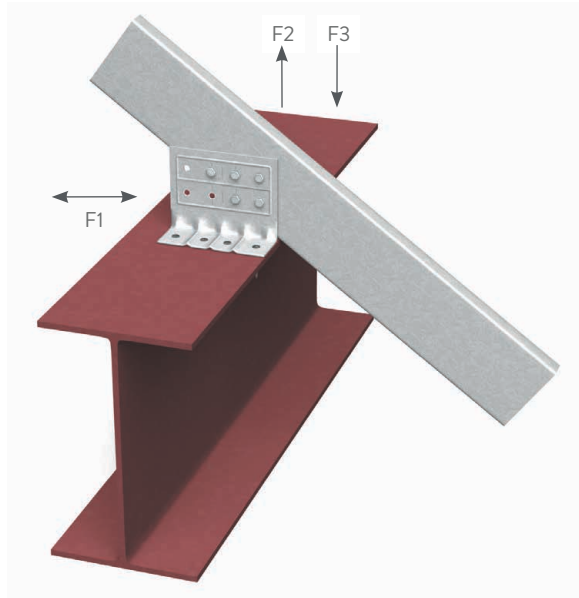

Location Options with (4) Screws

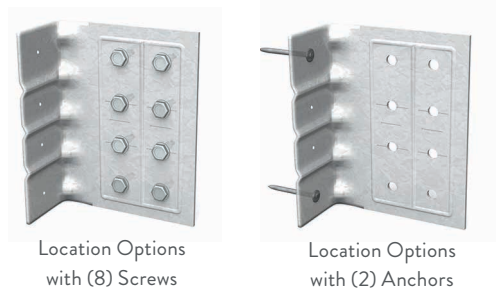
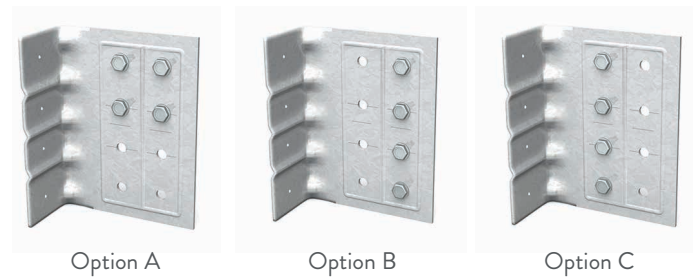

**Uni-Clip™ (UCEC) Allowable Loads (lbs)**

Anchor type	Stud thickness and yield strength	No. anchors to structure	Number/Configuration of Screws to Stud Framing											
			8 Screws			4 Screws (Option A)			4 Screws (Option B)			4 Screws (Option C)		
			F1	F2	F3	F1	F2	F3	F1	F2	F3	F1	F2	F3
Buildex #12-24 Tek 5 Self-Drilling Screws to 3/16" Steel	33mils (20ga) 33ksi	2	529	1121	1121	192	561	561	177	561	561	272	561	561
		3	529	1121	1121	192	561	561	177	561	561	272	561	561
		4	529	1121	1121	192	561	561	177	561	561	272	561	561
	43mils (18ga) 33ksi	2	784	1227	1664	285	832	832	263	832	832	404	832	832
		3	784	1664	1664	285	832	832	263	832	832	404	832	832
		4	784	1664	1664	285	832	832	263	832	832	404	832	832
	54mils (16ga) 33ksi	2	1105	1227	1889	402	920	1172	371	1172	1172	569	1172	1172
		3	1105	1841	1889	402	1172	1172	371	1172	1172	569	1172	1172
		4	1105	2345	1889	402	1172	1172	371	1172	1172	569	1172	1172
	54mils (16ga) 50ksi	2	1370	1227	1889	568	920	1417	523	1227	1209	804	1227	1655
		3	1560	1841	1889	568	1380	1417	523	1655	1209	804	1655	1655
		4	1560	2454	1889	568	1655	1417	523	1655	1209	804	1655	1655
PAF to 3/16" Steel*	33mils (20ga) 33ksi	2	529	511	1121	192	383	561	177	511	561	272	511	561
		3	529	767	1121	192	561	561	177	561	561	272	561	561
		4	529	1022	1121	192	561	561	177	561	561	272	561	561
	43mils (18ga) 33ksi	2	784	511	1664	285	383	832	263	511	832	404	511	832
		3	784	767	1664	285	575	832	263	767	832	404	767	832
		4	784	1022	1664	285	767	832	263	832	832	404	832	832
	54mils (16ga) 33ksi	2	1105	511	1889	402	383	1172	371	511	1172	569	511	1172
		3	1105	767	1889	402	575	1172	371	767	1172	569	767	1172
		4	1105	1022	1889	402	767	1172	371	1022	1172	569	1022	1172
	54mils (16ga) 50ksi	2	1117	511	1889	568	383	1417	523	511	1209	804	511	1655
		3	1560	767	1889	568	575	1417	523	767	1209	804	767	1655
		4	1560	1022	1889	568	767	1417	523	1022	1209	804	1022	1655

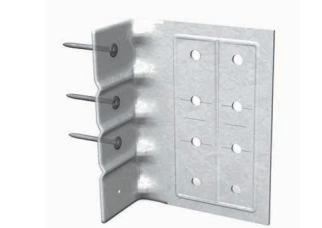

Location Options with (3) Anchors



Location Options with (3) Anchors

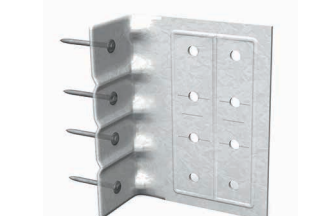

Location Options with (4) Anchors

\*See General Note #6 on page 9 for the definition of PAF, minimum requirements and other additional information.

**Notes:**

- 1 The 1/3 stress increase for wind shall not be used.
- 2 Attach the Uni-Clip to the stud framing using Buildex #10-16 (min.) self-drilling screws.
- 3 When using 2 anchors, use the outermost marks on the short leg of the clips for anchor placement.
- 4 Attach building anchors to the structure according to the manufacturer's instructions. Anchors shall be installed through the embossments on the scored line of the 1-1/2" leg of the clip.
- 5 When using #12-24 for clips that have load combinations of F1, F2 and F3, use a linear interaction for combinations of F1 and F3, and a squared interaction for combinations of F1 and F2. When using PAFs, use a linear interaction for combinations of F1 and F3, and for combinations of F1 and F2.
- 6 Capacities listed for PAFs are based on minimum PAF requirements listed in General Note #6 on page 9.
- 7 It is the responsibility of the design professional to detail the project drawings for proper clip installation.
- 8 For connections to concrete, or other technical assistance, contact ClarkDietrich at 888-437-3244.
- 9 Buildex is a registered trademark of Illinois Tool Works Inc.

## Extended Uni-Clip™

The Extended Uni-Clip™ connects exterior studs to the primary structure of the building, while resisting horizontal and vertical loads.

ClarkDietrich's Extended Uni-Clip™ rigid framing clip is used to attach exterior wall studs to the structure of the building. Designed to resist horizontal and vertical loads, the extended rigid clips install easily with screws, powder-actuated fasteners, or welds. This clip is ideal for all medium and large standoff conditions.

### ALTERNATIVE PRODUCTS

Universal Bypass Clip

### PRODUCT DIMENSIONS

- 6" Extended Uni-Clip: 1-7/8" x 4-7/8" x 6"
- 8" Extended Uni-Clip: 1-7/8" x 4-7/8" x 8"
- 10" Extended Uni-Clip: 1-7/8" x 4-7/8" x 10"
- 12" Extended Uni-Clip: 1-7/8" x 4-7/8" x 12"

### MATERIAL SPECIFICATIONS

- Gauge:** 14 gauge (68mils)
- Design Thickness:** 0.0713 inches
- Coating:** G90
- Yield Strength:** 50 ksi
- ASTM:** A653/A653M

### INSTALLATION

Attach the Extended Uni-Clip rigid clips to cold-formed steel framing members using #12 minimum self-drilling screws driven through the clip holes into the steel framing. Follow the required fastener placement patterns to achieve the allowable load. Connections to the primary building frame can also be made with powder-actuated fasteners or welds per design requirement.

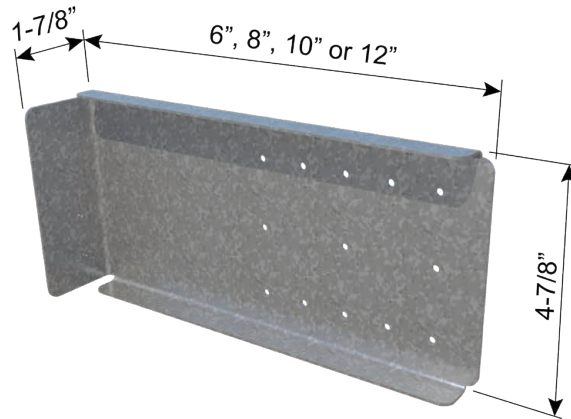

## Extended Uni-Clip™ (UXRC)

Product code	Thickness		Size (in)	Packaging Pcs./ Bucket
	Mils (Gauge)	Design thickness (in)		
UXRC6	68mils (14ga)	0.0713	1-7/8 x 4-7/8 x 6	25
UXRC8	68mils (14ga)	0.0713	1-7/8 x 4-7/8 x 8	25
UXRC10	68mils (14ga)	0.0713	1-7/8 x 4-7/8 x 10	25
UXRC12	68mils (14ga)	0.0713	1-7/8 x 4-7/8 x 12	25

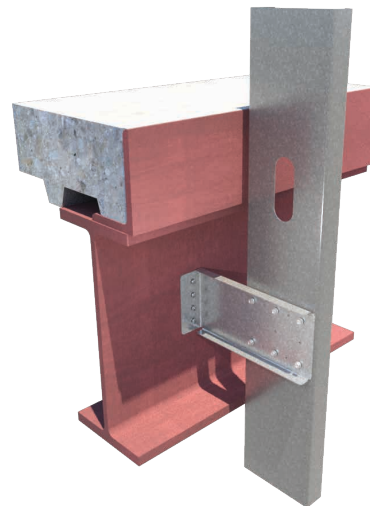



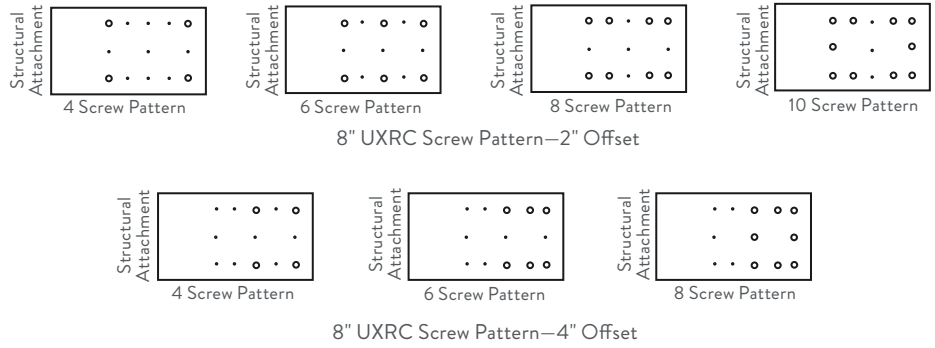
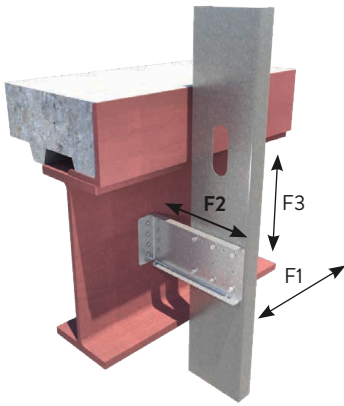

### Extended Uni-Clip™ (UXRC) Allowable Loads (KIPS)

Base connection	Stud thickness gauge (mils)	Stud Fy (ksi)	8" Extended Uni-Clip															
			2" Offset								4" Offset							
			F1 Load (kips)				F2 Load (kips)				F3 Load (kips)				F3 Load (kips)			
			4 screws	6 screws	8 screws	10 screws	4 screws	6 screws	8 screws	10 screws	4 screws	6 screws	8 screws	10 screws	4 screws	6 screws	8 screws	
Weld (Fillet/Flare Groove)	33mils (20ga)	33	0.381	0.453	0.453	0.453	0.754	1.131	1.508	1.884	0.310	0.435	0.572	0.686	0.214	0.306	0.363	
	43mils (18ga)	33	0.453	0.453	0.453	0.453	1.122	1.683	2.243	2.278	0.462	0.647	0.851	1.022	0.318	0.456	0.540	
	54mils (16ga)	33	0.453	0.453	0.453	0.453	1.577	2.278	2.278	2.278	0.649	0.909	1.196	1.436	0.447	0.640	0.759	
	54mils (16ga)	50	0.453	0.453	0.453	0.453	2.278	2.278	2.278	2.278	0.938	1.313	1.728	2.075	0.645	0.925	1.097	
	68mils (14ga)	50	0.453	0.453	0.453	0.453	2.278	2.278	2.278	2.278	1.098	1.538	2.022	2.278	0.756	1.083	1.284	
97mils (12ga)	50	0.453	0.453	0.453	0.453	2.278	2.278	2.278	2.278	1.098	1.538	2.022	2.278	0.756	1.083	1.284		
(4) #12-24 (3/16" steel)	33mils (20ga)	33	0.301	0.301	0.301	0.301	0.754	1.131	1.256	1.256	0.310	0.435	0.572	0.686	0.214	0.306	0.363	
	43mils (18ga)	33	0.301	0.301	0.301	0.301	1.122	1.256	1.256	1.256	0.462	0.647	0.851	1.022	0.318	0.456	0.540	
	54mils (16ga)	33	0.301	0.301	0.301	0.301	1.256	1.256	1.256	1.256	0.649	0.909	1.196	1.436	0.447	0.640	0.759	
	54mils (16ga)	50	0.301	0.301	0.301	0.301	1.256	1.256	1.256	1.256	0.938	1.313	1.728	1.864	0.645	0.925	1.097	
	68mils (14ga)	50	0.301	0.301	0.301	0.301	1.256	1.256	1.256	1.256	1.098	1.538	1.864	1.864	0.756	1.083	1.284	
97mils (12ga)	50	0.301	0.301	0.301	0.301	1.256	1.256	1.256	1.256	1.098	1.538	1.864	1.864	0.756	1.083	1.284		
(4) Hilti X-U (3/16" steel)	33mils (20ga)	33	0.301	0.301	0.301	0.301	0.754	0.875	0.875	0.875	0.310	0.435	0.572	0.686	0.214	0.306	0.363	
	43mils (18ga)	33	0.301	0.301	0.301	0.301	0.875	0.875	0.875	0.875	0.462	0.647	0.851	1.022	0.318	0.456	0.540	
	54mils (16ga)	33	0.301	0.301	0.301	0.301	0.875	0.875	0.875	0.875	0.649	0.909	1.196	1.436	0.447	0.640	0.759	
	54mils (16ga)	50	0.301	0.301	0.301	0.301	0.875	0.875	0.875	0.875	0.938	1.313	1.728	1.864	0.645	0.925	1.097	
	68mils (14ga)	50	0.301	0.301	0.301	0.301	0.875	0.875	0.875	0.875	1.098	1.538	1.864	1.864	0.756	1.083	1.284	
97mils (12ga)	50	0.301	0.301	0.301	0.301	0.875	0.875	0.875	0.875	1.098	1.538	1.864	1.864	0.756	1.083	1.284		
(4) Hilti X-U (1" embedment in 3000psi concrete)	33mils (20ga)	33	0.301	0.301	0.301	0.301	0.360	0.360	0.360	0.360	0.310	0.435	0.572	0.686	0.214	0.306	0.363	
	43mils (18ga)	33	0.301	0.301	0.301	0.301	0.360	0.360	0.360	0.360	0.462	0.647	0.747	0.747	0.318	0.456	0.540	
	54mils (16ga)	33	0.301	0.301	0.301	0.301	0.360	0.360	0.360	0.360	0.649	0.747	0.747	0.747	0.447	0.640	0.747	
	54mils (16ga)	50	0.301	0.301	0.301	0.301	0.360	0.360	0.360	0.360	0.747	0.747	0.747	0.747	0.645	0.747	0.747	
	68mils (14ga)	50	0.301	0.301	0.301	0.301	0.360	0.360	0.360	0.360	0.747	0.747	0.747	0.747	0.747	0.747	0.747	
97mils (12ga)	50	0.301	0.301	0.301	0.301	0.360	0.360	0.360	0.360	0.747	0.747	0.747	0.747	0.747	0.747	0.747		
(2) Kwik-Cons II (1-3/4" embedment in 3000psi concrete)	33mils (20ga)	33	0.301	0.301	0.301	0.301	0.754	0.922	0.922	0.922	0.310	0.435	0.572	0.686	0.214	0.306	0.363	
	43mils (18ga)	33	0.301	0.301	0.301	0.301	0.922	0.922	0.922	0.922	0.462	0.647	0.851	1.022	0.318	0.456	0.540	
	54mils (16ga)	33	0.301	0.301	0.301	0.301	0.922	0.922	0.922	0.922	0.649	0.909	1.160	1.160	0.447	0.640	0.759	
	54mils (16ga)	50	0.301	0.301	0.301	0.301	0.922	0.922	0.922	0.922	0.938	1.160	1.160	1.160	0.645	0.925	1.097	
	68mils (14ga)	50	0.301	0.301	0.301	0.301	0.922	0.922	0.922	0.922	1.098	1.160	1.160	1.160	0.756	1.083	1.160	
97mils (12ga)	50	0.301	0.301	0.301	0.301	0.922	0.922	0.922	0.922	1.098	1.160	1.160	1.160	0.756	1.083	1.160		

6", 10", and 12" tables are available at [clarkdietrich.com](http://clarkdietrich.com).

**Notes:**

- Capacities listed in the table/notes assume that no load reductions are required for spacing or edge distance of Hilti X-U pins in steel, Kwik-Cons, or screws. Load reductions are enforced for spacing or edge distance of Hilti X-U in concrete.
- Weld capacities are calculated for 2" long weld assuming 1" from the edges on the outer radius of the bend.
- Allowable loads have not been increased for wind, seismic, or other factors.
- The F1 values are calculated based on the moment capacity of the clip cross section.
- Capacities are based on the use of #12 screws to clip-stud interface.
- The embedment depth of Kwik-Cons in 3000psi normal weight concrete is 1-3/4". The embedment depth of Hilti X-U in 3000psi normal weight concrete is 1".
- The Hilti X-U pins and #12-24 screws are embedded in 3/16" structural steel.
- Torsional effects are considered on screw group for F3 allowable loads.
- Use a linear interaction equation for connections involving any combination of F1, F2, and F3.
- Hilti is a registered trademark of the Hilti Aktiengesellschaft Corporation.
- Hilti X-U PAFs shown in table may not be substituted without prior approval from ClarkDietrich Engineering Services.

## Extended Uni-Clip™ w/Anchor Holes

The Extended Uni-Clip™ connects exterior studs to the primary structure of the building, while resisting horizontal and vertical loads.

ClarkDietrich's UXRC6-HD 68mils (14ga) rigid framing clip is used to attach exterior wall studs to the structure of the building. This clip is ideal for all medium and large standoff conditions and designed to resist horizontal and vertical loads. (1) 5/8" hole in the short leg of the clip allows for a 1/2" concrete anchor to be attached to the slab. (2) 3/8" holes allow 1/4" anchors.

### MATERIAL SPECIFICATIONS

**Gauge:** 14 gauge (68mils)

**Design Thickness:** 0.0713 inches

**Coating:** G90

**Yield Strength:** 50 ksi

**ASTM:** A653/A653M

### INSTALLATION

Attach the Extended Uni-Clip rigid clips to cold-formed steel framing members using #12 minimum self-drilling screws driven through the clip holes into the steel framing. Follow the required fastener placement patterns to achieve the allowable load. Attachment to the structure concrete slab can be made with (1) 1/2" or (2) 1/4" bolt anchors. Anchor connection design and edge distance requirements must be approved by a design professional before installation.

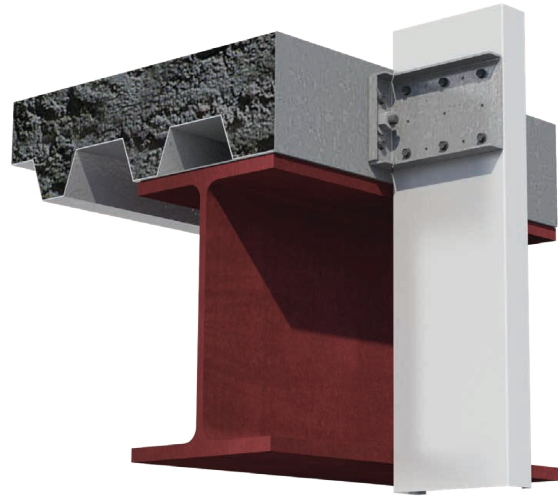

### PRODUCT DIMENSIONS

6" Extended Uni-Clip: 1-1/2" x 4-1/4" x 6"

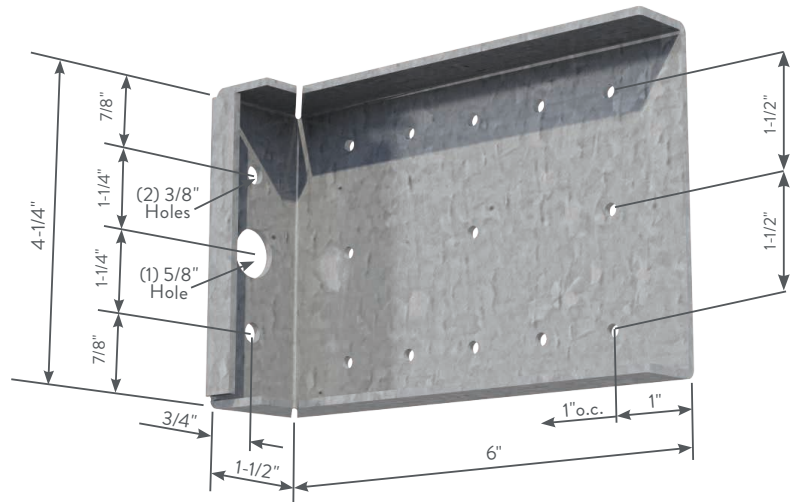

UXRC6-HD

## Extended Uni-Clip™ (UXRC6-HD)

Product code	Thickness		Size (in)	Packaging Pcs./ Bucket
	Mils (Gauge)	Design thickness (in)		
UXRC6-HD	68mils (14ga)	0.0713	1-1/2 x 4-1/4 x 6	25

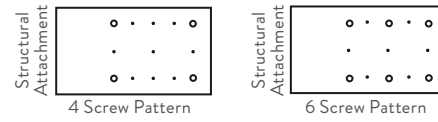
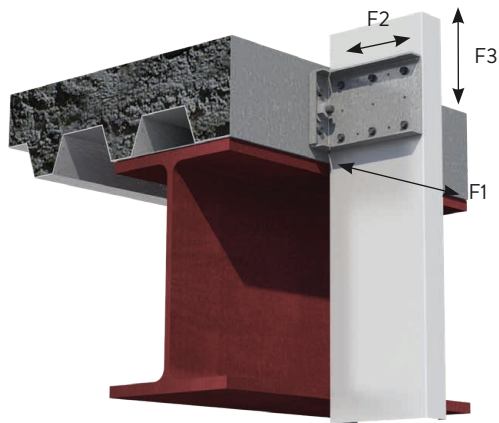

UXRC6-HD Screw Pattern

Extended Uni-Clip™ (UXRC6-HD) Allowable Loads

ANCHOR DESIGN BY OTHERS

Product name	Stud thickness Mils (Gauge)	Stud fy (ksi)	Mechanically Anchored to Structure	ASD Allowable Loads (lb.)					
				F1 Load		F2 Load		F3 Load	
				w/4 #12-14	w/6 #12-14	w/4 #12-14	w/6 #12-14	w/4 #12-14	w/6 #12-14
UXRC6-HD 14ga (68mils)	33mils (20ga)	33	Anchors to be designed by others	165	165	754	1131	361	471
	43mils (18ga)	33		232	232	1122	1428*	537	701
	54mils (16ga)	50		405	405	1428*	1428*	1091	1423
	68mils (14ga)	50		527	527	1568*	1568*	1488	1600
	97mils (12ga)	50		809	809	1667*	1667*	1488	1908

\* Capacities governed by 1/8" service load criteria.

Extended Uni-Clip™ (UXRC6-HD) Allowable Loads

CONSIDERING ANCHOR CAPACITIES

Product name	Stud thickness Mils (Gauge)	Stud fy (ksi)	Mechanically Anchored to Structure	ASD Allowable Loads (lb.)					
				F1 Load		F2 Load		F3 Load	
				w/4 #12-14	w/6 #12-14	w/4 #12-14	w/6 #12-14	w/4 #12-14	w/6 #12-14
UXRC6-HD 14ga (68mils)	33mils (20ga)	33	(1) 1/2" Hilti KWIK Bolt TZ <sup>1</sup>  (3000 psi uncracked concrete)	165	165	754	1131	351	471
	43mils (18ga)	33		232	232	1122	1199	502	682
	54mils (16ga)	50		405	405	1199	1199	983	1280
	68mils (14ga)	50		527	527	1339	1339	1336	1413
	97mils (12ga)	50		809	809	1339	1339	1488	1628
	33mils (20ga)	33	(2) 1/4" Hilti KWIK HUS-EZ <sup>1</sup>  (3000 psi uncracked concrete)	141	141	754	1131	361	471
	43mils (18ga)	33		207	207	1122	1403	537	701
	54mils (16ga)	50		397	397	1403	1403	1091	1423
	68mils (14ga)	50		484	484	1403	1403	1488	1600
	97mils (12ga)	50		803	803	1403	1403	1488	1838

Notes:

- Table-1 contains the allowable load capacity of the clip and the screw connection to the CFS stud. When the mechanical anchors between the clip and the support structure are designed by others, pull-over shall be included in the evaluation of F2 loads, and bearing shall be included in the evaluation of F3 loads.
- Table-2 considers capacities listed in Notes 3 and 4 (below) when the specified connectors to the structure are used.
- When using 1/2" Hilti KWIK Bolt TZ anchor (nominal embedment depth of 2-3/8") into 3000psi concrete, anchor capacity shall be limited to:
  - a Tension capacity/anchor: 1509-lbs (uncracked concrete) and 1069-lbs (cracked concrete)
  - b Shear capacity/anchor: 1628-lbs (uncracked concrete) and 1153-lbs (cracked concrete)
- When using 1/4" Hilti KWIK HUS-EZ anchor (nominal embedment depth of 2-1/2") into 3000psi concrete, anchor capacity shall be limited to:
  - a Tension capacity/anchor: 752-lbs (uncracked concrete) and 374-lbs (cracked concrete)
  - b Shear capacity/anchor: 919-lbs (uncracked concrete) and 651-lbs (cracked concrete)
- Connector capacities listed in Note 4 utilize load adjustment/reduction (anchor spacing) factors of 0.72 for tension and 0.60 for shear as per 2016 Hilti Anchor Fastening Technical Guide (see Hilti Table 6 and 7 under section 3.3.6.3).
- Where anchors are loaded simultaneously in tension and shear, interaction must be considered following anchor manufacturer guidelines.
- Capacities listed in the table/notes did not consider load adjustment for edge distance of anchors. For no reduction in the listed capacities, the following requirements needed to be met for the concrete surface where the clip attaches:
  - a When using 1/2" Hilti KWIK Bolt TZ anchor embedded 2-3/8" deep into 3000psi concrete, minimum edge distance shall be:
    - i) 5-1/2" for uncracked concrete;
    - ii) 4-1/8" for cracked concrete
  - b When using 1/4" Hilti KWIK HUS-EZ anchors embedded 2-1/2" deep into 3000psi concrete, minimum edge distance shall be:
    - i) 4-1/2" for uncracked concrete
    - ii) 4-1/2" for cracked concrete
- Other anchors may be used to achieve the full clip capacity but must be designed separately.
- Allowable loads have not been increased for wind, seismic, or other factors.
- Hilti is a registered trademark of Hilti Aktiengesellschaft Corporation.
- It is the responsibility of the designer to properly detail connections on the contract drawings.

## Universal Bypass Clip

Provides either a rigid connection or vertical building movement up to 3"

Universal Bypass Clips are used to attach exterior curtain wall studs to the building structure and provide either a rigid connection or deflecting connection for vertical building movement independent of the cold-formed steel framing.

The clips are available in standard lengths of 6", 8", 10" and 12" and are ideal for medium to larger standoff conditions. Universal Bypass Clips install quickly with screws, welds or powder-actuated fasteners, and provide adjustable standoff to ensure a plumb wall plane. For deflection application, proprietary deflection screws are provided with each clip to ensure friction-free sliding.

- Eliminates shims and scabs.
- Provides vertical movement up to 3" (1-1/2" up and 1-1/2" down) when installed as a deflection application.
- Specially designed to simplify welding installation.
- Fast, one-piece universal installation.  
No left or right handed clips.
- Proprietary deflection screws provide frictionless slip connections. One bag (80 screws) included.

### ALTERNATIVE PRODUCTS

FastClip™ Slide Clip  
Extended FastClip™ Slide Clip  
Extended Uni-Clip™

### MATERIAL SPECIFICATIONS

**Gauge:** 14 gauge (68mils)

**Design Thickness:** 0.0713 inches

**Gauge:** 12 gauge (97mils)

**Design Thickness:** 0.1017 inches

**Yield Strength:** Structural Grade 50 Type H (ST50H), 50ksi (340 MPa)

**Coating:** G90 (Z275) hot-dipped galvanized coating

**ASTM:** A653, A1003

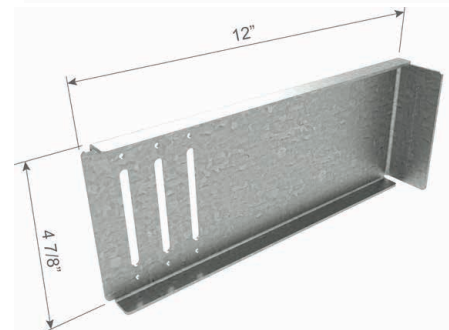
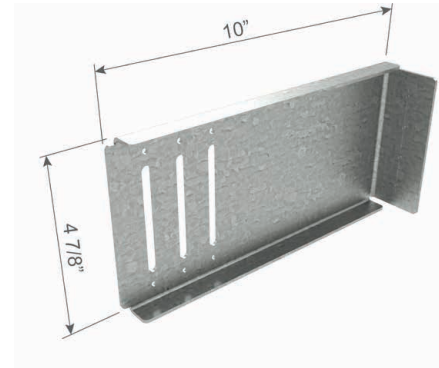
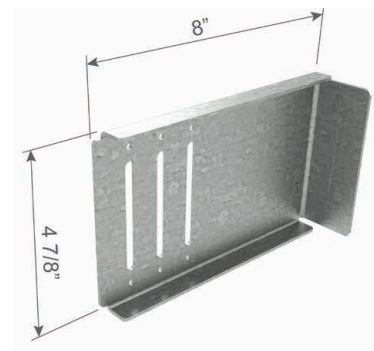
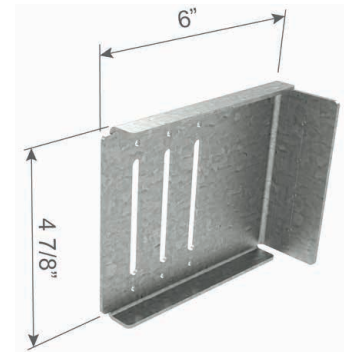

### Universal Bypass Clip (UBC)

Product code	Mils (Gauge)	Design thickness	Size (in)	Pcs/Bucket
UBC6-68	68mils (14ga)	0.0713	1-7/8" x 6" x 4-7/8"	25
UBC8-68	68mils (14ga)	0.0713	1-7/8" x 8" x 4-7/8"	25
UBC10-68	68mils (14ga)	0.0713	1-7/8" x 10" x 4-7/8"	25
UBC12-68	68mils (14ga)	0.0713	1-7/8" x 12" x 4-7/8"	25
UBC6-97	97mils (12ga)	0.1017	1-7/8" x 6" x 4-7/8"	25
UBC8-97	97mils (12ga)	0.1017	1-7/8" x 8" x 4-7/8"	25
UBC10-97	97mils (12ga)	0.1017	1-7/8" x 10" x 4-7/8"	25
UBC12-97	97mils (12ga)	0.1017	1-7/8" x 12" x 4-7/8"	25

## INSTALLATION

Connections to the building can be made with screws, welds powder-actuated fasteners. Mechanical fasteners shall be located on the embossed marks given on the scored line of the 1-7/8" flange. Attach building anchors to the structure according to the manufacture's instructions. Anchors shall be installed through the embossments on the scored line of the clip as shown on the attached drawings. In no case shall anchors be installed more than 3/4" from the bend on the short leg of the clip. In cases of discrepancy between this information and the Design Engineer's details, the Design Engineer's details shall be followed.

### For a Rigid Connection:

Attach the Universal Bypass Clip to cold-formed steel framing members using (6) #10-16 minimum self-drilling screws (not included) for the 14ga clip and (6) #12-14 minimum self-drilling screws (not included) for the 12ga clip, through the clip holes into the steel framing.

### For a Deflection Connection:

Attach the Universal Bypass Clip to the cold-formed steel framing using (3) #14 proprietary deflection screws (included) through the (3) slotted holes and positioned to allow for the appropriate building deflection.

### Proprietary Deflection Screws:

Many of the ClarkDietrich deflection clips include our proprietary deflection fastener that has been specifically designed to provide friction-free deflection. These fasteners eliminate drag, binding or resistance that can often occur with common fasteners.

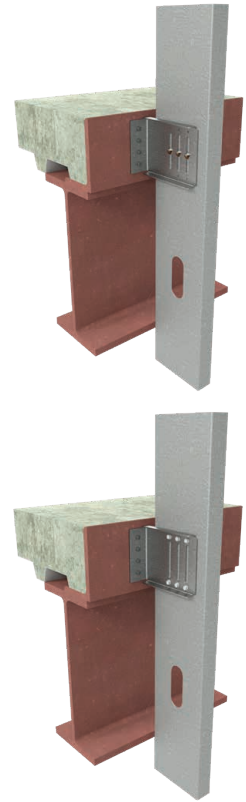

## Universal Bypass Clip

### UBC - 14ga (As a Rigid Connection w/ (6) screws)

ATTACHMENT TO STRUCTURAL: **DESIGNED BY OTHERS**

Clip designation	Stud gauge (mils) Yield Strength	ASD Allowable Loads (lbs)			
		F1 (In-Plane) w/ (6) #10-16	F2 (Tension) w/ (6) #10-16	F3 (Compression) w/ (6) #10-16	F4 (Shear) w/ (6) #10-16
UBC6-68 68mils (14ga)	33mils (20ga) 33ksi	165	1060	1060	395
	43mils (18ga) 33ksi	215	1450	1575	590
	54mils (16ga) 50ksi	255	1450	1590	1055
	68mils (14ga) 50ksi	255	1450	1590	1055
	97mils (12ga) 50ksi	255	1450	1590	1055
UBC8-68 68mils (14ga)	33mils (20ga) 33ksi	165	1060	1060	290
	43mils (18ga) 33ksi	215	1450	1405	430
	54mils (16ga) 50ksi	220	1450	1405	770
	68mils (14ga) 50ksi	220	1450	1405	770
	97mils (12ga) 50ksi	220	1450	1405	770
UBC10-68 68mils (14ga)	33mils (20ga) 33ksi	165	1060	1060	225
	43mils (18ga) 33ksi	190	1450	1385	340
	54mils (16ga) 50ksi	190	1450	1385	605
	68mils (14ga) 50ksi	190	1450	1385	605
	97mils (12ga) 50ksi	190	1450	1385	605
UBC12-68 68mils (14ga)	33mils (20ga) 33ksi	160	1060	1060	185
	43mils (18ga) 33ksi	160	1430	1285	280
	54mils (16ga) 50ksi	160	1430	1285	495
	68mils (14ga) 50ksi	160	1430	1285	495
	97mils (12ga) 50ksi	160	1430	1285	495

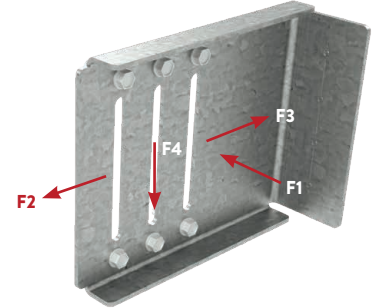

- Notes:**
- 1 Allowable loads (ASD) listed represent the capacity of the clip to the stud only. (Framing Connection)
  - 2 Allowable Loads have not been increased for the wind, seismic, or other factors.
  - 3 An 1/8-in service deflection load limit was applied to clips resisting F2, F3 and F4 loads. In accordance with ICC AC 261, service deflection limit was not applied to clips resisting F1 loads.
  - 4 Listed capacities are based on the maximum screw pattern. For maximum screw pattern for a Rigid Clip, fill screws in (6) round holes.
  - 5 For 12ga Rigid clip, (6) #12-14 screws shall be installed in the pilot holes. For 14ga Rigid clip, (6) #10-16 screws shall be installed in the pilot holes.
  - 6 It is the responsibility of the design professional to design the attachment of the clips to the structure and verify that their capacity meets the requirements of the intended application.
  - 7 Nominal or LRFD loads are available upon request.

### UBC - 14ga (As a Rigid Connection w/ (6) screws)

ATTACHMENT TO STRUCTURAL: **WELDED**

Clip designation	Stud gauge (mils) Yield Strength	ASD Allowable Loads (lbs)			
		F1 (In-Plane) w/ (6) #10-16	F2 (Tension) w/ (6) #10-16	F3 (Compression) w/ (6) #10-16	F4 (Shear) w/ (6) #10-16
UBC6-68 68mils (14ga)	33mils (20ga) 33ksi	165	1060	1060	395
	43mils (18ga) 33ksi	215	1575	1575	590
	54mils (16ga) 50ksi	255	1755	1590	1055
	68mils (14ga) 50ksi	255	1755	1590	1055
	97mils (12ga) 50ksi	255	1755	1590	1055
UBC8-68 68mils (14ga)	33mils (20ga) 33ksi	165	1060	1060	290
	43mils (18ga) 33ksi	215	1575	1405	430
	54mils (16ga) 50ksi	220	1675	1405	770
	68mils (14ga) 50ksi	220	1675	1405	770
	97mils (12ga) 50ksi	220	1675	1405	770
UBC10-68 68mils (14ga)	33mils (20ga) 33ksi	165	1060	1060	225
	43mils (18ga) 33ksi	190	1575	1385	340
	54mils (16ga) 50ksi	190	1675	1385	605
	68mils (14ga) 50ksi	190	1675	1385	605
	97mils (12ga) 50ksi	190	1675	1385	605
UBC12-68 68mils (14ga)	33mils (20ga) 33ksi	160	1060	1060	185
	43mils (18ga) 33ksi	160	1575	1285	280
	54mils (16ga) 50ksi	160	1675	1285	495
	68mils (14ga) 50ksi	160	1675	1285	495
	97mils (12ga) 50ksi	160	1675	1285	495

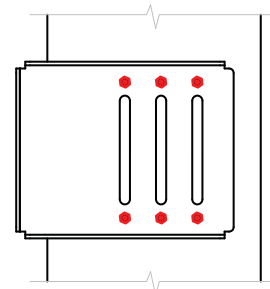
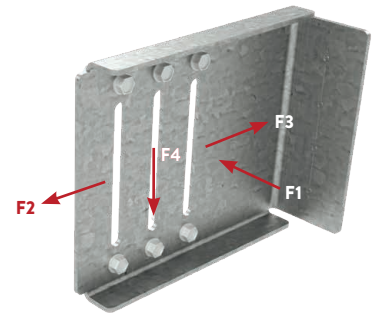

12ga Clip: (6) #12-14 Screws  
14ga Clip: (6) #10-16 Screws  
Shown in a UBC6 Clip

- Notes:**
- 1 Allowable Loads (ASD) have not been increased for the wind, seismic, or other factors.
  - 2 Listed capacities are based on the maximum screw pattern. For maximum screw pattern for a Rigid Clip, fill screws in (6) round holes.
  - 3 For 12ga Rigid clip, (6) #12-14 screws shall be installed in the pilot holes. For 14ga Rigid clip, (6) #10-16 screws shall be installed in the pilot holes.
  - 4 The Allowable loads listed for welds are based on the following weld lengths:  
- (2) Welds - 1" along back of short leg clip bend (each weld equally distanced from center of clip).
  - 5 Use E70XX (min.) electrodes.
  - 6 It is the responsibility of the design professional to verify that the connection design meets the requirements of the intended application.
  - 7 Nominal or LRFD loads are available upon request.

**UBC - 14ga (As a Rigid Connection w/ (6) screws)**

**ATTACHMENT TO STRUCTURAL: (4) #12-24 FASTENERS**

Clip designation	Stud gauge (mils) Yield Strength	ASD Allowable Loads (lbs)			
		F1 (In-Plane) w/ (6) #10-16	F2 (Tension) w/ (6) #10-16	F3 (Compression) w/ (6) #10-16	F4 (Shear) w/ (6) #10-16
UBC6-68 68mils (14ga)	33mils (20ga) 33ksi	165	1060	1060	395
	43mils (18ga) 33ksi	215	1450	1575	590
	54mils (16ga) 50ksi	255	1450	1590	1055
	68mils (14ga) 50ksi	255	1450	1590	1055
	97mils (12ga) 50ksi	255	1450	1590	1055
UBC8-68 68mils (14ga)	33mils (20ga) 33ksi	165	1060	1060	290
	43mils (18ga) 33ksi	215	1450	1405	430
	54mils (16ga) 50ksi	220	1450	1405	770
	68mils (14ga) 50ksi	220	1450	1405	770
	97mils (12ga) 50ksi	220	1450	1405	770
UBC10-68 68mils (14ga)	33mils (20ga) 33ksi	165	1060	1060	225
	43mils (18ga) 33ksi	190	1450	1385	340
	54mils (16ga) 50ksi	190	1450	1385	605
	68mils (14ga) 50ksi	190	1450	1385	605
	97mils (12ga) 50ksi	190	1450	1385	605
UBC12-68 68mils (14ga)	33mils (20ga) 33ksi	160	1060	1060	185
	43mils (18ga) 33ksi	160	1430	1285	280
	54mils (16ga) 50ksi	160	1430	1285	495
	68mils (14ga) 50ksi	160	1430	1285	495
	97mils (12ga) 50ksi	160	1430	1285	495

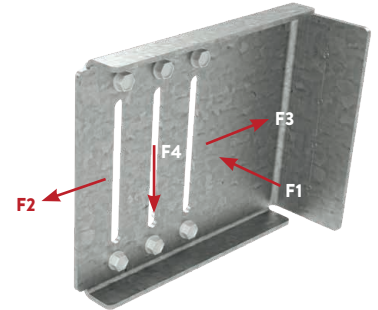

**Notes:**

- 1 Allowable Loads (ASD) have not been increased for the wind, seismic, or other factors.
- 2 An 1/8-in service deflection load limit was applied to clips resisting F2, F3 and F4 loads. In accordance with ICC AC 261, service deflection limit was not applied to clips resisting F1 loads.
- 3 Listed capacities are based on the maximum screw pattern. For maximum screw pattern for a Rigid Clip, fill screws in (6) round holes.
- 4 For 12ga Rigid clip, (6) #12-14 screws shall be installed in the pilot holes. For 14ga Rigid clip, (6) #10-16 screws shall be installed in the pilot holes.
- 5 #12-24 Fasteners shall be used for attachment to steel structure. (4) Fastener configuration shall be used. Screws should be placed at indentations scribed on the short leg of the UBC clip.
- 6 The minimum edge distance for each fastener type shall comply with the fastener manufacturer's recommendation.
- 7 It is the responsibility of the design professional to verify that the connection design meets the requirements of the intended application.
- 8 Nominal or LRFD loads are available upon request.

**UBC - 14ga (As a Rigid Connection w/ (6) screws)**

**ATTACHMENT TO STRUCTURAL: (4) 0.157" PAFs**

Clip designation	Stud gauge (mils) Yield Strength	ASD Allowable Loads (lbs)			
		F1 (In-Plane) w/ (6) #10-16	F2 (Tension) w/ (6) #10-16	F3 (Compression) w/ (6) #10-16	F4 (Shear) w/ (6) #10-16
UBC6-68 68mils (14ga)	33mils (20ga) 33ksi	165	1060	1060	395
	43mils (18ga) 33ksi	215	1450	1575	590
	54mils (16ga) 50ksi	255	1450	1590	1055
	68mils (14ga) 50ksi	255	1450	1590	1055
	97mils (12ga) 50ksi	255	1450	1590	1055
UBC8-68 68mils (14ga)	33mils (20ga) 33ksi	165	1060	1060	290
	43mils (18ga) 33ksi	215	1450	1405	430
	54mils (16ga) 50ksi	220	1450	1405	770
	68mils (14ga) 50ksi	220	1450	1405	770
	97mils (12ga) 50ksi	220	1450	1405	770
UBC10-68 68mils (14ga)	33mils (20ga) 33ksi	165	1060	1060	225
	43mils (18ga) 33ksi	190	1450	1385	340
	54mils (16ga) 50ksi	190	1450	1385	605
	68mils (14ga) 50ksi	190	1450	1385	605
	97mils (12ga) 50ksi	190	1450	1385	605
UBC12-68 68mils (14ga)	33mils (20ga) 33ksi	160	1060	1060	185
	43mils (18ga) 33ksi	160	1430	1285	280
	54mils (16ga) 50ksi	160	1430	1285	495
	68mils (14ga) 50ksi	160	1430	1285	495
	97mils (12ga) 50ksi	160	1430	1285	495

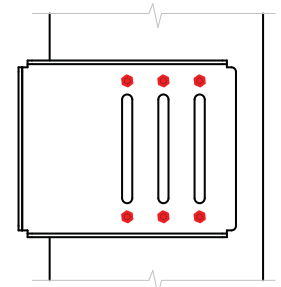
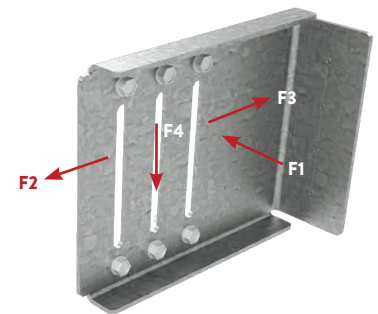

**Notes:**

- 1 Allowable Loads (ASD) have not been increased for the wind, seismic, or other factors.
- 2 Nominal or LRFD loads are available upon request.
- 3 Listed capacities are based on the maximum screw pattern. For maximum screw pattern for a Rigid Clip, fill screws in (6) round holes.
- 4 For 12ga Rigid clip, (6) #12-14 screws shall be installed in the pilot holes. For 14ga Rigid clip, (6) #10-16 screws shall be installed in the pilot holes.
- 5 0.157" Hilti X-U PAFs shall be used for attachment to steel structure. (4) Fastener configuration shall be used. PAFs should be placed at indentations scribed on the short leg of the UBC clip.
- 6 Capacities considered for Hilti PAFs are based on fastener strengths listed in ICC ESR-2269.
- 7 It is the responsibility of the design professional to verify that the connection design meets the requirements of the intended application.
- 8 An 1/8-in service deflection load limit was applied to clips resisting F2, F3 and F4 loads. In accordance with ICC AC 261, service deflection limit was not applied to clips resisting F1 loads.

## Universal Bypass Clip

### UBC - 12ga (As a Rigid Connection w/ (6) screws)

ATTACHMENT TO STRUCTURAL: **DESIGNED BY OTHERS**

Clip designation	Stud gauge (mils) Yield Strength	ASD Allowable Loads (lbs)			
		F1 (In-Plane) w/ (6) #12-14	F2 (Tension) w/ (6) #12-14	F3 (Compression) w/ (6) #12-14	F4 (Shear) w/ (6) #12-14
UBC6-97 97mils (12ga)	33mils (20ga) 33ksi	190	1130	1130	425
	43mils (18ga) 33ksi	245	1680	1680	630
	54mils (16ga) 50ksi	265	2115	2540	1230
	68mils (14ga) 50ksi	265	2115	2540	1230
	97mils (12ga) 50ksi	265	2115	2540	1230
UBC8-97 97mils (12ga)	33mils (20ga) 33ksi	190	1130	1130	310
	43mils (18ga) 33ksi	240	1680	1680	460
	54mils (16ga) 50ksi	240	2115	2315	885
	68mils (14ga) 50ksi	240	2115	2315	885
	97mils (12ga) 50ksi	240	2115	2315	885
UBC10-97 97mils (12ga)	33mils (20ga) 33ksi	190	1130	1130	245
	43mils (18ga) 33ksi	225	1680	1680	360
	54mils (16ga) 50ksi	225	2115	2055	690
	68mils (14ga) 50ksi	225	2115	2055	690
	97mils (12ga) 50ksi	225	2115	2055	690
UBC12-97 97mils (12ga)	33mils (20ga) 33ksi	190	1130	1130	200
	43mils (18ga) 33ksi	195	1680	1680	295
	54mils (16ga) 50ksi	195	2115	2055	605
	68mils (14ga) 50ksi	195	2115	2055	630
	97mils (12ga) 50ksi	195	2115	2055	630

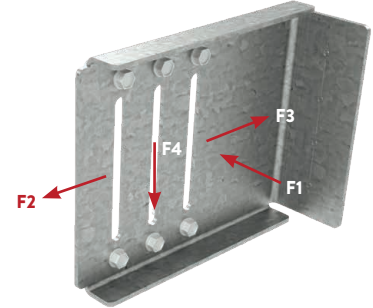

**Notes:**

- 1 Allowable loads (ASD) listed represent the capacity of the clip to the stud only. (Framing Connection)
- 2 Allowable Loads have not been increased for the wind, seismic, or other factors.
- 3 An 1/8-in service deflection load limit was applied to clips resisting F2, F3 and F4 loads. In accordance with ICC AC 261, service deflection limit was not applied to clips resisting F1 loads.
- 4 Listed capacities are based on the maximum screw pattern. For maximum screw pattern for a Rigid Clip, fill screws in (6) round holes.
- 5 For 12ga Rigid clip, (6) #12-14 screws shall be installed in the pilot holes. For 14ga Rigid clip, (6) #10-16 screws shall be installed in the pilot holes.
- 6 It is the responsibility of the design professional to design the attachment of the clips to the structure and verify that their capacity meets the requirements of the intended application.
- 7 Nominal or LRFD loads are available upon request.

### UBC - 12ga (As a Rigid Connection w/ (6) screws)

ATTACHMENT TO STRUCTURAL: **WELDED**

Clip designation	Stud gauge (mils) Yield Strength	ASD Allowable Loads (lbs)			
		F1 (In-Plane) w/ (6) #12-14	F2 (Tension) w/ (6) #12-14	F3 (Compression) w/ (6) #12-14	F4 (Shear) w/ (6) #12-14
UBC6-97 97mils (12ga)	33mils (20ga) 33ksi	190	1130	1130	425
	43mils (18ga) 33ksi	245	1680	1680	630
	54mils (16ga) 50ksi	265	2110	2540	1230
	68mils (14ga) 50ksi	265	2110	2540	1230
	97mils (12ga) 50ksi	265	2110	2540	1230
UBC8-97 97mils (12ga)	33mils (20ga) 33ksi	190	1130	1130	310
	43mils (18ga) 33ksi	240	1680	1680	460
	54mils (16ga) 50ksi	240	2110	2315	885
	68mils (14ga) 50ksi	240	2110	2315	885
	97mils (12ga) 50ksi	240	2110	2315	885
UBC10-97 97mils (12ga)	33mils (20ga) 33ksi	190	1130	1130	245
	43mils (18ga) 33ksi	225	1680	1680	360
	54mils (16ga) 50ksi	225	2110	2055	690
	68mils (14ga) 50ksi	225	2110	2055	690
	97mils (12ga) 50ksi	225	2110	2055	690
UBC12-97 97mils (12ga)	33mils (20ga) 33ksi	190	1130	1130	200
	43mils (18ga) 33ksi	195	1680	1680	295
	54mils (16ga) 50ksi	195	2110	2055	605
	68mils (14ga) 50ksi	195	2110	2055	630
	97mils (12ga) 50ksi	195	2110	2055	630

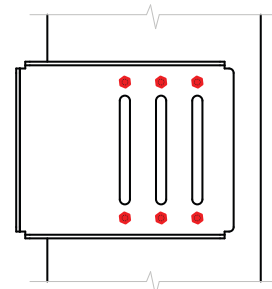
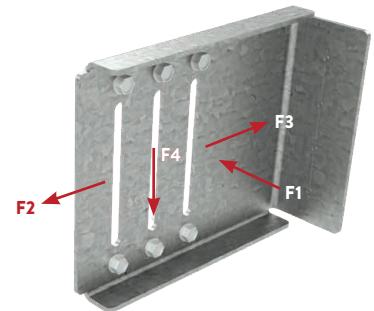

12ga Clip: (6) #12-14 Screws  
14ga Clip: (6) #10-16 Screws  
Shown in a UBC6 Clip

**Notes:**

- 1 Allowable Loads (ASD) have not been increased for the wind, seismic, or other factors.
- 2 Listed capacities are based on the maximum screw pattern. For maximum screw pattern for a Rigid Clip, fill screws in (6) round holes.
- 3 For 12ga Rigid clip, (6) #12-14 screws shall be installed in the pilot holes. For 14ga Rigid clip, (6) #10-16 screws shall be installed in the pilot holes.
- 4 The Allowable loads listed for welds are based on the following weld lengths:  
- (2) Welds - 1" along back of short leg clip bend (each weld equally distanced from center of clip).
- 5 Use E70XX (min.) electrodes.
- 6 It is the responsibility of the design professional to verify that the connection design meets the requirements of the intended application.
- 7 Nominal or LRFD loads are available upon request.



**UBC - 12ga (As a Rigid Connection w/ (6) screws)**

**ATTACHMENT TO STRUCTURAL: (4) #12-24 FASTENERS**

Clip designation	Stud gauge (mils) Yield Strength	ASD Allowable Loads (lbs)			
		F1 (In-Plane) w/ (6) #12-14	F2 (Tension) w/ (6) #12-14	F3 (Compression) w/ (6) #12-14	F4 (Shear) w/ (6) #12-14
UBC6-97 97mils (12ga)	33mils (20ga) 33ksi	190	1130	1130	425
	43mils (18ga) 33ksi	245	1680	1680	630
	54mils (16ga) 50ksi	265	2115	2540	1230
	68mils (14ga) 50ksi	265	2115	2540	1230
	97mils (12ga) 50ksi	265	2115	2540	1230
UBC8-97 97mils (12ga)	33mils (20ga) 33ksi	190	1130	1130	310
	43mils (18ga) 33ksi	240	1680	1680	460
	54mils (16ga) 50ksi	240	2115	2315	885
	68mils (14ga) 50ksi	240	2115	2315	885
	97mils (12ga) 50ksi	240	2115	2315	885
UBC10-97 97mils (12ga)	33mils (20ga) 33ksi	190	1130	1130	245
	43mils (18ga) 33ksi	225	1680	1680	360
	54mils (16ga) 50ksi	225	2115	2055	690
	68mils (14ga) 50ksi	225	2115	2055	690
	97mils (12ga) 50ksi	225	2115	2055	690
UBC12-97 97mils (12ga)	33mils (20ga) 33ksi	190	1130	1130	200
	43mils (18ga) 33ksi	195	1680	1680	295
	54mils (16ga) 50ksi	195	2115	2055	605
	68mils (14ga) 50ksi	195	2115	2055	630
	97mils (12ga) 50ksi	195	2115	2055	630

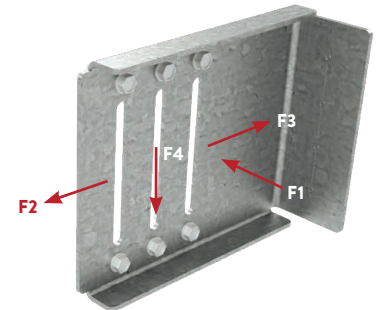

**Notes:**

- 1 Allowable Loads (ASD) have not been increased for the wind, seismic, or other factors.
- 2 An 1/8-in service deflection load limit was applied to clips resisting F2, F3 and F4 loads. In accordance with ICC AC 261, service deflection limit was not applied to clips resisting F1 loads.
- 3 Listed capacities are based on the maximum screw pattern. For maximum screw pattern for a Rigid Clip, fill screws in (6) round holes.
- 4 For 12ga Rigid clip, (6) #12-14 screws shall be installed in the pilot holes. For 14ga Rigid clip, (6) #10-16 screws shall be installed in the pilot holes.
- 5 #12-24 Fasteners shall be used for attachment to steel structure. (4) Fastener configuration shall be used. Screws should be placed at indentations scribed on the short leg of the UBC clip.
- 6 The minimum edge distance for each fastener type shall comply with the fastener manufacturer's recommendation.
- 7 It is the responsibility of the design professional to verify that the connection design meets the requirements of the intended application.
- 8 Nominal or LRFD loads are available upon request.

**UBC - 12ga (As a Rigid Connection w/ (6) screws)**

**ATTACHMENT TO STRUCTURAL: (4) 0.157" PAFs**

Clip designation	Stud gauge (mils) Yield Strength	ASD Allowable Loads (lbs)			
		F1 (In-Plane) w/ (6) #12-14	F2 (Tension) w/ (6) #12-14	F3 (Compression) w/ (6) #12-14	F4 (Shear) w/ (6) #12-14
UBC6-97 97mils (12ga)	33mils (20ga) 33ksi	190	1130	1130	425
	43mils (18ga) 33ksi	245	1680	1680	630
	54mils (16ga) 50ksi	265	2000	2540	1230
	68mils (14ga) 50ksi	265	2000	2540	1230
	97mils (12ga) 50ksi	265	2000	2540	1230
UBC8-97 97mils (12ga)	33mils (20ga) 33ksi	190	1130	1130	310
	43mils (18ga) 33ksi	240	1680	1680	460
	54mils (16ga) 50ksi	240	2000	2315	885
	68mils (14ga) 50ksi	240	2000	2315	885
	97mils (12ga) 50ksi	240	2000	2315	885
UBC10-97 97mils (12ga)	33mils (20ga) 33ksi	190	1130	1130	245
	43mils (18ga) 33ksi	225	1680	1680	360
	54mils (16ga) 50ksi	225	2000	2055	690
	68mils (14ga) 50ksi	225	2000	2055	690
	97mils (12ga) 50ksi	225	2000	2055	690
UBC12-97 97mils (12ga)	33mils (20ga) 33ksi	190	1130	1130	200
	43mils (18ga) 33ksi	195	1680	1680	295
	54mils (16ga) 50ksi	195	2000	2055	605
	68mils (14ga) 50ksi	195	2000	2055	630
	97mils (12ga) 50ksi	195	2000	2055	630

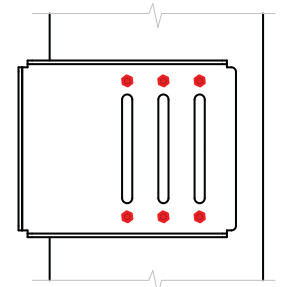
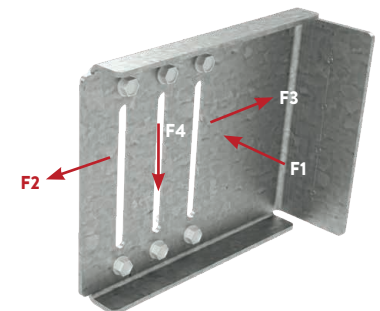

12ga Clip: (6) #12-14 Screws  
14ga Clip: (6) #10-16 Screws  
Shown in a UBC6 Clip

**Notes:**

- 1 Allowable Loads (ASD) have not been increased for the wind, seismic, or other factors.
- 2 Nominal or LRFD loads are available upon request.
- 3 Listed capacities are based on the maximum screw pattern. For maximum screw pattern for a Rigid Clip, fill screws in (6) round holes.
- 4 For 12ga Rigid clip, (6) #12-14 screws shall be installed in the pilot holes. For 14ga Rigid clip, (6) #10-16 screws shall be installed in the pilot holes.
- 5 0.157" Hilti X-U PAFs shall be used for attachment to steel structure. (4) Fastener configuration shall be used. PAFs should be placed at indentations scribed on the short leg of the UBC clip.
- 6 Capacities considered for Hilti PAFs are based on fastener strengths listed in ICC ESR-2269.
- 7 It is the responsibility of the design professional to verify that the connection design meets the requirements of the intended application.
- 8 An 1/8-in service deflection load limit was applied to clips resisting F2, F3 and F4 loads. In accordance with ICC AC 261, service deflection limit was not applied to clips resisting F1 loads.

## SwiftClip™ L-Series™ Support Clip

Support for the most demanding applications.

SwiftClip™ L-Series™ support clips are used in multiple construction projects, specifically in conjunction with structural studs and track. The L-shaped clips fit between the stud flanges, so that shorter length clips do not need to be ordered. These labor time-savers include prepunched holes for quicker screw attachments, and are punched to accommodate for CRC lateral bracing connections.

### ALTERNATIVE PRODUCTS

- EasyClip™ E-Series™ Support Clip
- EasyClip S-Series™ Support Clip
- EasyClip U-Series™ Clip Angle
- FastBridge™ Clip
- EasyClip X-Series™ Clip Angle
- EasyClip A-Series™ End Clip

### PRODUCT DIMENSIONS

See chart below for available sizes.

### MATERIAL SPECIFICATIONS

**Gauge:** 16 gauge (54mils)  
**Design Thickness:** 0.0566 inches

**Gauge:** 14 gauge (68mils)  
**Design Thickness:** 0.0713 inches

**Gauge:** 12 gauge (97mils)  
**Design Thickness:** 0.1017 inches

**Coating:** G90  
**Yield Strength:** 50ksi  
**ASTM:** A653/A653M

## SwiftClip™ L-Series™ Support Clip

Product code	Thickness		Size (in)	Common application	Packaging Pcs./Bucket
	Mils (Gauge)	Design thickness (in)			
LS543	54mils (16ga)	0.0566	1-1/2 x 1-1/2 x 3-1/4	CRC/Openings	300
LS683	68mils (14ga)	0.0713		Openings	300
LS973	97mils (12ga)	0.1017		Openings	200
LS545	54mils (16ga)	0.0566	1-1/2 x 1-1/2 x 5-1/2	CRC/Openings/Joists	200
LS685	68mils (14ga)	0.0713		Openings/Joists	200
LS975	97mils (12ga)	0.1017		Openings/Joists	100
LS547	54mils (16ga)	0.0566	1-1/2 x 1-1/2 x 7-1/4	CRC/Openings/Joists	150
LS687	68mils (14ga)	0.0713		Openings/Joists	100
LS977	97mils (12ga)	0.1017		Openings/Joists	100
LS549	54mils (16ga)	0.0566	1-1/2 x 1-1/2 x 9-1/4	Joists	100
LS689	68mils (14ga)	0.0713		Joists	100
LS979	97mils (12ga)	0.1017		Joists	50
LS541	54mils (16ga)	0.0566	1-1/2 x 1-1/2 x 11-1/4	Joists	100
LS681	68mils (14ga)	0.0713		Joists	50
LS971	97mils (12ga)	0.1017		Joists	50
LS5413	54mils (16ga)	0.0566	1-1/2 x 1-1/2 x 13-1/4	Joists	50
LS6813	68mils (14ga)	0.0713		Joists	50
LS9713	97mils (12ga)	0.1017		Joists	25
LE543	54mils (16ga)	0.0566	1-1/2 x 3 x 3-1/4	Fixed/Joists/Trusses	100
LE683	68mils (14ga)	0.0713		Fixed/Joists/Trusses	100
LE973	97mils (12ga)	0.1017		Fixed/Joists/Trusses	50
LE545	54mils (16ga)	0.0566	1-1/2 x 3 x 5-1/2	Fixed/Joists/Trusses	100
LE685	68mils (14ga)	0.0713		Fixed/Joists/Trusses	100
LE975	97mils (12ga)	0.1017		Fixed/Joists/Trusses	50
LE547	54mils (16ga)	0.0566	1-1/2 x 3 x 7-1/4	Fixed/Joists/Trusses	100
LE687	68mils (14ga)	0.0713		Fixed/Joists/Trusses	50
LE977	97mils (12ga)	0.1017		Fixed/Joists/Trusses	50
LA543	54mils (16ga)	0.0566	3 x 3 x 3-1/4	Joists/Trusses	100
LA683	68mils (14ga)	0.0713		Joists/Trusses	100
LA973	97mils (12ga)	0.1017		Joists/Trusses	50
LA545	54mils (16ga)	0.0566	3 x 3 x 5-1/2	Joists/Trusses	100
LA685	68mils (14ga)	0.0713		Joists/Trusses	50
LA975	97mils (12ga)	0.1017		Joists/Trusses	50
LA547	54mils (16ga)	0.0566	3 x 3 x 7-1/4	Joists/Trusses	50
LA687	68mils (14ga)	0.0713		Joists/Trusses	50
LA977	97mils (12ga)	0.1017		Joists/Trusses	50

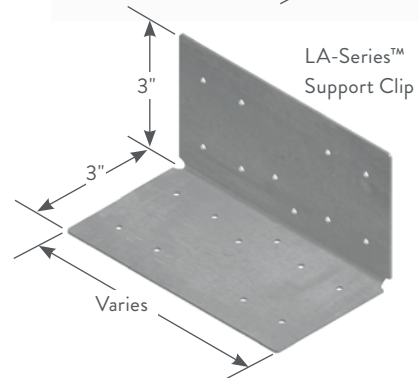
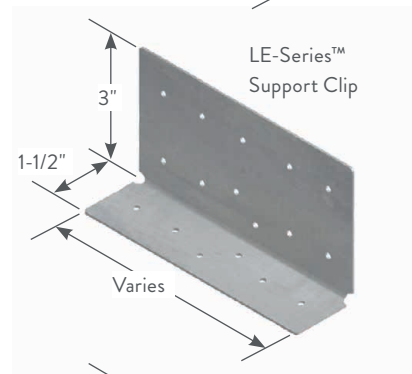
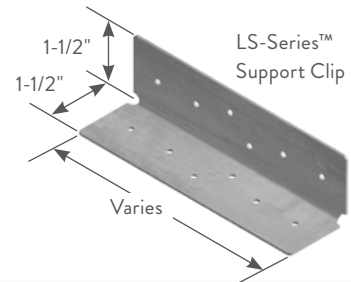

### Allowable Shear Load Table

Product code	No. of screws/leg	Stud Thickness (Yield Strength)				
		20ga (33mils) 33ksi	18ga (43mils) 33ksi	16ga (54mils) 50ksi	14ga (68mils) 50ksi	12ga (97mils) 50ksi
LS543	2	294	438	777	777	777
	4	437	651	1154	1154	1154
LS683	2	294	438	777	777	777
	4	437	651	1154	1154	1154
LS973	2	294	438	777	777	777
	4	437	651	1154	1154	1154
LS545	2	333	496	880	880	880
	4	619	921	1635	1635	1635
LS685	2	333	496	880	880	880
	4	619	921	1635	1635	1635
LS975	2	333	496	880	880	880
	4	619	921	1635	1635	1635
LS547	4	651	968	1718	1718	1718
	6	966	1438	2551	2551	2551
LS687	4	651	968	1718	1718	1718
	6	966	1438	2551	2551	2551
LS977	4	651	968	1718	1718	1718
	6	966	1438	2551	2551	2551
LS549	4	670	997	1768	1768	1768
	6	1007	1498	2658	2658	2658
LS689	4	670	997	1768	1768	1768
	6	1007	1498	2658	2658	2658
LS979	4	670	997	1768	1768	1768
	6	1007	1498	2658	2658	2658
LS541	4	681	1013	1798	1798	1798
	6	1013	1508	2675	2675	2675
LS681	4	681	1013	1798	1798	1798
	6	1013	1508	2675	2675	2675
LS971	4	681	1013	1798	1798	1798
	6	1013	1508	2675	2675	2675
LS5413	4	688	1024	1816	1816	1816
	6	1020	1518	2694	2694	2694
LS6813	4	688	1024	1816	1816	1816
	6	1020	1518	2694	2694	2694
LS9713	4	688	1024	1816	1816	1816
	6	1020	1518	2694	2694	2694

**Notes:**

- 1 Shear values for clips are based on attachment to cold-formed steel members. Attachment to other substrates must be designed separately.
- 2 Place the first two screws in each leg in the outermost screw holes. Place the next two screws (if needed) in center holes next to the CRC holes (diagonal). The next screws (if needed) are placed moving from the outermost holes toward the center, symmetrically.
- 3 Shear values are based on the tilting bearing modes of failure Eq. E4.3.1-1, E4.3.1-2.4. Allowable screw shear is based on a factor of safety of 3.0. #10 screws (0.19" min. diameter) must have minimum ultimate shear strength of 1400 lbs.
- 4 Screws must have three threads exposed after installation.
- 5 It is the responsibility of the design engineer to detail the attachment of clips and verify their capacity meets the application. This table is intended for use by qualified engineers.
- 6 For technical assistance or additional load charts, contact ClarkDietrich at 888-437-3244.

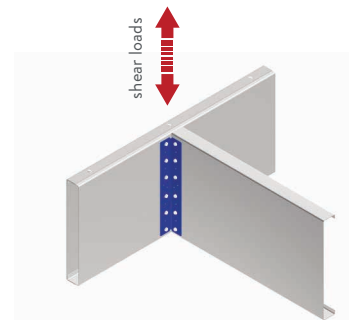

Joist-to-Joist Connections

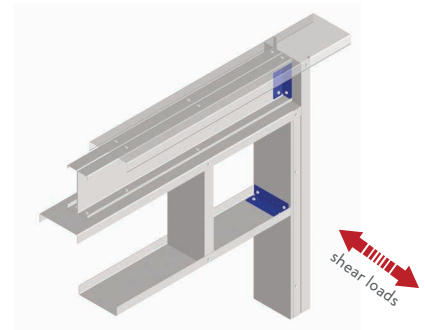

Head-to-Jamb Connections

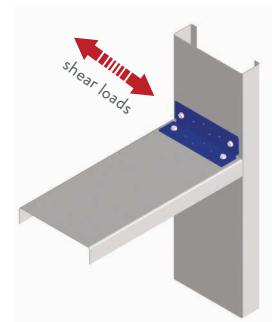

Sill-to-Jamb Connections

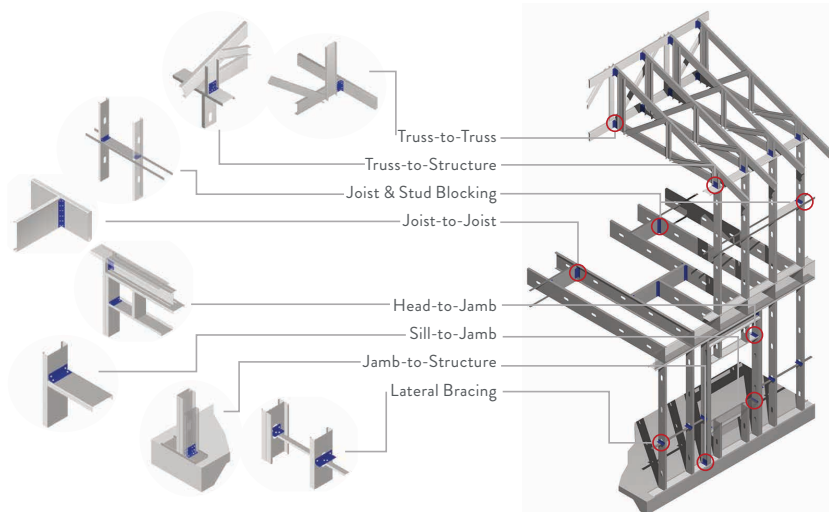

## Extended SwiftClip™ LE-Series

Used in rigid attachments of wall studs to the structure.

ClarkDietrich's Extended SwiftClip™ LE-Series rigid framing clip is used to attach exterior wall studs to the structure of the building. Designed to resist horizontal and vertical loads, the extended rigid clips install easily with screws, powder-actuated fasteners, or welds. This clip is ideal for all medium and large standoff conditions. These clips are unpunched as the specific application will determine the appropriate number and placement of fasteners.

### INSTALLATION

Extended SwiftClip™ LE-Series are attached to cold-formed steel framing members using #10 minimum self-drilling screws. Clips can also be welded to the cold-formed steel framing. Connections to the building frame can be made with powder-actuated fasteners, drill-in concrete anchors or welding. The appropriate type, number and placement of fasteners need to be determined by a design professional and engineer of record.

### PRODUCT DIMENSIONS

- 1-1/2" x 3" legs for up to 20" long clips
- 1-1/2" x 2-5/8" legs + 1/2" return for clips longer than 20"
- All clips: 68 mils (14 gauge) 50ksi, CP90
- LE-Series clips are unpunched
- Lengths available: 16", 18", 20", 24", 30", 36"

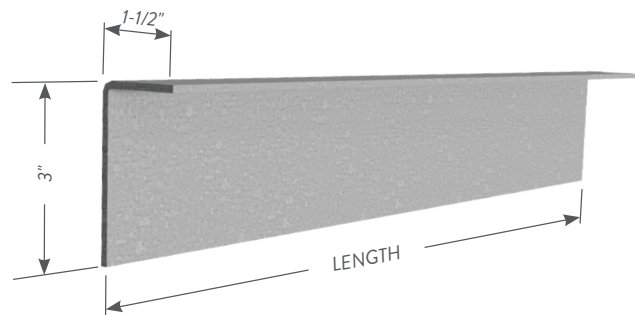

Extended SwiftClip™ LE-Series  
Profile for clips up to 20" long

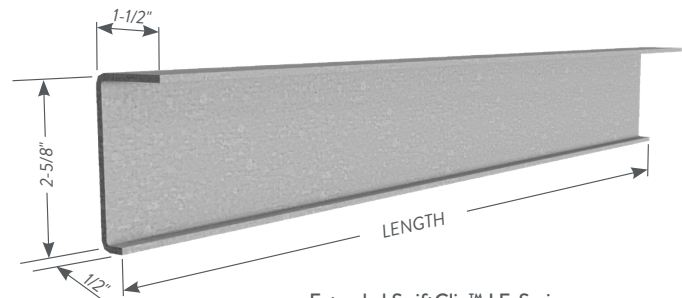

Extended SwiftClip™ LE-Series  
Profile for clips longer than 20"

### Extended SwiftClip™ LE-Series

Product code	Thickness		Size (in)	Packaging Pcs./Box
	Mils (Gauge)	Design thickness (in)		
LE6816	68mils (14ga)	0.0713	1-1/2" x 3" x 16"	10
LE6818			1-1/2" x 3" x 18"	
LE6820			1-1/2" x 3" x 20"	
LE6824	68mils (14ga)	0.0713	1-1/2" x 2-5/8" x 24"	10
LE6830			1-1/2" x 2-5/8" x 30"	
LE6836			1-1/2" x 2-5/8" x 36"	

### Extended SwiftClip™ LE-Series Allowable Loads

Product code	Gross Section Properties									
	Area (in <sup>2</sup> )	I <sub>x</sub> (in <sup>4</sup> )	I <sub>y</sub> (in <sup>4</sup> )	S <sub>x</sub> (in <sup>3</sup> )	S <sub>y</sub> (in <sup>3</sup> )	r <sub>x</sub> (in)	r <sub>y</sub> (in)	x(c) (in)	y(c) (in)	
Extended SwiftClip™ < 20in	0.311	0.304	0.056	0.155	0.046	0.988	0.424	0.281	1.04	
Extended SwiftClip™ > 20in	0.311	0.282	0.054	0.176	0.054	0.952	0.418	0.307	1.02	

#### Notes:

- 1 Extended SwiftClip™ LE-Series intended for axial compression and tension loading.
- 2 I<sub>x</sub>, I<sub>y</sub> are the gross moment of inertia about the X-axis and Y-axis, respectively.
- 3 S<sub>x</sub>, S<sub>y</sub> are the section modulus about the X-axis and Y-axis, respectively.
- 4 r<sub>x</sub>, r<sub>y</sub> are the radius of gyration about the X-axis and Y-axis, respectively.
- 5 x(c), y(c) are the distances of the centroid to the X-axis and Y-axis attachment planes.



## EasyClip™ U-Series™ Clip Angle

Secures U-channel (cold-rolled channel) to framing members for lateral bridging, miscellaneous rigid connections, and multipurpose reinforcing supports.

ClarkDietrich EasyClip™ U-Series™ clip angles are used to secure U-channel to wall studs for lateral bridging or for miscellaneous rigid connections. U-channel is passed through the stud knockout and an EasyClip U-Series clip is screw-attached or welded to provide a rigid connection. Available in a variety of lengths and gauges, EasyClip U-Series clips are prepunched for faster and more accurate fastener placement. U-Series clip angles and U-channel should not be used in bridging applications when the stud width exceeds 6".

### ALTERNATIVE PRODUCTS

FastBridge™ Clip  
 EasyClip™ X-Series™ Clip Angle  
 SwiftClip™ LS-Series™ Support Clip  
 Spazzer® 5400 and Spazzer® 9200 Spacer Bars

### PRODUCT DIMENSIONS

1-1/2" x 1-1/2" x 3-3/8"  
 1-1/2" x 1-1/2" x 5-3/4"  
 1-1/2" x 1-1/2" x 7-3/4"  
 1-1/2" x 1-1/2" x 9-3/4"

### MATERIAL SPECIFICATIONS

**Gauge:** 16 gauge (54mils)  
**Design Thickness:** 0.0566 inches

**Gauge:** 14 gauge (68mils)  
**Design Thickness:** 0.0713 inches

**Gauge:** 12 gauge (97mils)  
**Design Thickness:** 0.1017 inches

**Coating:** G90

**Yield Strength:** 50ksi

**ASTM:** A653/A653M



### INSTALLATION

U-channel is inserted into the stud punchout (as specified by design) and rotated into place. U-Series clip angles are attached horizontally to the outside or hard side of the cold-formed steel (CFS) framing members. The clip must be firmly seated against the web of the U-channel. The clip should not be more than 1/4" less than the cold-formed framing member. U-Series clips are fastened using #10 minimum self-drilling screws driven through the clip holes into the steel framing. Clips may also be welded to the CFS framing.

## EasyClip™ U-Series™ Clip Angles

Product code	Thickness		Size (in)	Packaging Pcs./Bucket
	Mils (Gauge)	Design thickness (in)		
U543	54mils (16ga)	0.0566	1-1/2 x 1-1/2 x 3-3/8	400
U545	54mils (16ga)	0.0566	1-1/2 x 1-1/2 x 5-3/4	200
U547	54mils (16ga)	0.0566	1-1/2 x 1-1/2 x 7-3/4	100
U549	54mils (16ga)	0.0566	1-1/2 x 1-1/2 x 9-3/4	100
U683	68mils (14ga)	0.0713	1-1/2 x 1-1/2 x 3-3/8	200
U685	68mils (14ga)	0.0713	1-1/2 x 1-1/2 x 5-3/4	170
U687	68mils (14ga)	0.0713	1-1/2 x 1-1/2 x 7-3/4	100
U689	68mils (14ga)	0.0713	1-1/2 x 1-1/2 x 9-3/4	100
U973	97mils (12ga)	0.1017	1-1/2 x 1-1/2 x 3-3/8	200
U975	97mils (12ga)	0.1017	1-1/2 x 1-1/2 x 5-3/4	130
U977	97mils (12ga)	0.1017	1-1/2 x 1-1/2 x 7-3/4	100
U979	97mils (12ga)	0.1017	1-1/2 x 1-1/2 x 9-3/4	80

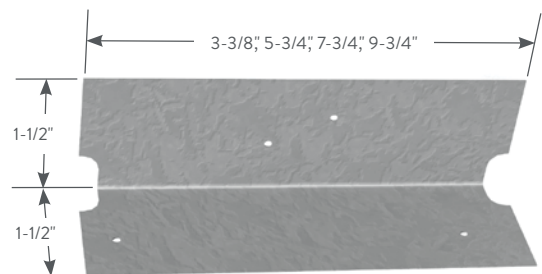

EasyClip U-Series Clip Angle

## EasyClip™ S-Series™ Support Clip

For rigid connection applications not requiring a long leg.

ClarkDietrich EasyClip™ S-Series™ support clips are commonly used for rigid connections in window and door framing, joist, bypass or other miscellaneous connections to secure one framing member to another, or to secure framing members to the structural frame. This high-performance, multi-use utility clip is ideal for corner reinforcements, stair openings, and numerous support applications. Available in a variety of lengths and gauges, EasyClip S-Series clips are prepunched for faster and more accurate fastener placement.

### ALTERNATIVE PRODUCTS

EasyClip™ U-Series™ Clip Angle

EasyClip X-Series™ Clip Angle

EasyClip D-Series™ Anchor Clip

SwiftClip™ LS-Series™ Support Clip

### PRODUCT DIMENSIONS

1-1/2" x 1-1/2" x 3"

1-1/2" x 1-1/2" x 5"

1-1/2" x 1-1/2" x 7"

1-1/2" x 1-1/2" x 9"

1-1/2" x 1-1/2" x 11"

### MATERIAL SPECIFICATIONS

**Gauge:** 16 gauge (54mils)

**Design Thickness:** 0.0566 inches

**Gauge:** 14 gauge (68mils)

**Design Thickness:** 0.0713 inches

**Gauge:** 12 gauge (97mils)

**Design Thickness:** 0.1017 inches

**Coating:** G90

**Yield Strength:** 50ksi

**ASTM:** A653/A653M

### INSTALLATION

EasyClip S-Series support clips are attached to the cold-formed steel (CFS) framing members using #10 minimum self-drilling screws driven through the clip holes into the steel framing. When not filling all holes, install fasteners symmetrically starting at the top and bottom edges and move toward the center of the clip. Clip can also be welded to the CFS framing. Connections to the building frame can be made with powder-actuated fasteners, drill-in concrete anchors or welding. When using the tabular values for a welded clip, provide a full weld to the structure, top to bottom, along the outside of the clip. A 3/4" minimum weld on the outside edge of the 1-1/2" leg is also required to control warping or to hold the clip in place before final welding.

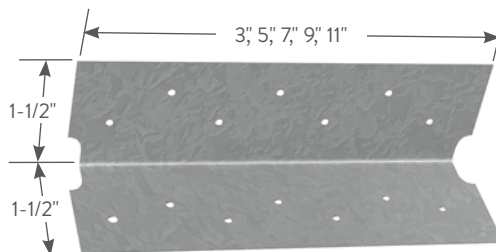

EasyClip S-Series Support Clip

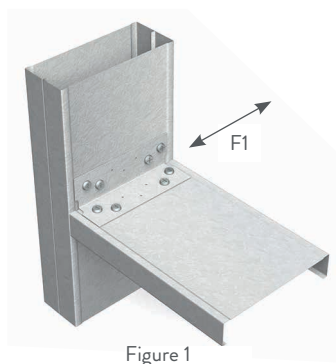
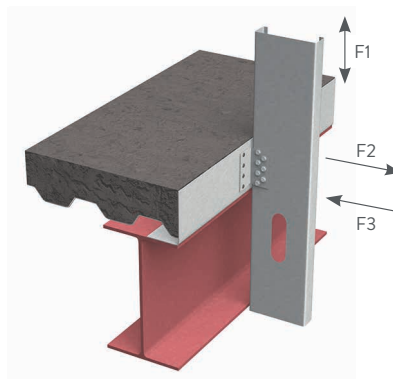
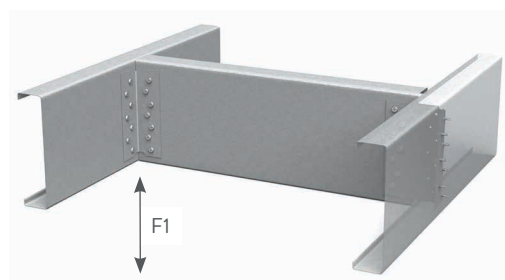

Figure 1



### EasyClip™ S-Series™ Support Clips

Product code	Thickness		Size (in)	Packaging Pcs./ Bucket
	Mils (Gauge)	Design thickness (in)		
S543	54mils (16ga)	0.0566	1-1/2 x 1-1/2 x 3	400
S545	54mils (16ga)	0.0566	1-1/2 x 1-1/2 x 5	200
S547	54mils (16ga)	0.0566	1-1/2 x 1-1/2 x 7	100
S549	54mils (16ga)	0.0566	1-1/2 x 1-1/2 x 9	100
S541	54mils (16ga)	0.0566	1-1/2 x 1-1/2 x 11	100
S683	68mils (14ga)	0.0713	1-1/2 x 1-1/2 x 3	200
S685	68mils (14ga)	0.0713	1-1/2 x 1-1/2 x 5	200
S687	68mils (14ga)	0.0713	1-1/2 x 1-1/2 x 7	100
S689	68mils (14ga)	0.0713	1-1/2 x 1-1/2 x 9	100
S681	68mils (14ga)	0.0713	1-1/2 x 1-1/2 x 11	100
S973	97mils (12ga)	0.1017	1-1/2 x 1-1/2 x 3	200
S975	97mils (12ga)	0.1017	1-1/2 x 1-1/2 x 5	150
S977	97mils (12ga)	0.1017	1-1/2 x 1-1/2 x 7	100
S979	97mils (12ga)	0.1017	1-1/2 x 1-1/2 x 9	80
S971	97mils (12ga)	0.1017	1-1/2 x 1-1/2 x 11	70

### EasyClip™ S-Series™ Support Clips Allowable Clip Capacities (lbs)

USING #10-16 SELF-DRILLING SCREWS

Clip	No. of screws to steel framing (1)	Stud Thickness and Yield Strength								
		20ga (33mils) 33ksi			18ga (43mils) 33ksi			16ga (54mils) 50ksi		
		F1	F2	F3	F1	F2	F3	F1	F2	F3
S543	3	295 (295)	210 (531)	531	437 (437)	210 (788)	788	777 (555)	210 (1195)	1400
	2	317 (317)	354 (354)	354	470 (470)	371 (525)	525	835 (835)	371 (933)	933
S545	5	651 (651)	371 (885)	885	965 (965)	371 (1313)	1313	1716 (1460)	371 (2105)	2333
	4	653 (653)	531 (708)	708	969 (969)	531 (1050)	1050	1722 (1722)	531 (1867)	1867
S547	7	1029 (1029)	531 (1239)	1239	1526 (1526)	531 (1838)	1838	2712 (2456)	531 (3015)	3267
	4	679 (679)	692 (708)	708	1007 (1007)	692 (1050)	1050	1790 (1790)	692 (1867)	1867
S549	9	1408 (1408)	692 (1593)	1593	2090 (2090)	692 (2363)	2363	3714 (3452)	692 (3925)	4200
	6	1015 (1015)	852 (1062)	1062	1505 (1505)	852 (1576)	1576	2675 (2675)	852 (2800)	2800
S541	11	1785 (1785)	852 (1947)	1947	2648 (2648)	852 (2889)	2889	4706 (4432)	852 (4835)	5133
	3	295 (295)	333 (531)	531	437 (437)	333 (788)	788	777 (699)	333 (1400)	1400
S683	2	317 (317)	354 (354)	354	470 (470)	525 (525)	525	835 (835)	587 (933)	933
	5	651 (651)	587 (885)	885	965 (965)	587 (1313)	1313	1716 (1716)	587 (2333)	2333
S685	4	653 (653)	708 (708)	708	969 (969)	841 (1050)	1050	1722 (1722)	841 (1867)	1867
	7	1029 (1029)	841 (1239)	1239	1526 (1526)	841 (1838)	1838	2712 (2712)	841 (3267)	3267
S687	4	679 (679)	708 (708)	708	1007 (1007)	1050 (1050)	1050	1790 (1790)	1095 (1867)	1867
	9	1408 (1408)	1095 (1593)	1593	2090 (2090)	1095 (2363)	2363	3714 (3714)	1095 (4200)	4200
S689	6	1015 (1015)	1062 (1062)	1062	1505 (1505)	1349 (1576)	1576	2675 (2675)	1349 (2800)	2800
	11	1785 (1785)	1349 (1947)	1947	2648 (2648)	1349 (2889)	2889	4706 (4706)	1349 (5133)	5133
S681	3	295 (295)	531 (531)	531	437 (437)	679 (788)	788	777 (777)	679 (1400)	1400
	2	317 (317)	354 (354)	354	470 (470)	525 (525)	525	835 (835)	933 (933)	933
S973	5	651 (651)	885 (885)	885	965 (965)	1196 (1313)	1313	1716 (1716)	1196 (2333)	2333
	4	653 (653)	708 (708)	708	969 (969)	1050 (1050)	1050	1722 (1722)	1713 (1867)	1867
S975	7	1029 (1029)	1239 (1239)	1239	1526 (1526)	1713 (1838)	1838	2712 (2712)	1713 (3267)	3267
	4	679 (679)	708 (708)	708	1007 (1007)	1050 (1050)	1050	1790 (1790)	1867 (1867)	1867
S977	9	1408 (1408)	1593 (1593)	1593	2090 (2090)	2229 (2363)	2363	3714 (3714)	2229 (4200)	4200
	6	1015 (1015)	1062 (1062)	1062	1505 (1505)	1576 (1576)	1576	2675 (2675)	2746 (2800)	2800
S979	11	1785 (1785)	1947 (1947)	1947	2648 (2648)	2746 (2889)	2889	4706 (4706)	2746 (5133)	5133
	3	295 (295)	531 (531)	531	437 (437)	679 (788)	788	777 (777)	679 (1400)	1400
S971	2	317 (317)	354 (354)	354	470 (470)	525 (525)	525	835 (835)	933 (933)	933
	5	651 (651)	885 (885)	885	965 (965)	1196 (1313)	1313	1716 (1716)	1196 (2333)	2333
S977	4	653 (653)	708 (708)	708	969 (969)	1050 (1050)	1050	1722 (1722)	1713 (1867)	1867
	7	1029 (1029)	1239 (1239)	1239	1526 (1526)	1713 (1838)	1838	2712 (2712)	1713 (3267)	3267
S979	4	679 (679)	708 (708)	708	1007 (1007)	1050 (1050)	1050	1790 (1790)	1867 (1867)	1867
	9	1408 (1408)	1593 (1593)	1593	2090 (2090)	2229 (2363)	2363	3714 (3714)	2229 (4200)	4200
S971	6	1015 (1015)	1062 (1062)	1062	1505 (1505)	1576 (1576)	1576	2675 (2675)	2746 (2800)	2800
	11	1785 (1785)	1947 (1947)	1947	2648 (2648)	2746 (2889)	2889	4706 (4706)	2746 (5133)	5133

**Notes:**

**Screw Capacity Notes:**

- The tabulated value indicates the number of screws in a single clip leg attached to the cold-formed steel (CFS) framing.
- Screws shall be attached in a symmetric manner, starting at the outside holes and moving to the center. Reference Figure 1 on opposite page.
- The allowable values for F1 are based only on the shear capacity of the clip leg attached to the CFS framing. The capacity of the attachment to other materials and structures must be checked separately.
- The allowable values for F2 assume mechanical fasteners are attached to the structure, and are along the vertical centerline of the clip leg. Mechanical fasteners to other materials and structures must be checked separately.
- The screw diameter must be 0.19" (min.) for #10 screws.
- The ultimate screw shear strength must be a minimum of 1400 lbs for #10 screws.
- When clips have combinations of F1, F2, and F3, use a linear interaction for combinations of F1 and F3, and a squared interaction for combinations of F1 and F2.

- Screws must be long enough so that at least three exposed threads are visible after installation.
- Allowable loads have not been increased 33% for wind or seismic.
- For connections made to 14 gauge (68mils) and 12 gauge (97mils), use the tabulated values for 16 gauge (54mils), 50ksi.
- It is the responsibility of the design professional to detail the drawings for proper clip attachment.
- Contact ClarkDietrich at 888-437-3244 for technical assistance.

**Weld Capacity Notes:**

- F1 and F2 values in parentheses are maximum shear and tension capacities when the clips are welded to the base structure (min 3/16" – 36ksi steel).
- Listed weld capacities are computed assuming an E70XX welding rod or wire.
- The clips are to be welded to the structure along the back corner and along the complete length of the clip. When secondary welds are used to hold the clip in place, they are not used in capacity calculations.

## EasyClip™ A-Series™ End Clip

For knee-wall connections or to reinforce jamb stud connections at the primary frame.

ClarkDietrich EasyClip™ A-Series™ end clips are most commonly used to reinforce connections in knee-wall applications or to reinforce jamb stud connections to the primary frame. These clips are unpunched as the specific application will determine the appropriate number and placement of fasteners.

### ALTERNATIVE PRODUCTS

- EasyClip™ D-Series™ Anchor Clip
- EasyClip T-Series™ Tall Anchor Clip
- SwiftClip™ LA-Series™ Support Clip

### PRODUCT DIMENSIONS

- 3" x 3" x 3"
- 3" x 3" x 6"

### MATERIAL SPECIFICATIONS

- Gauge:** 16 gauge (54mils)
- Design Thickness:** 0.0566 inches
- Gauge:** 14 gauge (68mils)
- Design Thickness:** 0.0713 inches
- Gauge:** 12 gauge (97mils)
- Design Thickness:** 0.1017 inches
- Coating:** G90
- Yield Strength:** 50ksi
- ASTM:** A653/A653M

### INSTALLATION

EasyClip A-Series end clips are attached to cold-formed steel (CFS) framing members using #10 minimum self-drilling screws. Clips can also be welded to the CFS framing. Connections to the building frame can be made with powder-actuated fasteners, drill-in concrete anchors or welding. When using the tabular values for a welded clip, provide a full weld to the structure, top to bottom, along the outside of the clip. A 3/4" minimum weld to the outside edge of the 3" leg is also recommended to control warping or to hold the clip in place before final welding.

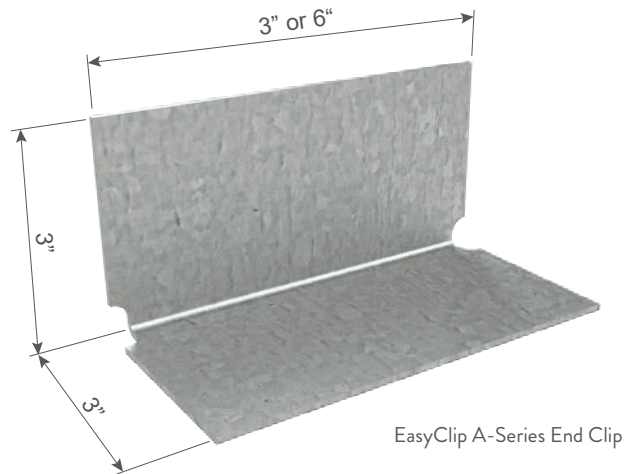

EasyClip A-Series End Clip

### EasyClip™ A-Series™ End Clips

Product code	Thickness		Size (in)	Packaging Pcs./Bucket
	Mils (Gauge)	Design thickness (in)		
A543	54mils (16ga)	0.0566	3 x 3 x 3	100
A546	54mils (16ga)	0.0566	3 x 3 x 6	100
A683	68mils (14ga)	0.0713	3 x 3 x 3	100
A686	68mils (14ga)	0.0713	3 x 3 x 6	100
A973	97mils (12ga)	0.1017	3 x 3 x 3	100
A976	97mils (12ga)	0.1017	3 x 3 x 6	50

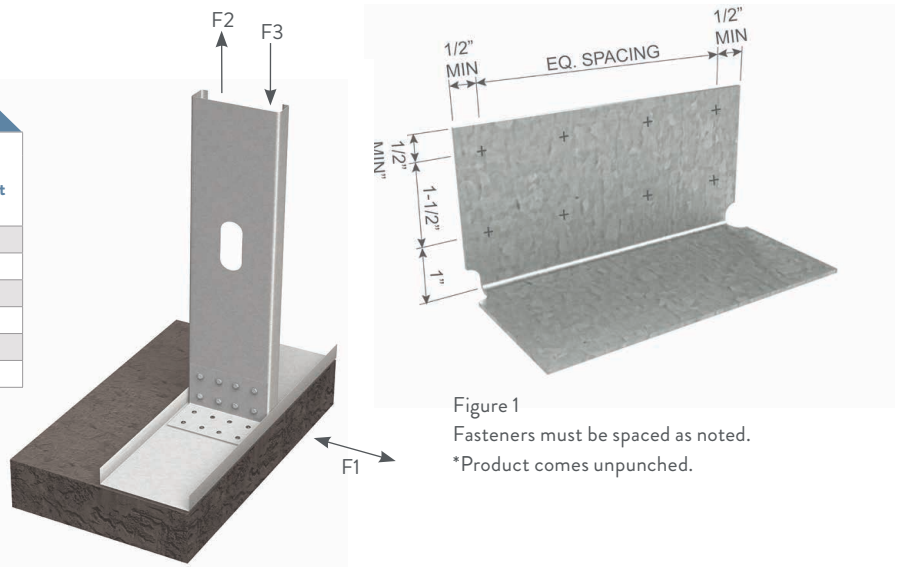

Figure 1  
Fasteners must be spaced as noted.  
\*Product comes unpunched.



## EasyClip™ A-Series™ End Clips Allowable Clip Capacities (lbs)

USING #10-16  
SELF-DRILLING SCREWS

Clip	No. of screws to steel framing (1)	Stud Thickness and Yield Strength								
		20ga (33mils) 33ksi			18ga (43mils) 33ksi			16ga (54mils) 50ksi		
		F1	F2	F3	F1	F2	F3	F1	F2	F3
A543	4	354 (354)	120 (708)	708	525 (375)	120 (1050)	1050	775 (375)	120 (1365)	1381
	6	531 (375)	120 (1062)	1062	775 (375)	120 (1365)	1381	775 (375)	120 (1365)	1381
A546	6	531 (531)	241 (1062)	1062	788 (788)	241 (1576)	1576	1400 (1355)	241 (2730)	2800
	8	708 (708)	241 (1416)	1416	1050 (1050)	241 (2101)	2101	1867 (1355)	241 (2730)	3452
	10	885 (885)	241 (1770)	1770	1313 (1313)	241 (2626)	2626	2333 (1355)	241 (2730)	3452
	12	1062 (1062)	241 (2124)	2124	1576 (1355)	241 (2730)	3151	2634 (1355)	241 (2730)	3452
A683	4	354 (354)	190 (708)	708	525 (472)	190 (1050)	1050	933 (472)	190 (1718)	1867
	6	531 (472)	190 (1062)	1062	788 (472)	190 (1576)	1576	1149 (472)	190 (1718)	2353
A686	6	531 (531)	381 (1062)	1062	788 (788)	381 (1576)	1576	1400 (1400)	381 (2800)	2800
	8	708 (708)	381 (1416)	1416	1050 (1050)	381 (2101)	2101	1867 (1705)	381 (3436)	3733
	10	885 (885)	381 (1770)	1770	1313 (1313)	381 (2626)	2626	2333 (1705)	381 (3436)	4667
	12	1062 (1062)	381 (2124)	2124	1576 (1576)	381 (3151)	3151	2800 (1705)	381 (3436)	5600
A973	4	354 (354)	388 (708)	708	525 (525)	388 (1050)	1050	933 (673)	388 (1867)	1867
	6	531 (531)	388 (1062)	1062	788 (673)	388 (1576)	1576	1400 (673)	388 (2451)	2800
A976	6	531 (531)	775 (1062)	1062	788 (788)	775 (1576)	1576	1400 (1400)	775 (2800)	2800
	8	708 (708)	775 (1416)	1416	1050 (1050)	775 (2101)	2101	1867 (1867)	775 (3733)	3733
	10	885 (885)	775 (1770)	1770	1313 (1313)	775 (2626)	2626	2333 (2333)	775 (4667)	4667
	12	1062 (1062)	775 (2124)	2124	1576 (1576)	775 (3151)	3151	2800 (2432)	775 (4903)	5600

**Notes:**

**Screw Capacity Notes:**

- The tabulated value indicates the number of screws in a single clip leg attached to the cold-formed steel (CFS) framing.
- Screws shall be attached in a symmetric manner starting at the top and bottom moving to the center, see Figure 1 opposite page.
- The allowable values for F1 are based only on the shear capacity of the clip leg attached to the CFS framing. The capacity of the attachment to other materials and structures must be checked separately.
- The allowable values for F2 assume mechanical fasteners are attached to the structure and are located no more than 1" away from the angle bend. Mechanical fasteners to other materials and structures must be checked separately.
- This table is intended for use by qualified engineers only. It is the responsibility of the engineer to verify that the tabulated values apply to a specific connection application.
- When clips have combinations of F1, F2 and F3, use a linear interaction for combinations of F1 and F3, and a squared interaction for combinations of F1 and F2.

7 Allowable loads have not been increased 33% for wind or seismic.

8 For connections made to 14 gauge (68mils) and 12 gauge (97mils), use the tabulated values for 16 gauge (54mils), 50ksi.

9 It is the responsibility of the design professional to detail the drawings for proper clip attachment.

10 Contact ClarkDietrich at 888-437-3244 for technical assistance.

**Weld Capacity Notes:**

- F1 and F2 values in parentheses are maximum shear and tension capacities when the clips are welded to the base structure (min. 3/16" – 36ksi steel).
- Listed weld capacities are computed assuming an E70XX welding rod or wire.
- The clips are to be welded to the structure along the back corner along the complete length of the clip. When secondary welds are used to hold the clip in place, they are not used in capacity calculations. 3/4" min. secondary weld as required to control warping or to hold clip in place before final welding.

### TYPICAL CONSTRUCTION DETAILS

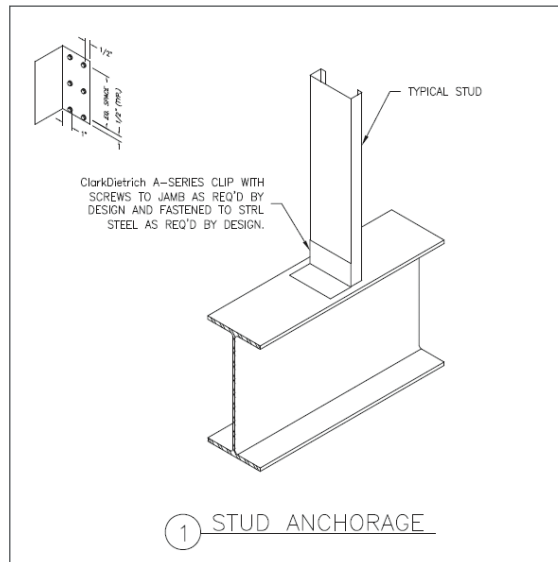
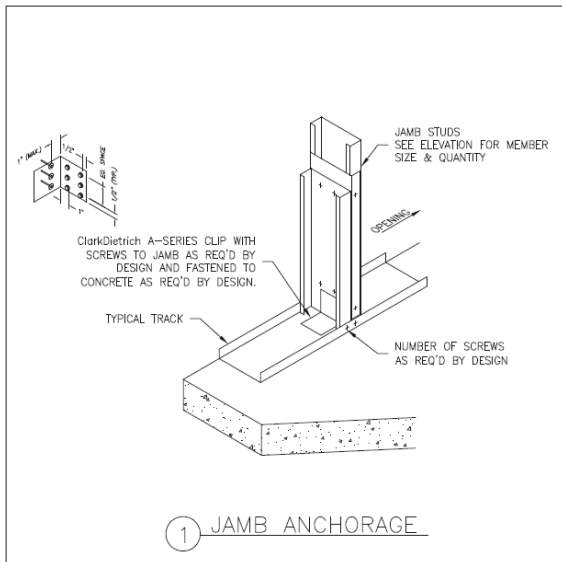

Visit our CAD Library at [clarkdietrich.com](http://clarkdietrich.com) to view or download construction details in .dwg, .dxf, and .pdf formats.

## EasyClip™ D-Series™ Anchor Clip/EasyClip™ T-Series™ Tall Anchor Clip

Cost-effective tie-down solutions for knee walls, shearwalls and truss connections.

ClarkDietrich EasyClip™ D-Series™ anchor clips and T-Series™ tall anchor clips are high-performance, cost-effective solutions for knee wall-to-foundation connections, light-duty shearwall-to-foundation connections and truss-to-wall connections. These multi-application clips feature reinforced stiffening ribs that provide superior design values for maximum performance. The EasyClip D-Series anchor clips and T-Series tall anchor clips are designed to resist horizontal, torsional and vertical (uplift) loads. These clips are prepunched with a series of attachment holes including anchor bolt, Kwik-Con and screw holes, for efficient and accurate fastener placement.

### ALTERNATIVE PRODUCTS

- EasyClip™ A-Series™ End Clip
- SwiftClip™ LA-Series™ Support Clip
- Uni-Clip™

### PRODUCT DIMENSIONS

#### EasyClip D-Series:

- 2" x 2" x 3-1/2"
- 2" x 2" x 5-1/2"

#### EasyClip T-Series:

- 2" x 4" x 3-1/2"
- 2" x 4" x 5-1/2"

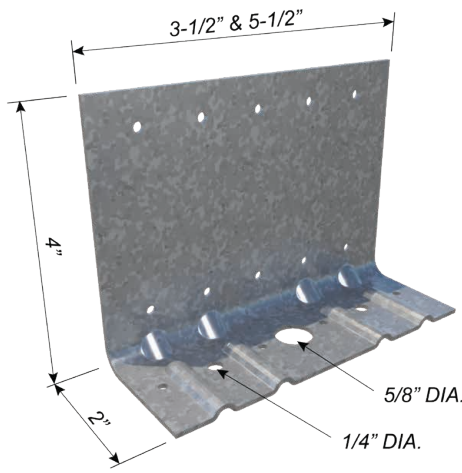

EasyClip T-Series Tall Anchor Clip

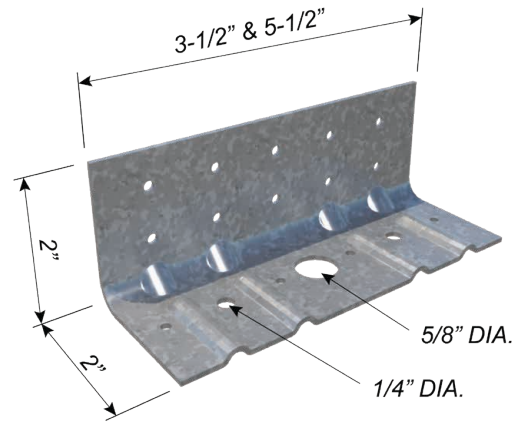

EasyClip D-Series Anchor Clip

### MATERIAL SPECIFICATIONS

- Gauge:** 14 gauge (68mils)
- Design Thickness:** 0.0713 inches
- Gauge:** 12 gauge (97mils)
- Design Thickness:** 0.1017 inches
- Coating:** G90
- Yield Strength:** 50ksi
- ASTM:** A653/A653M

### INSTALLATION

Install EasyClip D-Series and T-Series anchor clips by attaching the screw hole-only leg to the web of the stud, joist, rafter or track with the applicable number of fasteners (screws or welds). Secure bottom leg (anchor bolt hole) to structure using prepunched holes provided with appropriate fastener type and number of fasteners according to design based on load requirements.

## EasyClip™ D-Series™ Anchor Clips and T-Series™ Tall Anchor Clips

Product code	Thickness		Size (in)	Packaging Pcs./Bucket
	Mils (Gauge)	Design thickness (in)		
D683	68mils (14ga)	0.0713	2 x 2 x 3-1/2	40
T683	68mils (14ga)	0.0713	2 x 4 x 3-1/2	40
D685	68mils (14ga)	0.0713	2 x 2 x 5-1/2	40
T685	68mils (14ga)	0.0713	2 x 4 x 5-1/2	40
D973	97mils (12ga)	0.1017	2 x 2 x 3-1/2	40
T973	97mils (12ga)	0.1017	2 x 4 x 3-1/2	40
D975	97mils (12ga)	0.1017	2 x 2 x 5-1/2	40
T975	97mils (12ga)	0.1017	2 x 4 x 5-1/2	40

EasyClip™ D-Series™ Anchor Clips and T-Series™ Tall Anchor Clips		ALLOWABLE LOADS (LBS)								
Product code	Stud thickness Mils (Gauge)	Stud Fy (ksi)	F1 (Shear), (lbs)			F2 (Tension), (lbs)			M (Moment), (in-lbs)	
			Number of #10-16 Screws to Stud						Kwik-Cons/ screws	1/2" Dia. Kwik-Bolts
			4	6	10	4	6	10		
D683	33mils (20ga)	33	374	466	664*	444	444	444	1418	1068
	43mils (18ga)	33	556	692*	986*#	444	444	444	1675	1068
	54mils (16ga)	33	783*	974*#	1389*#	444	444	444	1675	1068
	54mils (16ga)	50	1107*#	1377*#	1962*#	444	444	444	1675	1068
D973	33mils (20ga)	33	374	466	664	560	840	889	1418	1418
	43mils (18ga)	33	556	692	986*	832	889	889	2107*	2054
	54mils (16ga)	33	783	974*	1389*#	889	889	889	2447*	2054
	54mils (16ga)	50	1107*	1377*#	1962*#	889	889	889	2447*	2054
T683	33mils (20ga)	33	280	383	604	444	444	444	1787*	1106
	43mils (18ga)	33	416	569	897	444	444	444	2072*	1106
	54mils (16ga)	33	586	802*	1264*#	444	444	444	2072*	1106
	54mils (16ga)	50	828*	1133*#	1786*#	444	444	444	2072*	1106
T973	33mils (20ga)	33	280	383	604	560	840	889	1787*	1787
	43mils (18ga)	33	416	569	897	832	889	889	2527*	2110
	54mils (16ga)	33	586	802	1264*	889	889	889	2527*	2110
	54mils (16ga)	50	828	1133*	1786*#	889	889	889	2527*	2110
D685	33mils (20ga)	33	456	599	879	560	698	698	2019	2019
	43mils (18ga)	33	677	890	1306*	698	698	698	2865*	2234
	54mils (16ga)	33	954	1254*	1839*#	698	698	698	2865*	2234
	54mils (16ga)	50	1348*	1772*	2599*#%	698	698	698	2865*	2234
D975	33mils (20ga)	33	456	599	879	560	840	889	2019	2019
	43mils (18ga)	33	677	890	1306*	832	889	889	2999*	2999
	54mils (16ga)	33	954	1254*	1839*#	889	889	889	3477*	3167
	54mils (16ga)	50	1348*	1772*	2599*#%	889	889	889	3477*	3167
T685	33mils (20ga)	33	337	445	678	560	698	698	2298*	1968
	43mils (18ga)	33	501	661	1008*	698	698	698	3415*	1968
	54mils (16ga)	33	706	931	1420*	698	698	698	3509*	1968
	54mils (16ga)	50	997*	1316*	2006*#%	698	698	698	3509*	1968
T975	33mils (20ga)	33	337	445	678	560	840	889	2298*	2298
	43mils (18ga)	33	501	661	1008*	832	889	889	3415*	3059
	54mils (16ga)	33	706	931	1420*	889	889	889	4416*	3059
	54mils (16ga)	50	997*	1316*	2006*#%	889	889	889	4416*	3059

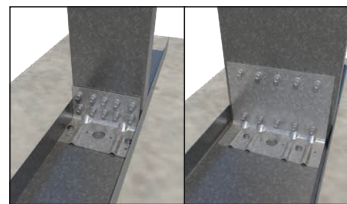
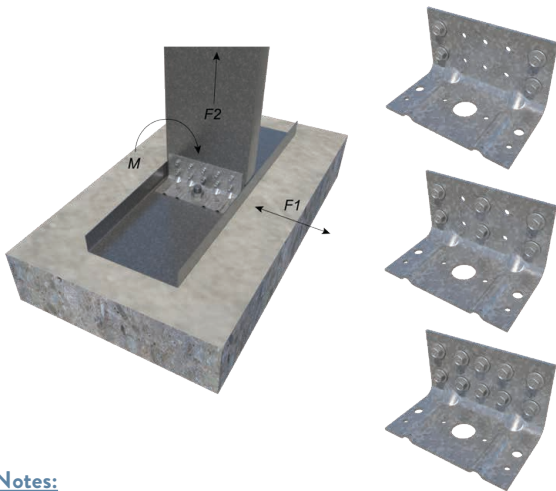

Figure 1 Kwik-Cons

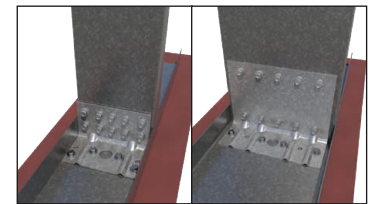

Figure 2 #12-24 screws

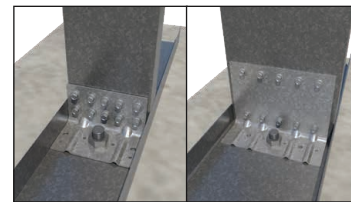

Figure 3 Kwik-Bolts

**Notes:**

- Capacities listed in the table/notes assume that no load reductions are required for spacing or edge distance of Kwik-Cons, screws, or Kwik-Bolts.
- An "\*" in the shear column indicates that the shear capacity is limited to 642 lbs for D683 and T683 clips, 917 lbs for D973 and T973 clips, and 994 lbs for D685, D975, T685, and T975 clips when using 1/4" x 1-3/4" Hilti® Kwik-Cons to 3000psi concrete as shown in Figure 1.
- A "#" in the shear column indicates that the shear capacity is limited to 963 lbs for D683 and T683 clips, 1374 lbs for D973 and T973 clips, and 1816 lbs for D685, D975, T685, and T975 clips when using #12-24 self-tapping screws to 3/16" A36 steel as shown in Figure 2.
- A "%" in the shear column indicates that the shear capacity is limited to 1970 lbs when using 1/2" x 2-1/4" Hilti Kwik-Bolts to 3000psi concrete as shown in Figure 3.
- A "\*" in the moment column indicates that moment capacity is limited to 1706 in.-lb. for 3" clips, and 2231 in.-lb. for 5" clips when using 1/4" x 1-3/4" Hilti-Cons to 3000psi concrete as shown in Figure 1.
- Tabulated moment capacity is limited to a serviceability of 0.02 radians, or 1.1 degrees of rotation at the connection.
- For 20 and 18 gauge studs, the tabulated moment capacity is based on 18 gauge minimum base track, with (1) #10-16 screw at each track leg to stud flange. For 16 gauge and heavier studs, the base track shall be 14 gauge minimum.
- Tabulated moment capacity is based on a stud to clip connection using (6) #10-16 screws.
- For single-bolt connections, rotational restraint must be provided by the base track.
- For 14 gauge (68mils) and 12 gauge (97mils), use the tabulated values for 16 gauge (54mils), 50ksi studs.
- It is the responsibility of the designer to properly detail connections on the contract drawings.
- Use a linear interaction equation for connections involving any combination of F1, F2, and M.
- Hilti is a registered trademark of Hilti Aktiengesellschaft Corporation.

## FastBridge™ Clip

Secures U-channel (cold-rolled channel) framing members for load-bearing or curtain wall applications.

The ClarkDietrich FastBridge clip is used to secure U-Channel or Cold-Rolled Channel (CRC) to structural or non-structural wall studs when used in load-bearing, curtain wall or drywall framing applications. The wall stud friction fit design allows for as little as one screw for the connection to the U-channel.

The FastBridge clip is a stiffened, G90 galvanized steel clip that's tested and designed to facilitate the rapid, efficient installation of 1-1/2" U-channel lateral bracing for exterior curtain wall framing, load-bearing walls or interior partitions constructed of structural or non-structural studs.

- FB33 for use with 20ga-16ga structural studs or ProSTUD® Drywall Studs
- FB43 for use with 20ga-16ga structural studs
- FB68 for use with 16ga-12ga structural studs

### MATERIAL SPECIFICATIONS

**Gauge:** 20 gauge STR (33mils)

**Design Thickness:** 0.0346 inches

**Gauge:** 18 gauge (43mils)

**Design Thickness:** 0.0451 inches

**Gauge:** 14 gauge (68mils)

**Design Thickness:** 0.0713 inches

**Coating:** G90

**ASTM:** A653

### ALTERNATIVE PRODUCTS

- Spazzer® 5400 and 9200 Bridging Bar
- U-Channel with SwiftClip™ LS-Series™ Support Clip
- EasyClip™ U-Series™ Clips

### INSTALLATION

U-Channel is inserted into the stud punchout (spacing as specified by design) and rotated into place (leg down). Place the FastBridge Clip inside the punchout (stiffened wings down) and twist allowing the friction fit design to hold the clip into place. The clip must be firmly seated over the top web of the U-channel. FastBridge clips are fastened using #10 self-drilling screws driven through the clip hole into the U-channel. More than one screw may be needed depending on design. The FastBridge clip should not be used in studs over 8" wide.



### FastBridge™ Clip Angles (FB)

Product code	Thickness			Knockout size	Packaging pcs./bucket	
	Mils (Gauge)	Yield strength	Design thickness (in)			
FB33	33mils (20ga STR)	33ksi	0.0346	0.0329	1-1/2"	200
FB43	43mils (18ga)	50ksi	0.0451	0.0428	1-1/2"	200
FB68	68mils (14ga)	50ksi	0.0713	0.0677	1-1/2"	200

U.S. Patent No. D692,746 and Canadian Patent No. 152,547

## FastBridge™ Clip Angles (FB43) Allowable Clip Capacities (lbs)

Product code	No. of screws to steel framing	Stud depth (in)	Allowable connector capacity	Stud Thickness and Yield Strength		
				33mils (20ga)	43mils (18ga)	54mils (16ga)
FB43	1	3.625	Axial Brace Stiffness (lbs/in)	1140	1330	2270
	2			1220	1480	2270
	1		Axial Brace Strength (lbs)	178	210	273
	2			275	318	424
	1		Torsional Moment (in-lbs)	148	182	208
	2			331	430	556
FB43	1	4.00	Axial Brace Stiffness (lbs/in)	1030	1460	2170
	2			1190	1520	3030
	1		Axial Brace Strength (lbs)	191	213	263
	2			283	321	426
	1		Torsional Moment (in-lbs)	137	182	234
	2			403	403	498
FB43	1	6.00	Axial Brace Stiffness (lbs/in)	790	990	1730
	2			990	1160	1930
	1		Axial Brace Strength (lbs)	107	214	290
	2			263	324	450
	1		Torsional Moment (in-lbs)	166	170	172
	2			296	406	567
FB43	1	8.00	Axial Brace Stiffness (lbs/in)	—	750	1910
	2			—	750	1960
	1		Axial Brace Strength (lbs)	—	212	272
	2			—	302	438
	1		Torsional Moment (in-lbs)	—	152	343
	2			—	461	526

## FastBridge™ Clip Angles (FB68) Allowable Clip Capacities (lbs)

Product code	No. of screws to steel framing	Stud depth (in)	Allowable connector capacity	Stud Thickness and Yield Strength		
				54mils (16ga)	68mils (14ga)	97mils (12ga)
FB68	1	3.625	Axial Brace Stiffness (lbs/in)	3410	4410	6270
	2			4010	6880	7585
	1		Axial Brace Strength (lbs)	465	520	573
	2			665	732	823
	1		Torsional Moment (in-lbs)	332	440	435
	2			735	894	1150
FB68	1	4.00	Axial Brace Stiffness (lbs/in)	3060	3440	6740
	2			3710	4670	8960
	1		Axial Brace Strength (lbs)	475	505	505
	2			676	752	878
	1		Torsional Moment (in-lbs)	382	462	564
	2			724	802	938
FB68	1	6.00	Axial Brace Stiffness (lbs/in)	2270	3240	3200
	2			2710	3870	3530
	1		Axial Brace Strength (lbs)	468	506	515
	2			682	788	885
	1		Torsional Moment (in-lbs)	294	412	670
	2			686	758	1004
FB68	1	8.00	Axial Brace Stiffness (lbs/in)	1940	2500	2530
	2			1960	2810	3015
	1		Axial Brace Strength (lbs)	463	510	517
	2			637	747	898
	1		Torsional Moment (in-lbs)	310	512	674
	2			682	788	963

**Notes:**

- Allowable loads are based on the use of cold-formed steel studs with a minimum yield strength of  $F_y=33$ ksi and tensile strength of  $F_u=45$ ksi for 43mils (18ga) or thinner; and a minimum yield strength  $F_y=50$ ksi and tensile strength  $F_u=65$ ksi for 54mils (16ga) or thicker.
- Allowable loads are based on 54mils (16ga) u-channel bridging with a minimum yield strength  $F_y=33$ ksi and tensile strength  $F_u=45$ ksi.
- Allowable loads are for the bridging connection only. The strength and serviceability of the framing members is the responsibility of the designer.
- Allowable loads are based on #10 self-drilling screws with a nominal diameter of 0.190 in. and a washer diameter of 0.375 in. Fasteners must have a minimum nominal shear strength of  $P_{ss}=1718$  lbs and a nominal tensile strength of  $P_{ts}=2654$  lbs.
- Allowable loads may not be increased for wind or seismic load.
- Allowable loads are for use when using ASD design methodology. For LRFD loads, multiply ASD allowable loads by 1.6.
- Allowable brace loads are based on ultimate test loads divided by a safety factor. Serviceability limits are not considered. Brace stiffness requirements are detailed in AISI S100 Section D3.3.
- Axial brace stiffness values apply to both ASD and LRFD designs.

## H-Series™ Universal Header Hanger

Connect box headers to jambs or beams to columns.

The H-Series™ universal header hanger is used to connect box headers to jambs or beams to columns and transfer large vertical loads. This universal hanger is designed so one part can be used for either side of the connection. The hanger also features a support tab for proper alignment and easy installation.

The H-Series hanger is also prepunched with a series of round, square and triangle holes to ensure proper fastener placement for specified loads.

### ALTERNATIVE PRODUCTS

HDS® Framing System, HDSC Header Bracket, GP-Series™ Unpunched Gusset Plate

### PRODUCT DIMENSIONS

6" x 8-1/2"

### MATERIAL SPECIFICATIONS

**Gauge:** 18 gauge (43mils)

**Design Thickness:** 0.0451 inches

**Gauge:** 16 gauge (54mils)

**Design Thickness:** 0.0566 inches

**Gauge:** 14 gauge (68mils)

**Design Thickness:** 0.0713 inches

**Coating:** G90

**Yield Strength:** 33ksi for 18 gauge

50ksi for 14 & 16 gauge

**ASTM:** A653/A653M

### INSTALLATION

Install the H-Series universal header hanger to the jamb studs with the required number of screws as needed to achieve required loading. Normally two connectors are required, one on each side of the header.

Position header on header support tabs and secure header to header hanger with number of fasteners required by design.

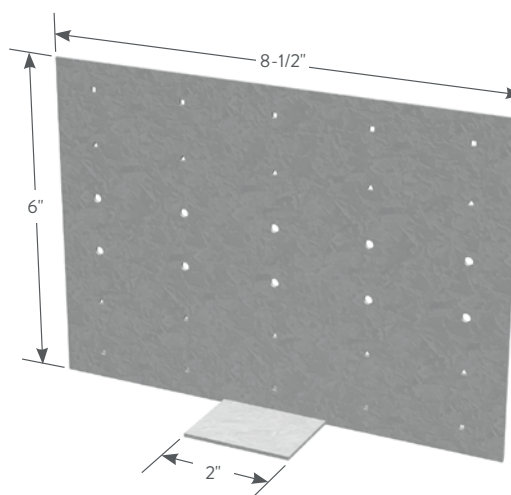

H-Series Universal Header Hanger

## H-Series™ Universal Header Hangers

Product code	Thickness		Size (in)	Packaging Pcs./Bucket
	Mils (Gauge)	Design thickness (in)		
H436	43mils (18ga)	0.0451	6 x 8-1/2	50
H546	54mils (16ga)	0.0566	6 x 8-1/2	50
H686	68mils (14ga)	0.0713	6 x 8-1/2	50

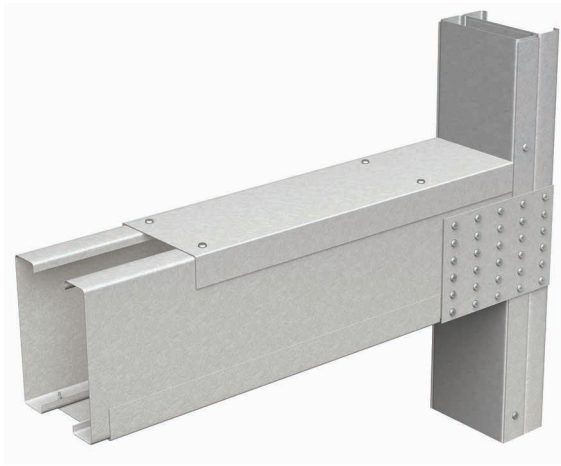

SCREW OPTIONS



(10) Screws  
(6) at Header (4) at Jamb



(20) Screws  
(12) at Header (8) at Jamb



(30) Screws  
(18) at Header (12) at Jamb

Allowable Loading Chart for Single Connectors

Connector	Framing Mils (Gauge)	Framing Fy (ksi)	10 Screws		20 Screws		30 Screws	
			Jamb capacity	Header capacity	Jamb capacity	Header capacity	Jamb capacity	Header capacity
H436 Using #10"-16" Screws	33mils (20ga)	33	561	307	1121	507	1361	637
	43mils (18ga)	33	832	455	1361	753	1361	945
	54mils (16ga)	33	832	455	1361	753	1361	945
		50	832	455	1361	753	1361	945
	68mils (14ga)	33	832	455	1361	753	1361	945
		50	832	455	1361	753	1361	945
97mils (12ga)	33	832	455	1361	753	1361	945	
	50	832	455	1361	753	1361	945	
H546 Using #10"-16" Screws	33mils (20ga)	33	561	307	1121	507	1682	637
	43mils (18ga)	33	832	455	1664	753	2496	945
	54mils (16ga)	33	1172	641	2345	1061	2634	1332
		50	1682	919	2634	1522	2634	1910
	68mils (14ga)	33	1655	905	2634	1498	2634	1880
		50	1682	919	2634	1522	2634	1910
97mils (12ga)	33	1682	919	2634	1522	2634	1910	
	50	1682	919	2634	1522	2634	1910	
H686 Using 1/4"-14" Screws	33mils (20ga)	33	630	344	1260	570	1890	716
	43mils (18ga)	33	935	511	1870	846	2805	1062
	54mils (16ga)	33	1318	720	2635	1193	3821	1497
		50	1997	1091	3821	1807	3821	2268
	68mils (14ga)	33	1860	1017	3720	1684	3821	2113
		50	2818	1541	3821	2551	3821	3201
97mils (12ga)	33	2818	1541	3821	2551	3821	3201	
	50	2818	1541	3821	2551	3821	3201	

Notes:

- To determine the connection capacity, use the minimum value from the jamb and header columns. For instance, using an H686 for the 30-screw option with a 16 gauge, 50ksi jamb stud and a 12 gauge, 50ksi header, the allowable load per plate is 3201 lbs (i.e., the minimum of 3821 lbs for the jamb and 3201 lbs for the header).
- For the H436 and the H546, the tabulated capacity is based on #10-16 screws with an ultimate screw shear capacity of 1400 lbs per screw. For the H686, the tabulated capacity is based on 1/4"-14 screws with an ultimate screw shear capacity of 2600 lbs per screw.
- H436 connectors are 33ksi, H546 and H686 connectors are 50ksi.
- Reference figures above for screw placement of the 10-, 20- and 30-screw options.
- Values are based on a minimum of (2) back-to-back jamb studs as shown above.

Typical Construction Details

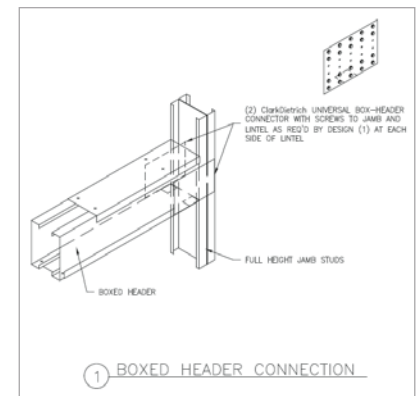

Visit our CAD Library at [clarkdietrich.com](http://clarkdietrich.com) to view or download construction details in .dwg, .dxf, and .pdf formats.

## ClarkDietrich Holdown

### Secure and hold down shearwalls to the structure foundation.

ClarkDietrich holdowns provide cost-effective shearwall attachment and are used to transfer tension loads between floors or from structural members to the foundation. Two-piece welded construction comes in three sizes for optimal performance. Installation is made easy with prepunched holes.

#### ALTERNATIVE PRODUCTS

EasyClip™ T-Series™ Tall Anchor Clip  
Moment Clip

#### PRODUCT DIMENSIONS

**CD8-S, CD8-B:** 2-5/8" x 11"

**CD10-S, CD10-B:** 2-5/8" x 13-1/2"

**CD15-S, CD15-B:** 2-5/8" x 19"

#### MATERIAL SPECIFICATIONS

**Gauge:** 7 gauge (171.3mils) with 1/2" bearing plate

**Steel Thickness:** 0.1713 inches

#### Anchor Hole Size:

CD8-S, CD8-B, CD10-S, CD10-B: 7/8" x 1-1/8"

CD15-S, CD15-B: 1" x 1-1/8"

**ASTM:** A36, A1011

**Coating:** Envirocron® Powder Coating

#### INSTALLATION

Install the holdowns using anchor bolts or alternate anchorage calculated to resist the tension load for your specific application. Use steel nylon locking nuts or thread adhesive to minimize the chance of nut spin. Anchor bolt washer is not required.

For the screwed holdowns, secure the CD holdown to the steel framing member by filling all the prepunched holes with #14 self-tapping screws to achieve listed capacities.

For the bolted holdowns, secure the CD holdown to the steel framing member with 3/4" and 1/2" diameter bolts in the prepunched holes per the design load table to achieve listed capacities. Field drill holes in the framing member as required to accommodate the required bolts.



Screwed Holddown

Bolted Holddown

Boundary members (back-to-back studs) shall be designed by a qualified professional. To tie back-to-back stud members together, the Designer must determine the fasteners required to bind members to act as one unit. CD holdowns can be welded per Designer's recommendation and specification. Welding procedures shall be qualified as specified in AWS D1.3.

Welded connections used for cold-formed steel structural members in which the thickness of the thinnest connected part is 0.18 inch or less shall comply to AISI S100-2012 specification Section E2.

Reference section R603.9.4.2 of the International Residential Code (IRC) for holdown requirements in residential applications. Consult the engineer of record for commercial applications.



## ClarkDietrich Holdowns

Product code	Thickness		Size (in)	Packaging
	Mils (Gauge)	Design thickness (in)		
CD8-S	171.3mils (7ga)	0.188	2-5/8 x 11	Dependent on Order Quantity
CD10-S	171.3mils (7ga)	0.188	2-5/8 x 13-1/2	
CD15-S	171.3mils (7ga)	0.188	2-5/8 x 19	

Product code	Thickness		Size (in)	Packaging
	Mils (Gauge)	Design thickness (in)		
CD8-B	171.3mils (7ga)	0.188	2-5/8 x 11	Dependent on Order Quantity
CD10-B	171.3mils (7ga)	0.188	2-5/8 x 13-1/2	
CD15-B	171.3mils (7ga)	0.188	2-5/8 x 19	

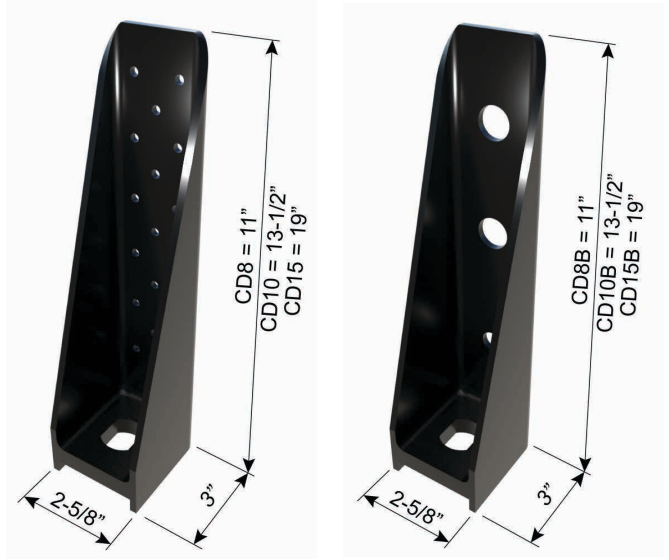

### SOURCES OF DEFLECTION AT THE SHEARWALL HOLDOWN CONNECTIONS:

- A** Eccentricity in stud—when a holdown is installed on only one side of the stud, an eccentricity exists during loading that can cause additional movement in the shearwall system.
- B** Nut spin—unrestrained anchor bolt nuts can spin loose during cyclic loading; the use of steel nylon locking nuts or thread adhesive may prevent nut spin.
- C** Lack of nut tightening—additional movement can occur when nuts are not tightened sufficiently.
- D** Deflection of the holdown—deflection can occur in the holdown under load caused by stresses due to earthquake or high wind.
- E** Vertical deflection at the holdown seat caused by stud rotation—lateral displacement at the top of the wall rotates the stud around its base causing the holdown base plate to displace vertically.

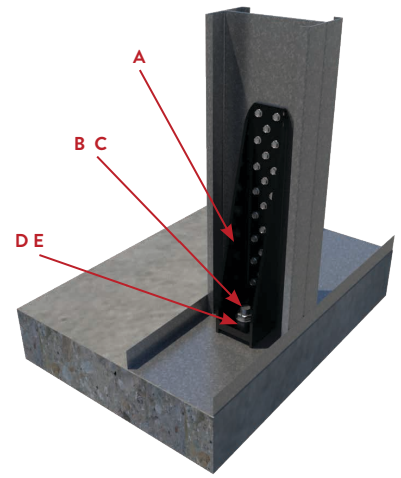

### TYPICAL CONSTRUCTION DETAILS

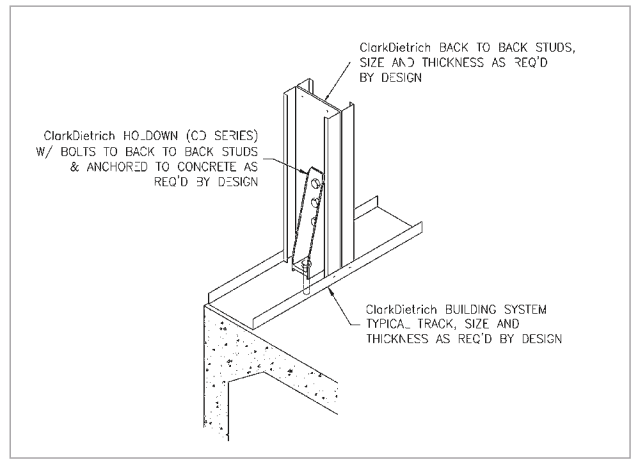
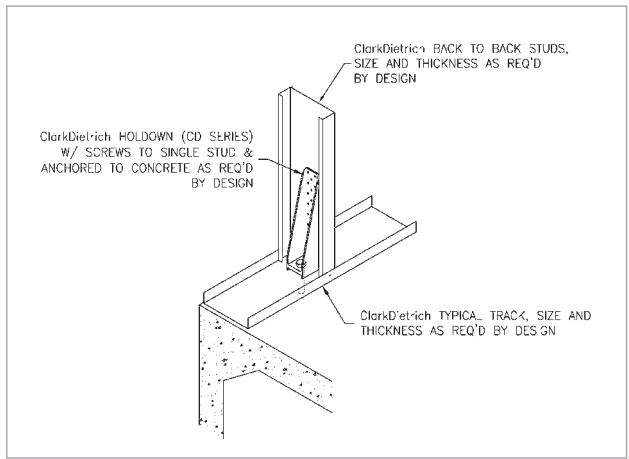

Visit our CAD Library at [clarkdietrich.com](http://clarkdietrich.com) to view or download construction details in .dwg, .dxf, and .pdf formats.

## ClarkDietrich Holdown

## ClarkDietrich CD8-S, CD10-S, CD15-S Holdowns

## SINGLE FRAMING MEMBER WITH SCREWS

Product code	Height	Fasteners		Stud member thickness	ASD		LRFD		Nominal tension load (lbs)
		Anchor diameter	Stud fasteners		Tension load (lbs)	Deflection at ASD load (in)	Tension load (lbs)	Deflection at LRFD load (in)	
CD8-S	11"	7/8"	(17) #14 Screws	1-33mils (1-20ga)	1905	0.081	2860	0.107	5720
				1-43mils (1-18ga)	2485	0.057	3730	0.079	7455
				1-54mils (1-16ga)	4505	0.064	6755	0.086	13510
				1-68mils (1-14ga)	5675	0.058	8510	0.079	17020
				1-97mils (1-12ga)	8095	0.051	12140	0.072	24280
CD10-S	13-1/2"	7/8"	(23) #14 Screws	1-33mils (1-20ga)	2325	0.049	3490	0.066	6975
				1-43mils (1-18ga)	3030	0.034	4550	0.052	9095
				1-54mils (1-16ga)	5495	0.038	8245	0.055	16485
				1-68mils (1-14ga)	6920	0.041	10385	0.059	20765
				1-97mils (1-12ga)	9875	0.044	14810	0.062	29620
CD15-S	19"	1"	(32) #14 Screws	1-33mils (1-20ga)	2675	0.025	4015	0.040	8025
				1-43mils (1-18ga)	3485	0.026	5230	0.037	10460
				1-54mils (1-16ga)	6320	0.016	9480	0.030	18955
				1-68mils (1-14ga)	7960	0.025	11940	0.036	23880
				1-97mils (1-12ga)	11355	0.036	17035	0.050	34065

**Notes:**

- The designer is responsible for design checks for the substrate the Holdown is attached to and the anchorage to the substrate. The capacities listed in the table may exceed those of the substrate and/or the anchorage to the substrate.
- Tabulated loads may exceed ASTM A36 or A307 anchor bolt tension capacities.
- Stud/framing member design by qualified professional. Tabulated loads are based on minimum 1-5/8" wide flanged stud/framing member.
- 1/4" self-drilling screws can be substituted for #14 self-drilling screws.
- Deflection at ASD and LRFD loads includes fastener slip, holdown elongation and anchor bolt elongation.
- Nominal tension load is based on the average ultimate (peak) load from tests. AISI Lateral Design standard requires holdown to have nominal strength to resist lesser of amplified seismic load or what the system can deliver.
- For ASD and LRFD loads, safety factor of 3.0 and resistance factor of 0.50 was applied.

## ClarkDietrich CD8-B, CD10-B, CD15-B Holdowns

## SINGLE FRAMING MEMBER WITH BOLTS

Product code	Height	Fasteners		Stud member thickness	ASD		LRFD		Nominal tension load (lbs)
		Anchor diameter	Stud fasteners		Tension load (lbs)	Deflection at ASD load (in)	Tension load (lbs)	Deflection at LRFD load (in)	
CD8-B	11"	7/8"	(2) 3/4" Dia. Bolts + (1) 1/2" Dia. Bolt	1-33mils (1-20ga)	2015	0.079	2910	0.103	4475
				1-43mils (1-18ga)	2630	0.163	3795	0.211	5835
				1-54mils (1-16ga)	4765	0.141	6875	0.177	10575
				1-68mils (1-14ga)	6000	0.271	8660	0.315	13325
				1-97mils (1-12ga)	8560	0.275	12355	0.317	19005
CD10-B	13-1/2"	7/8"	(3) 3/4" Dia. Bolts + (1) 1/2" Dia. Bolt	1-33mils (1-20ga)	2460	0.142	3550	0.182	5460
				1-43mils (1-18ga)	3205	0.055	4630	0.103	7120
				1-54mils (1-16ga)	5815	0.126	8390	0.171	12905
				1-68mils (1-14ga)	7320	0.148	10565	0.192	16255
				1-97mils (1-12ga)	10445	0.190	15070	0.249	23185
CD15-B	19"	1"	(4) 3/4" Dia. Bolts + (1) 1/2" Dia. Bolt	1-33mils (1-20ga)	2705	0.127	3905	0.153	6005
				1-43mils (1-18ga)	3525	0.074	5090	0.105	7830
				1-54mils (1-16ga)	6395	0.121	9225	0.154	14195
				1-68mils (1-14ga)	8055	0.170	11620	0.198	17880
				1-97mils (1-12ga)	11490	0.196	16580	0.235	25505

**Notes:**

- The designer is responsible for design checks for the substrate the Holdown is attached to and the anchorage to the substrate. The capacities listed in the table may exceed those of the substrate and/or the anchorage to the substrate.
- Tabulated loads may exceed ASTM A36 or A307 anchor bolt tension capacities.
- Stud/framing member design by qualified professional. Tabulated loads are based on minimum 1-5/8" wide flanged stud/framing member.
- At a minimum, bolts to framing/stud connection shall comply with ASTM A307. Both 3/4-inch diameter and 1/2" diameter bolt shall be used (as listed in the design table) to achieve tabulated capacities.
- Deflection at ASD and LRFD loads includes fastener slip, holdown elongation and anchor bolt elongation.
- Nominal tension load is based on the average ultimate (peak) load from tests. AISI Lateral Design standard requires holdown to have nominal strength to resist lesser of amplified seismic load or what the system can deliver.
- For ASD and LRFD loads, safety factor of 2.22 and resistance factor of 0.65 was applied.

## ClarkDietrich CD8-S, CD10-S, CD15-S Holdowns

## BACK-TO-BACK FRAMING MEMBER WITH SCREWS

Product code	Height	Fasteners		Stud member thickness	ASD		LRFD		Nominal tension load (lbs)
		Anchor diameter	Stud fasteners		Tension load (lbs)	Deflection at ASD load (in)	Tension load (lbs)	Deflection at LRFD load (in)	
CD8-S	11"	7/8"	(17) #14 Screws	2-33mils (2-20ga)	6962	0.08	11139	0.119	20885
				2-43mils (2-18ga)	8164	0.07	13062	0.124	24492
				2-54mils (2-16ga)	11253	0.083	18005	0.126	33759
				2-68mils (2-14ga)	12240	0.095	19585	0.135	36721
				2-97mils (2-12ga)	12240	0.095	19585	0.135	36721
CD10-S	13-1/2"	7/8"	(23) #14 Screws	2-33mils (2-20ga)	7293	0.12	11669	0.16	21880
				2-43mils (2-18ga)	9314	0.068	14902	0.106	27941
				2-54mils (2-16ga)	12502	0.083	20004	0.125	37507
				2-68mils (2-14ga)	12899	0.083	20638	0.127	38697
				2-97mils (2-12ga)	12899	0.083	20638	0.127	38697
CD15-S	19"	1"	(32) #14 Screws	2-33mils (2-20ga)	7610	0.098	12177	0.125	22831
				2-43mils (2-18ga)	9235	0.067	14776	0.104	27705
				2-54mils (2-16ga)	13532	0.088	21650	0.128	40595
				2-68mils (2-14ga)	13695	0.063	21911	0.096	41084
				2-97mils (2-12ga)	13695	0.063	21911	0.096	41084

**Notes:**

- The designer is responsible for design checks for the substrate the Holdown is attached to and the anchorage to the substrate. The capacities listed in the table may exceed those of the substrate and/or the anchorage to the substrate.
- Tabulated loads may exceed ASTM A36 or A307 anchor bolt tension capacities.
- Stud/framing member design by qualified professional. Tabulated loads are based on minimum 1-5/8" wide flanged stud/framing member.
- 1/4" self-drilling screws can be substituted for #14 self-drilling screws.
- Deflection at ASD and LRFD loads includes fastener slip, holdown elongation and anchor bolt elongation.
- Nominal tension load is based on the average ultimate (peak) load from tests. AISI Lateral Design standard requires holdown to have nominal strength to resist lesser of amplified seismic load or what the system can deliver.
- For ASD and LRFD loads, safety factor of 3.0 and resistance factor of 0.50 was applied.

## ClarkDietrich CD8-B, CD10-B, CD15-B Holdowns

## BACK-TO-BACK FRAMING MEMBER WITH BOLTS

Product code	Height	Fasteners		Stud member thickness	ASD		LRFD		Nominal tension load (lbs)
		Anchor diameter	Stud fasteners		Tension load (lbs)	Deflection at ASD load (in)	Tension load (lbs)	Deflection at LRFD load (in)	
CD8-B	11"	7/8"	(2) 3/4" Dia. Bolts + (1) 1/2" Dia. Bolt	2-33mils (2-20ga)	4030	0.206	5820	0.243	8950
				2-43mils (2-18ga)	5255	0.149	7585	0.192	11670
				2-54mils (2-16ga)	9530	0.182	13750	0.240	21155
				2-68mils (2-14ga)	12005	0.268	17325	0.333	26650
				2-97mils (2-12ga)	13650	0.286	19700	0.368	30305
CD10-B	13-1/2"	7/8"	(3) 3/4" Dia. Bolts + (1) 1/2" Dia. Bolt	2-33mils (2-20ga)	4920	0.222	7100	0.274	10920
				2-43mils (2-18ga)	6410	0.264	9255	0.314	14235
				2-54mils (2-16ga)	11625	0.260	16775	0.313	25810
				2-68mils (2-14ga)	14645	0.201	21130	0.258	32510
				2-97mils (2-12ga)	15045	0.205	21715	0.263	33405
CD15-B	19"	1"	(4) 3/4" Dia. Bolts + (1) 1/2" Dia. Bolt	2-33mils (2-20ga)	5410	0.166	7810	0.193	12015
				2-43mils (2-18ga)	7055	0.202	10180	0.235	15660
				2-54mils (2-16ga)	12790	0.175	18455	0.228	28390
				2-68mils (2-14ga)	16110	0.208	23245	0.270	35760
				2-97mils (2-12ga)	17685	0.222	25520	0.290	39265

**Notes:**

- The designer is responsible for design checks for the substrate the Holdown is attached to and the anchorage to the substrate. The capacities listed in the table may exceed those of the substrate and/or the anchorage to the substrate.
- Tabulated loads may exceed ASTM A36 or A307 anchor bolt tension capacities.
- Stud/framing member design by qualified professional. Tabulated loads are based on minimum 1-5/8" wide flanged stud/framing member and the minimum stud thickness for fastener connection.
- At a minimum, bolts to framing/stud connection shall comply with ASTM A307. Both 3/4-inch diameter and 1/2" diameter bolt shall be used (as listed in the design table) to achieve tabulated capacities.
- Deflection at ASD and LRFD loads includes fastener slip, holdown elongation and anchor bolt elongation.
- Nominal tension load is based on the average ultimate (peak) load from tests. AISI Lateral Design standard requires holdown to have nominal strength to resist lesser of amplified seismic load or what the system can deliver.
- For ASD and LRFD loads, safety factor of 2.22 and resistance factor of 0.65 was applied.

## Holdown Plate

Secure and hold down structural steel endposts between floors or to the foundation embed plate (by others).

ClarkDietrich HDP holdown plates are designed for taller construction and higher tension loads; transferring the tension loads between floors or from structural members to the foundation embed plate (by others). The HDP holdown plates are pre-punched and available in six sizes that can be bolted or welded. They can be used for panelized construction or stick-built construction.

### ALTERNATIVE PRODUCTS

ClarkDietrich Holdown

### PRODUCT DIMENSIONS

**300HDP025:** 1/4" x 3" X 24"

**300HDP038:** 3/8" x 3" X 24"

**300HDP050:** 1/2" x 3" X 30"

**500HDP025:** 1/4" x 5" X 24"

**500HDP038:** 3/8" x 5" X 24"

**500HDP050:** 1/2" x 5" X 30"

### MATERIAL SPECIFICATIONS

**Steel Thickness:** 1/4", 3/8" and 1/2" Plate

**Bolt Hole Size:** 13/16"

**ASTM:** 1/4" and 3/8" A36 Plate  
1/2" A572 Gr50 Plate

**Coating:** Envirocron® Powder Coating

### INSTALLATION

Field trimming, welding or drilling will be required when installing holdown plates. When trimming cold-formed steel, use a grinder or plasma cutter. No torch cutting.

Clean all trimmed, cut, drilled and welded areas and paint with a zinc-rich (cold galvanize) paint.

Endpost must align from level to level and holdown plates set flat on the post components before welding or bolting.

Holdown plates are intended for tension loads and not tested for compression loads. Endposts with bearing gaps must have a structural shim installed for full compression load path.

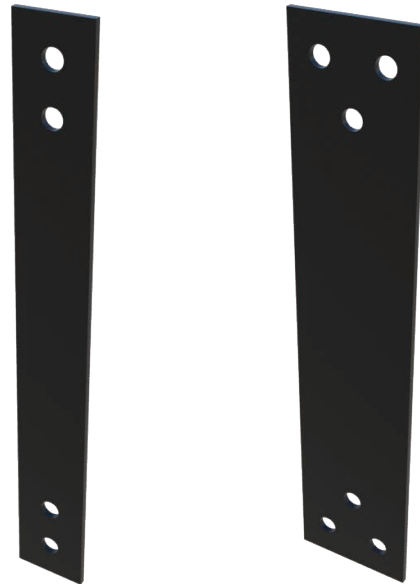

CD holdown plates can be welded or bolted, but a designer of record shall check the endpost connection capacity and provide a specific connection detail for each project.

Welding to cold-formed steel endpost members shall be with 97 mils (50Ksi) minimum with a maximum weld size of 1/8" fillet. Welder shall be certified for sheet steel welding.

### ClarkDietrich Holddown Plate (HDP) - 3" Wide

Product code	Thickness	Width	Length	Holes per End	Packaging
300HDP025	1/4"	3"	24"	2	250
300HDP038	3/8"	3"	24"	3	200
300HDP050	1/2"	3"	30"	4	100

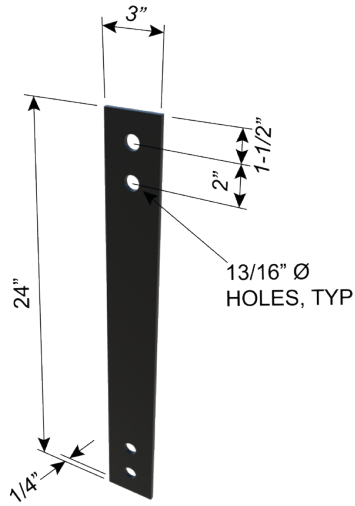

300HDP025

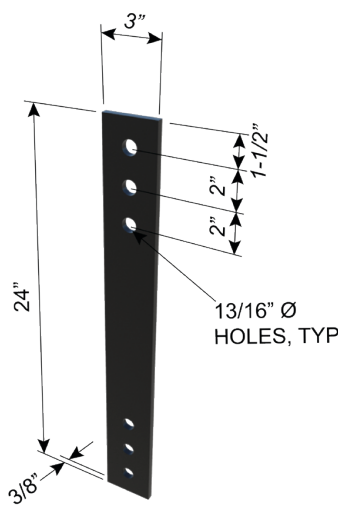

300HDP038

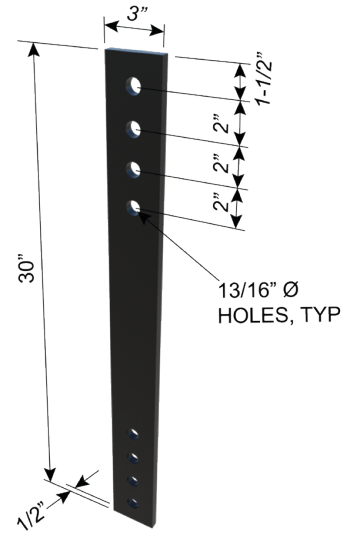

300HDP050

### ClarkDietrich Holddown Plate (HDP) - 5" Wide

Product code	Thickness	Width	Length	Holes per End	Packaging
500HDP025	1/4"	5"	24"	3	150
500HDP038	3/8"	5"	24"	4	100
500HDP050	1/2"	5"	30"	6	50

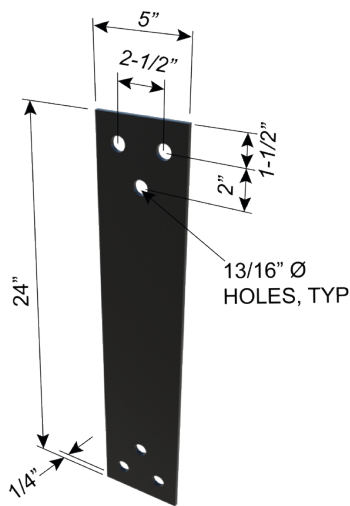

500HDP025

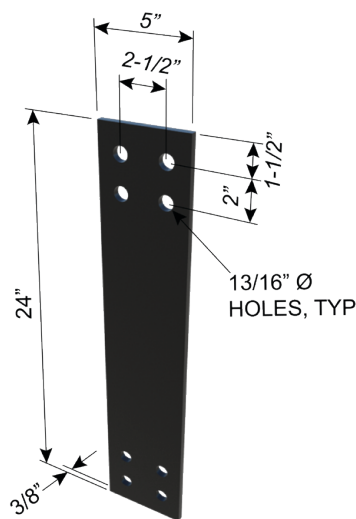

500HDP038

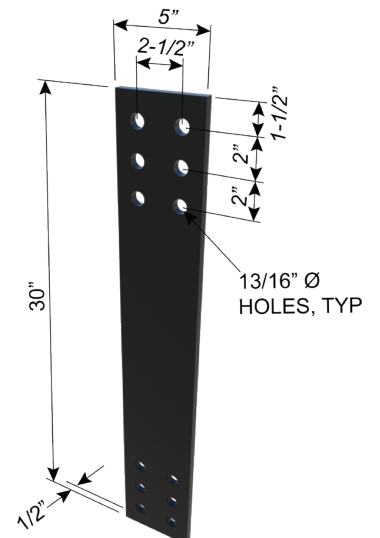

500HDP050

## Holdown Plate

## Holdown Plate (HDP): Bolted

Product code	Plate Dimensions and Properties					Fastener at Each End	HDP Tension Capacities		
	Thickness (in)	Width (in)	Length (in)	Yield Strength (ksi)	Tensile Strength (ksi)		Nominal Strength, kips	ASD load, kips	LRFD load, kips
300HDP025	0.250	3	24	36	58	(2) 3/4" Bolts	27.00	15.86	23.79
300HDP038	0.375	3	24	36	58	(3) 3/4" Bolts	40.50	23.79	35.68
300HDP050	0.500	3	30	50	65	(4) 3/4" Bolts	71.09	35.55	53.32
500HDP025	0.250	5	24	36	58	(3) 3/4" Bolts	45.00	24.47	36.70
500HDP038	0.375	5	24	36	58	(4) 3/4" Bolts	67.50	36.70	55.05
500HDP050	0.500	5	30	50	65	(6) 3/4" Bolts	109.69	54.84	82.27

**Notes:**

- Listed capacities are based on AISI S100-16 (2020) w/S2-20 and ANSI/AISC 360-16.
- Limitations of hole spacing and edge distance are per ANSI/AISC 360-16 Section J3.
- HDP025 and HDP038 plates use A36 steel, HDP050 plate use A572-Gr50 steel.
- For fasteners, use 3/4" x 2-1/2" A325T (full thread) bolts with F436 washers and A563 heavy hex nut.
- Nominal strengths are controlled by HDP plate tensile yielding.
- ASD and LRFD loads are controlled by HDP plate tensile rupture.
- Capacities listed for HDP plate and bolt only, substrate connection capacities should be checked separately.

## TYPICAL CONSTRUCTION DETAILS

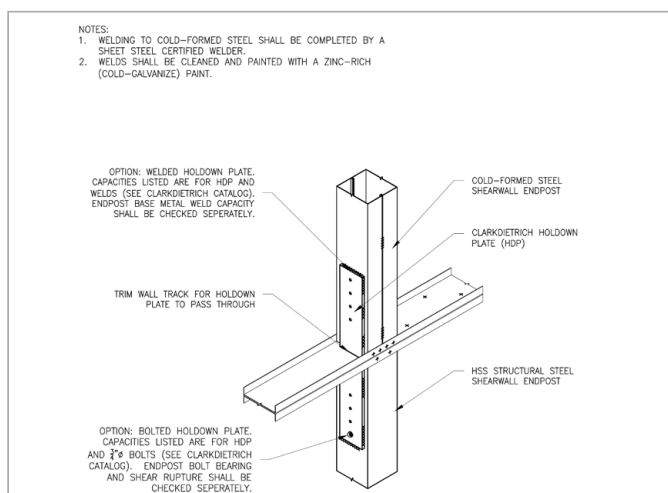
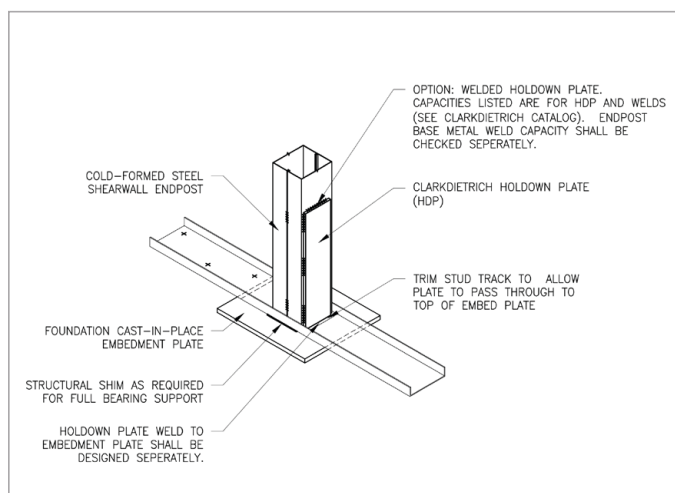

Visit our CAD Library at [clarkdietrich.com](http://clarkdietrich.com) to view or download construction details in .dwg, .dxf, and .pdf formats.

## Holddown Plate (HDP): Welded

Product code	Plate Dimensions and Properties					Size of Weld (thickness), w (in)	HDP Weld Tension Capacities		
	Thickness (in)	Width (in)	Length (in)	Yield Strength $F_y$ (ksi)	Tensile Strength $F_u$ (ksi)		Nominal Strength, kips	ASD load, kips	LRFD load, kips
300HDP025	0.250	3	24	36	58	1/8"	27.00	16.17	24.30
300HDP038	0.375	3	24	36	58	3/16"	40.50	24.25	36.45
300HDP050	0.500	3	30	50	65	5/16"	75.00	44.91	67.50
500HDP025	0.250	5	24	36	58	1/8"	45.00	26.95	40.50
500HDP038	0.375	5	24	36	58	3/16"	67.50	40.42	60.75
500HDP050	0.500	5	30	50	65	5/16"	125.00	74.85	112.50

Product code	Longitudinal Weld Length/Side		
	Nominal Strength (in)	ASD load (in)	LRFD load (in)
300HDP025	5	6	6
300HDP038	5	6	6
300HDP050	5	5	5
500HDP025	8	9	9
500HDP038	8	9	9
500HDP050	7	9	9

### Notes:

- Listed capacities and weld lengths are based on AISI S100-16 (2020) w/S2-20 and ANSI/AISC 360-16.
- Listed capacities applicable for Fillet Welds only.
- Listed capacities are based on E60xx or E70xx electrodes for A36 steel plates, E70XX electrodes for A572-Gr50 steel plates.
- Limitations of weld size (thickness of weld) are per ANSI/AISC 360-16 Section J2.
- HDP025 and HDP038 plates use A36 steel, HDP050 plate use A572-Gr50 steel.
- Weld capacities are controlled by HDP plate tensile yielding.
- Capacities listed for HDP plate only, substrate connection capacities should be checked separately.

## ClarkDietrich Moment Clip

Moment connection for knee walls and shear walls to the structure foundation.

ClarkDietrich moment clips are high-performance, cost effective solutions for knee wall-to-foundation connections and shear wall-to-foundation connections. These multi-application clips feature a 1/4" thick A36 steel stiffening plate that provides superior design values for maximum performance. The moment clips are designed to resist horizontal, torsional and vertical (uplift) loads. These clips are prepunched with a series of attachment holes for steel framing connections and a 1/2" anchor bolt hole for foundation connections.

### PRODUCT DIMENSIONS

2" x 4" x 3-1/2"

2" x 4" x 5-1/2"

2" x 4" x 7-1/2"

1/4" A36 steel stiffening plate

1-3/4" x 3-3/8"

1-3/4" x 5-3/8"

1-3/4" x 7-3/8"

### MATERIAL SPECIFICATIONS

**Gauge:** 14 gauge (68mils)

**Design Thickness:** 0.0713 inches

**Gauge:** 12 gauge (97mils)

**Design Thickness:** 0.1017 inches

**Gauge:** 10 gauge (118mils)

**Design Thickness:** 0.1242 inches

**Coating:** G90

**Yield Strength:** 50ksi

**ASTM:** A36, A653, A1003

### INSTALLATION

Secure the Moment Clip to the steel framing member by using #12 screws in the prepunched holes. Number of screws and screw pattern is based on load required to achieve listed capacities.

Place 1/4" steel stiffening plate on top of short leg of Moment Clip so anchor holes are aligned.

Secure 1/4" steel stiffening plate and Moment Clip to foundation using 1/2" x 2" long Hilti Kwik-Bolt 3 or alternate anchorage calculated to resist the tension load for your specific application.

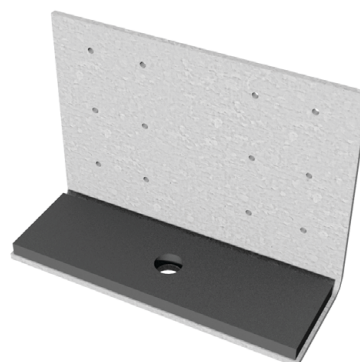
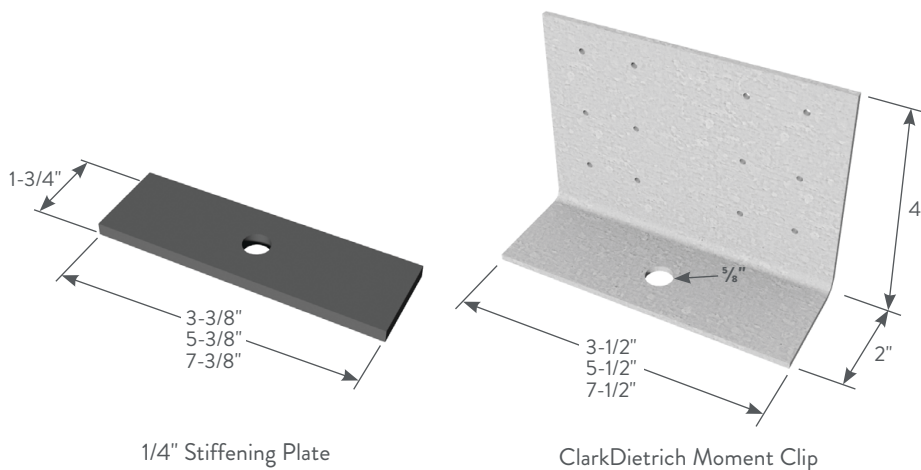

ClarkDietrich Moment Clip w/ Stiffening Plate

### ClarkDietrich Moment Clips (MC Series)

Product code	Thickness		Size (in)	Packaging Pcs./Bucket
	Mils (Gauge)	Design thickness (in)		
MC683P	68mils (14ga)	0.0713	2" x 4" x 3-1/2"	25
MC685P	68mils (14ga)	0.0713	2" x 4" x 5-1/2"	25
MC687P	68mils (14ga)	0.0713	2" x 4" x 7-1/2"	25
MC973P	97mils (12ga)	0.1017	2" x 4" x 3-1/2"	25
MC975P	97mils (12ga)	0.1017	2" x 4" x 5-1/2"	25
MC977P	97mils (12ga)	0.1017	2" x 4" x 7-1/2"	25
MC103P	68mils (14ga)	0.1242	2" x 4" x 3-1/2"	25
MC105P	97mils (12ga)	0.1242	2" x 4" x 5-1/2"	25
MC107P	118mils (10ga)	0.1242	2" x 4" x 7-1/2"	25



### ClarkDietrich Moment Clips Allowable Loads

Product code	Stud member thickness Mils (Gauge)	Stud Fy (ksi)	F1 (Shear), (lbs)			F2 (Tension), (lbs)			M (Moment), (in-lbs)			Rotational stiffness for wind deflection (in-lbs/radian)
			Number of #12 screws to stud						1/2" dia. anchor to structure			
			4	6	12	4	6	12	4	6	12	
<b>MC683P</b> 2" x 4" x 3-1/2" 68mils (14ga)	33mils (20ga)	33	372	508	840	754	1131	2261 <sup>2</sup>	1401	1784	2462 <sup>3</sup>	133,000
	43mils (18ga)	33	554	756	1250	1122	1683 <sup>2</sup>	2736 <sup>2</sup>	2084 <sup>3</sup>	2581 <sup>3</sup>	2581 <sup>3</sup>	
	54mils (16ga)	50	1126	1536	2086 <sup>1</sup>	2278 <sup>2</sup>	2736 <sup>2</sup>	2736 <sup>2</sup>	2743 <sup>3</sup>	2743 <sup>3</sup>	2743 <sup>3</sup>	
	68mils (14ga)	50	1535	2086 <sup>1</sup>	2086 <sup>1</sup>	2736 <sup>2</sup>	2736 <sup>2</sup>	2736 <sup>2</sup>	2756 <sup>3</sup>	2756 <sup>3</sup>	2756 <sup>3</sup>	
	97mils (12ga)	50	1535	2086 <sup>1</sup>	2086 <sup>1</sup>	2736 <sup>2</sup>	2736 <sup>2</sup>	2736 <sup>2</sup>	2756 <sup>3</sup>	2756 <sup>3</sup>	2756 <sup>3</sup>	
<b>MC973P</b> 2" x 4" x 3-1/2" 97mils (12ga)	33mils (20ga)	33	372	508	840	754	1131	2261 <sup>2</sup>	1401	1784 <sup>3</sup>	2560 <sup>3</sup>	140,100
	43mils (18ga)	33	554	756	1250	1122	1683 <sup>2</sup>	3365 <sup>2</sup>	2084 <sup>3</sup>	2655	2862 <sup>3</sup>	
	54mils (16ga)	50	1126	1536	2538 <sup>1</sup>	2278 <sup>2</sup>	3417 <sup>2</sup>	4065 <sup>2</sup>	2862 <sup>3</sup>	2862 <sup>3</sup>	2862 <sup>3</sup>	
	68mils (14ga)	50	1535	2094 <sup>1</sup>	2975 <sup>1</sup>	3107 <sup>2</sup>	4181 <sup>2</sup>	4181 <sup>2</sup>	2862 <sup>3</sup>	2862 <sup>3</sup>	2862 <sup>3</sup>	
	97mils (12ga)	50	1535	2094 <sup>1</sup>	2975 <sup>1</sup>	3107 <sup>2</sup>	4181 <sup>2</sup>	4181 <sup>2</sup>	2862 <sup>3</sup>	2862 <sup>3</sup>	2862 <sup>3</sup>	
<b>MC103P</b> 2" x 4" x 3-1/2" 118mils (10ga)	33mils (20ga)	33	372	508	840	754	1131	2261 <sup>2</sup>	1401	1784 <sup>3</sup>	2609 <sup>3</sup>	143,900
	43mils (18ga)	33	554	756	1250	1122	1683 <sup>2</sup>	3365 <sup>2</sup>	2084 <sup>3</sup>	2655	2945 <sup>3</sup>	
	54mils (16ga)	50	1126	1536	2538 <sup>1</sup>	2278 <sup>2</sup>	3417 <sup>2</sup>	3828 <sup>2</sup>	2945 <sup>3</sup>	2945 <sup>3</sup>	2945 <sup>3</sup>	
	68mils (14ga)	50	1535	2094 <sup>1</sup>	3462 <sup>1</sup>	3107 <sup>2</sup>	3828 <sup>2</sup>	3828 <sup>2</sup>	2945 <sup>3</sup>	2945 <sup>3</sup>	2945 <sup>3</sup>	
	97mils (12ga)	50	1535	2094 <sup>1</sup>	3462 <sup>1</sup>	3107 <sup>2</sup>	3828 <sup>2</sup>	3828 <sup>2</sup>	2945 <sup>3</sup>	2945 <sup>3</sup>	2945 <sup>3</sup>	
<b>MC685P</b> 2" x 4" x 5-1/2" 68mils (14ga)	33mils (20ga)	33	441	630	1029	754	1131	2261 <sup>2</sup>	1778	2417	3396 <sup>3</sup>	252,000
	43mils (18ga)	33	656	937	1531	1122	1683 <sup>2</sup>	2736 <sup>2</sup>	2646	3597 <sup>2</sup>	4993 <sup>3</sup>	
	54mils (16ga)	50	1333	1903 <sup>1</sup>	2086 <sup>1</sup>	2278 <sup>2</sup>	2736 <sup>2</sup>	2736 <sup>2</sup>	5307 <sup>3</sup>	5307 <sup>3</sup>	5307 <sup>3</sup>	
	68mils (14ga)	50	1818 <sup>1</sup>	2086 <sup>1</sup>	2086 <sup>1</sup>	2736 <sup>2</sup>	2736 <sup>2</sup>	2736 <sup>2</sup>	5363 <sup>3</sup>	5363 <sup>3</sup>	5363 <sup>3</sup>	
	97mils (12ga)	50	1818 <sup>1</sup>	2086 <sup>1</sup>	2086 <sup>1</sup>	2736 <sup>2</sup>	2736 <sup>2</sup>	2736 <sup>2</sup>	5363 <sup>3</sup>	5363 <sup>3</sup>	5363 <sup>3</sup>	
<b>MC975P</b> 2" x 4" x 5-1/2" 97mils (12ga)	33mils (20ga)	33	441	630	1029	754	1131	2261 <sup>2</sup>	1778	2417	3396 <sup>3</sup>	274,400
	43mils (18ga)	33	656	937	1531	1122	1683 <sup>2</sup>	3365 <sup>2</sup>	2646	3597 <sup>2</sup>	5025 <sup>3</sup>	
	54mils (16ga)	50	1333	1903 <sup>1</sup>	2975 <sup>1</sup>	2278 <sup>2</sup>	3417 <sup>2</sup>	4181 <sup>2</sup>	5373 <sup>3</sup>	5980 <sup>3</sup>	5980 <sup>3</sup>	
	68mils (14ga)	50	1818 <sup>1</sup>	2595 <sup>1</sup>	2975 <sup>1</sup>	3107 <sup>2</sup>	4181 <sup>2</sup>	4181 <sup>2</sup>	5980 <sup>3</sup>	5980 <sup>3</sup>	5980 <sup>3</sup>	
	97mils (12ga)	50	1818 <sup>1</sup>	2595 <sup>1</sup>	2975 <sup>1</sup>	3107 <sup>2</sup>	4181 <sup>2</sup>	4181 <sup>2</sup>	5980 <sup>3</sup>	5980 <sup>3</sup>	5980 <sup>3</sup>	
<b>MC105P</b> 2" x 4" x 5-1/2" 118mils (10ga)	33mils (20ga)	33	441	630	1029	754	1131	2261 <sup>2</sup>	1778	2417	3396 <sup>3</sup>	288,700
	43mils (18ga)	33	656	937	1531	1122	1683 <sup>2</sup>	3365 <sup>2</sup>	2646	3597 <sup>2</sup>	5053 <sup>3</sup>	
	54mils (16ga)	50	1333	1903 <sup>1</sup>	3109 <sup>1</sup>	2278 <sup>2</sup>	3417 <sup>2</sup>	4236 <sup>2</sup>	5373 <sup>3</sup>	6133 <sup>3</sup>	6133 <sup>3</sup>	
	68mils (14ga)	50	1818 <sup>1</sup>	2595 <sup>1</sup>	3633 <sup>1</sup>	3107 <sup>2</sup>	4236 <sup>2</sup>	4236 <sup>2</sup>	6133 <sup>3</sup>	6133 <sup>3</sup>	6133 <sup>3</sup>	
	97mils (12ga)	50	1818 <sup>1</sup>	2595 <sup>1</sup>	3633 <sup>1</sup>	3107 <sup>2</sup>	4236 <sup>2</sup>	4236 <sup>2</sup>	6133 <sup>3</sup>	6133 <sup>3</sup>	6133 <sup>3</sup>	
<b>MC687P</b> 2" x 4" x 7-1/2" 68mils (14ga)	43mils (18ga)	33	791	1164	1928 <sup>1</sup>	1122	1683 <sup>2</sup>	2736 <sup>2</sup>	3646	5199 <sup>2</sup>	6903 <sup>3</sup>	387,600
	54mils (16ga)	50	1606	2086 <sup>1</sup>	2086 <sup>1</sup>	2278 <sup>2</sup>	2736 <sup>2</sup>	2736 <sup>2</sup>	7403 <sup>3</sup>	7656 <sup>3</sup>	7656 <sup>3</sup>	
	68mils (14ga)	50	2086 <sup>1</sup>	2086 <sup>1</sup>	2086 <sup>1</sup>	2736 <sup>2</sup>	2736 <sup>2</sup>	2736 <sup>2</sup>	8186 <sup>3</sup>	8186 <sup>3</sup>	8186 <sup>3</sup>	
	97mils (12ga)	50	2086 <sup>1</sup>	2086 <sup>1</sup>	2086 <sup>1</sup>	2736 <sup>2</sup>	2736 <sup>2</sup>	2736 <sup>2</sup>	8186 <sup>3</sup>	8186 <sup>3</sup>	8186 <sup>3</sup>	
	43mils (18ga)	33	791	1164	1928 <sup>1</sup>	1122	1683 <sup>2</sup>	3365 <sup>2</sup>	3646	5199 <sup>2</sup>	6903 <sup>3</sup>	
<b>MC977P</b> 2" x 4" x 7-1/2" 97mils (12ga)	54mils (16ga)	50	1606	2363 <sup>1</sup>	2975 <sup>1</sup>	2278 <sup>2</sup>	3417 <sup>2</sup>	3875 <sup>2</sup>	7403 <sup>3</sup>	8979 <sup>3</sup>	8979 <sup>3</sup>	449,000
	68mils (14ga)	50	2190 <sup>1</sup>	2975 <sup>1</sup>	2975 <sup>1</sup>	3107 <sup>2</sup>	3875 <sup>2</sup>	3875 <sup>2</sup>	8979 <sup>3</sup>	8979 <sup>3</sup>	8979 <sup>3</sup>	
	97mils (12ga)	50	2190 <sup>1</sup>	2975 <sup>1</sup>	2975 <sup>1</sup>	3107 <sup>2</sup>	3875 <sup>2</sup>	3875 <sup>2</sup>	8979 <sup>3</sup>	8979 <sup>3</sup>	8979 <sup>3</sup>	
	43mils (18ga)	33	791	1164	1928 <sup>1</sup>	1122	1683 <sup>2</sup>	3365 <sup>2</sup>	3646	5199	6903 <sup>3</sup>	
	54mils (16ga)	50	1606	2363 <sup>1</sup>	3633 <sup>1</sup>	2278 <sup>2</sup>	3417 <sup>2</sup>	3835 <sup>2</sup>	7403 <sup>3</sup>	9180 <sup>3</sup>	9180 <sup>3</sup>	
<b>MC107P</b> 2" x 4" x 7-1/2" 118mils (10ga)	68mils (14ga)	50	2190 <sup>1</sup>	3223 <sup>1</sup>	3633 <sup>1</sup>	3107 <sup>2</sup>	4236 <sup>2</sup>	4236 <sup>2</sup>	9282 <sup>3</sup>	9282 <sup>3</sup>	9282 <sup>3</sup>	451,000
	97mils (12ga)	50	2190 <sup>1</sup>	3223 <sup>1</sup>	3633 <sup>1</sup>	3107 <sup>2</sup>	4236 <sup>2</sup>	4236 <sup>2</sup>	9282 <sup>3</sup>	9282 <sup>3</sup>	9282 <sup>3</sup>	

**Notes:**

- Cells marked with a "1" in shear column indicate that the shear capacity is limited to 1628 lbs when using 1/2" x 2" Hilti Kwik-Bolts into 3000psi concrete.
- Cells marked with a "2" in tension column indicate that the tension capacity is limited to 1509 lbs when using 1/2" x 2" Hilti Kwik-Bolts into 3000psi concrete.
- Cells marked with a "3" in the moment column indicate that the moment capacity is limited to 1761 in-lbs for 3-Series clips, 2767 in-lbs for 5-Series clips, and 3773 in-lbs for 7-Series clips when using 1/2" x 2" Hilti Kwik-Bolts into 3000psi concrete.
- Capacities listed in the table/notes assume that no load reductions are required for spacing or edge distance of Kwik-Bolts.
- Capacities listed in the table represent the capacity of the clip and the screws to the stud. Capacities listed in notes 1-3 are limits if the specified connector to the structure is used. Other 1/2" dia. anchors may be used to achieve the full clip capacity but must be designed separately.
- Moment capacities listed as Max. load/Factor of Safety. Loads must be limited by serviceability load taken as stiffness times the serviceability limit in radians.
- Stiffness is the max. allowable clip moment divided by the clip rotation measured at the max. allowable clip moment.
- No stud-to-track connection is required. Higher loads can be achieved when stud-to-track is connected.
- Use a linear interaction equation for connections involving any combination of F1, F2, and M.
- Allowable loads have not been increased for wind, seismic, or other factors.
- Torsional effects are considered on screw group for F1 & F2 (Shear & Tension) allowable loads.
- Hilti is a registered trademark of Hilti Aktiengesellschaft Corporation.
- It is the responsibility of the designer to properly detail connections on the contract drawings.



4 Screw Pattern

6 Screw Pattern

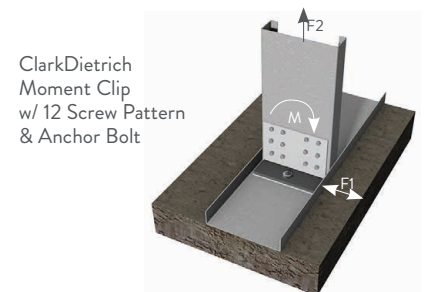

ClarkDietrich Moment Clip w/ 12 Screw Pattern & Anchor Bolt

## Pony Wall Heavy (12ga)

### Partial wall framing connection to the floor

The ClarkDietrich Pony Wall Heavy is intended to support out-of-plane loading of cantilevered partial wall systems that are unsupported at the top track. Out-of-plane loads are transferred to the floor system through the base-plate, which is welded to the Pony Wall Heavy stud member.

### INSTALLATION

Install the Pony Wall inside the track or directly to the floor structure. Anchor to the floor as designed by EOR. Attach the studs to both flanges of the Pony Wall. A minimum of 3-1/2" stud member can be used.

### PRODUCT DIMENSIONS

- PW24 = 23-3/4" tall with 3-3/8" wide x 8" long plate
- PW36 = 35-3/4" tall with 3-3/8" wide x 8" long plate
- PW48 = 47-3/4" tall with 3-3/8" wide x 8" long plate
- PW60 = 59-3/4" tall with 3-3/8" wide x 8" long plate

### MATERIAL SPECIFICATIONS

- Plate Material:** ASTM A36 1/2" thick hot rolled steel
- Stud Material:** ASTM A1011 SS Grade 50, 50ksi (340 MPa)  
12ga (97mils), 0.1017" Design thickness, 0.0966" Min. thickness
- Coating:** Envirocron® Powder Coating
- Packaging:** Individually
- ASTM:** A36, A1011



### Pony Wall Heavy (PW)

Product code	Thickness		Size (in)	Packaging
	Mils (Gauge)	Design thickness (in)		
PW24	97mils (12ga)	0.1242	23-3/4"	Individually
PW36			35-3/4"	Individually
PW48			47-3/4"	Individually
PW60			59-3/4"	Individually

### Pony Wall Heavy (PW) Rotational Stiffness

Product code	Member length, in	No. of Anchors	Rotational Stiffness for Wind Deflection (in-lbs/rad)*
PW	24/36/48/60	1	945,000
		4	1,128,775

\*Rotational stiffness is the max allowable moment divided by the Pony Wall Heavy (PW) rotation measured at the max allowable moment.

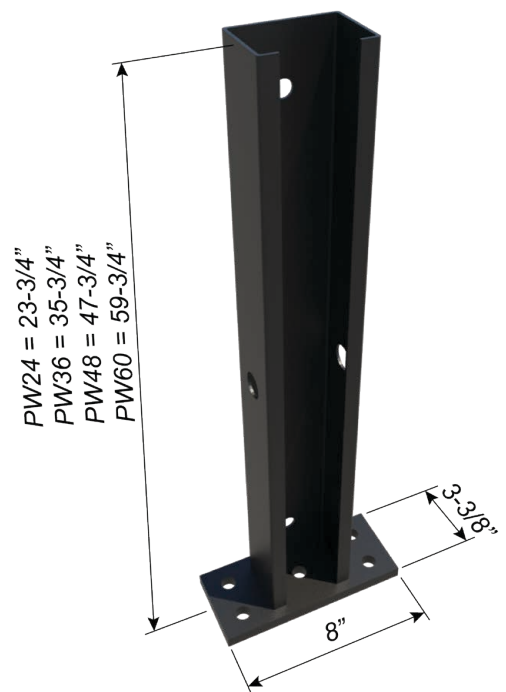
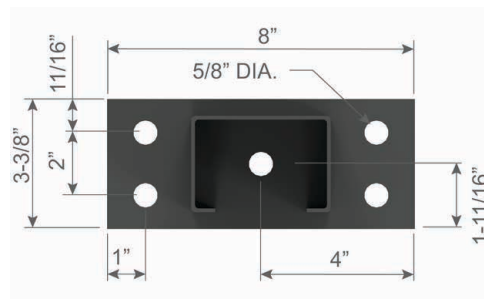

## Pony Wall Heavy (PW) Allowable Loads

### CONCENTRATED LOAD AT FREE END

#### MATERIAL SPECIFICATION:

##### **PONY WALL HEAVY STUD**

**Material Thickness:** 12ga (97mils), 0.1017" design thickness  
**Material Strength:** Structural grade 50, 50ksi minimum yield strength  
**ASTM:** A1011

##### **PONY WALL HEAVY BASE PLATE**

**Material Thickness:** 1/2" minimum thickness  
**Material Strength:** 36ksi minimum yield strength  
**ASTM:** A36



## Pony Wall Heavy (PW) Allowable Loads

### CONCENTRATED LOAD AT FREE END

Member designation	Pony Wall Length (in)	Max point load @ cantilever end, lbs					Moment (ASD) due to point load, in-lbs				
		L/720*	L/360*	L/240*	L/180*	Max	L/720*	L/360*	L/240*	L/180*	Max
Pony Wall Heavy	24	165	330	495	661	763	3,964	7,927	11,891	15,854	18,316
	36	73	147	220	294	509	2,642	5,285	7,927	10,569	18,316
	48	41	83	124	165	382	1,982	3,964	5,945	7,927	18,316
	60	26	53	79	106	305	1,585	3,171	4,756	6,342	18,316

\* The values shown are based on deflection of the strut member only which has an effective moment of inertia = 0.7739 in<sup>4</sup>. For overall assembly deflection, designers also need to consider deflection due to rotation at the base. The values needed for this additional analysis are provided in the rotational stiffness table.

#### Notes:

- ClarkDietrich Pony Wall Heavy is intended to support out-of-plane loading of cantilevered partial wall systems that are unsupported at the top track.
- Out-of-plane loads are transferred to the floor system through the base-plate, which is welded to Pony Wall Heavy member.
- ClarkDietrich Pony Wall Heavy (PW) may be used in place of standard framing members, or in conjunction with them to frame the wall.
- Listed allowable loads are based on Allowable Stress Design (ASD).
- Base connection between ClarkDietrich Pony Wall Heavy and support structure are designed by others.
- Serviceability/deflection needs to be checked separately. To do this, designers need to consider deflection of strut (effective moment of inertia = 0.7739 in<sup>4</sup>) and deflection due to rotation at the base (see rotational stiffness table).
- Listed maximum point load at cantilever end calculated using maximum allowable moment. When both point load and uniform loads are applied, combined loads should be limited to maximum allowable moment.
- It is the responsibility of the designer to properly detail connections on the contract drawings.

## Pony Wall Heavy (PW) Allowable Loads w/Anchors

### CONCENTRATED LOAD AT FREE END

Member designation	Pony Wall length, in	Anchors to structure	No. of Anchors	Max point load @ cantilever end, lbs					Allowable base moment, in-lbs				
				L/720*	L/360*	L/240*	L/180*	Max	L/720	L/360	L/240	L/180	Max
PW24	24	1/2" $\phi$ Hilti KB1 Expansion Anchor (3-5/8" Nominal Embedment, 3000psi Uncracked concrete)	1	142	142	142	142	142	3,403	3,403	3,403	3,403	3,403
			4	165	330	452	452	452	3,964	7,927	10,840	10,840	10,840
PW36	36		1	73	95	95	95	95	2,642	3,403	3,403	3,403	3,403
			4	73	147	220	294	301	2,642	5,285	7,927	10,569	10,840
PW48	48		1	41	71	71	71	71	1,982	3,403	3,403	3,403	3,403
			4	41	83	124	165	226	1,982	3,964	5,945	7,927	10,840
PW60	60		1	26	53	57	57	57	1,585	3,171	3,403	3,403	3,403
			4	26	53	79	106	181	1,585	3,171	4,756	6,342	10,840



(1) Anchor to structure



(4) Anchors to structure

\* The values shown are based on deflection of the strut member only which has an effective moment of inertia = 0.7739 in<sup>4</sup>. For overall assembly deflection, designers also need to consider deflection due to rotation at the base. The values needed for this additional analysis are provided in the rotational stiffness table.

#### Notes:

- ClarkDietrich Pony Wall Heavy is intended to support out-of-plane loading of cantilevered partial wall systems that are unsupported at the top track.
- Out-of-plane loads are transferred to the floor system through base-plate, which is welded to Pony Wall member.
- ClarkDietrich Pony Wall Heavy (PW) may be used in place of standard framing members, or in conjunction with them to frame the wall.
- Listed allowable loads are based on Allowable Stress Design (ASD).
- Serviceability/deflection needs to be checked separately. To do this, designers need to consider deflection of strut (effective moment of inertia = 0.7739 in<sup>4</sup>) and deflection due to rotation at the base (see rotational stiffness table).
- Above listed capacities w/anchors shall be used only when using 1/2"  $\phi$  Hilti KB1 Expansion Anchors to concrete.
- Other anchors may be used to achieve full Pony Wall Heavy capacity, but must be designed separately.
- Above listed capacities have not been increased for wind, seismic, or other factors.
- Hilti is a registered trademark of Hilti Aktiengesellschaft Corporation.
- It is the designer's responsibility to check for minimum concrete edge distance and minimum concrete thickness when using anchors.
- It is the responsibility of the designer to properly detail connections on the contract drawings.

## Pony Wall Heavy (12ga)

### Pony Wall Heavy (PW) Allowable Loads

### MAXIMUM ALLOWABLE LOADS

#### MATERIAL SPECIFICATION:

##### PONY WALL HEAVY STUD

**Material Thickness:** 12ga (97mils), 0.1017" design thickness  
**Material Strength:** Structural grade 50, 50ksi minimum yield strength  
**ASTM:** A1011

##### PONY WALL HEAVY BASE PLATE

**Material Thickness:** 1/2" minimum thickness  
**Material Strength:** 36ksi minimum yield strength  
**ASTM:** A36

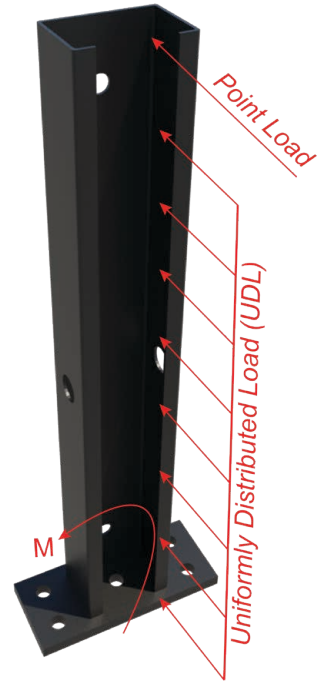

### Pony Wall Heavy (PW) Allowable Loads

Member designation	Pony Wall Length (in)	Anchors to structure	Strength based capacity (ASD)		
			Allowable moment, in-lbs	Max point load @ cantilever end, lbs	Max uniform live (UDL) load, lbs/ft
Pony Wall	24	Designed by others	18,316	763	763
	36			509	339
	48			382	191
	60			305	122

#### Notes:

- ClarkDietrich Pony Wall Heavy (PW) is intended to support out-of-plane loading of cantilevered partial wall systems that are unsupported at the top track.
- Out-of-plane loads are transferred to the floor system through the base-plate, which is welded to Pony Wall Heavy member.
- ClarkDietrich Pony Wall Heavy (PW) may be used in place of standard framing members, or in conjunction with them to frame the wall.
- Listed allowable loads are based on Allowable Stress Design (ASD).
- Base connection between ClarkDietrich Pony Wall Heavy and support structure are designed by others.
- Serviceability/deflection needs to be checked separately. To do this, designers need to consider deflection of strut (effective moment of inertia = 0.7739 in<sup>4</sup>) and deflection due to rotation at the base (see rotational stiffness table).
- Listed maximum point load at cantilever end calculated using maximum allowable moment. Similarly, listed maximum uniformly distributed load calculated using maximum allowable moment. When both point load and uniform loads are applied, combined loads should be limited to maximum allowable moment.
- It is the responsibility of the designer to properly detail connections on the contract drawings.

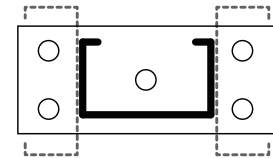

Uniformly distributed loads are based on framing members placed on each side of the Pony Wall

### Pony Wall Heavy (PW) Allowable Loads w/Anchors

Member designation	Anchors to structure	Strength based capacity (ASD)	
		No. of Anchors to Structure	Allowable base moment, in-lbs
PW24/PW36/PW48/P60	1/2" $\phi$ Hilti KB1 Expansion Anchor (3-5/8" Nominal Embedment, 3000psi Uncracked Concrete)	1	3,403
		4	10,840

#### Notes:

- ClarkDietrich Pony Wall Heavy is intended to support out-of-plane loading of cantilevered partial wall systems that are unsupported at the top track.
- Out-of-plane loads are transferred to the floor system through base-plate, which is welded to Pony Wall Heavy member.
- ClarkDietrich Pony Wall Heavy (PW) may be used in place of standard framing members, or in conjunction with them to frame the wall.
- Listed allowable loads are based on Allowable Stress Design (ASD).
- Serviceability/deflection needs to be checked separately. To do this, designers need to consider deflection of strut (effective moment of inertia = 0.7739 in<sup>4</sup>) and deflection due to rotation at the base (see rotational stiffness table).
- Above listed capacities w/anchors shall be used only when using 1/2"  $\phi$  Hilti KB1 Expansion Anchors to concrete.
- Other anchors may be used to achieve full Pony Wall Heavy capacity, but must be designed separately.
- Above listed capacities have not been increased for wind, seismic, or other factors.
- Hilti is a registered trademark of Hilti Aktiengesellschaft Corporation.
- It is the designer's responsibility to check for minimum concrete edge distance and minimum concrete thickness when using anchors.
- It is the responsibility of the designer to properly detail connections on the contract drawings.



(1) Anchor to structure



(4) Anchors to structure

## Pony Wall Heavy (PW) Allowable Loads

### UNIFORMLY DISTRIBUTED LOAD

#### MATERIAL SPECIFICATION:

##### **PONY WALL HEAVY STUD**

**Material Thickness:** 12ga (97mils), 0.1017" design thickness  
**Material Strength:** Structural grade 50, 50ksi minimum yield strength  
**ASTM:** A1011

##### **PONY WALL HEAVY BASE PLATE**

**Material Thickness:** 1/2" minimum thickness  
**Material Strength:** 36ksi minimum yield strength  
**ASTM:** A36

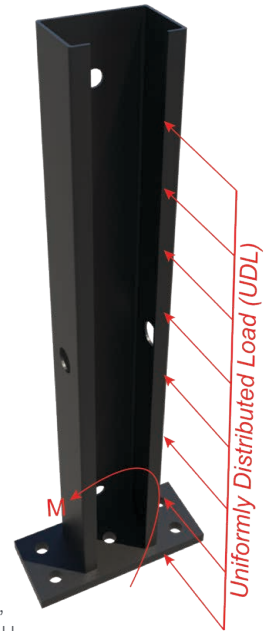

## Pony Wall Heavy (PW) Allowable Loads

### UNIFORMLY DISTRIBUTED LOAD

Member designation	Pony Wall Length (in)	Uniformly distributed load, lbs/ft					Moment (ASD) due to uniform load, in-lbs				
		L/720*	L/360*	L/240*	L/180*	Max	L/720*	L/360*	L/240*	L/180*	Max
Pony Wall Heavy	24	220	440	661	763	763	5,285	10,569	15,854	18,316	18,316
	36	65	130	196	261	339	3,523	7,046	10,569	14,093	18,316
	48	28	55	83	110	191	2,642	5,285	7,927	10,569	18,316
	60	14	28	42	56	122	2,114	4,228	6,342	8,456	18,316

\* The values shown are based on deflection of the strut member only which has an effective moment of inertia = 0.7739 in<sup>4</sup>. For overall assembly deflection, designers also need to consider deflection due to rotation at the base. The values needed for this additional analysis are provided in the rotational stiffness table.

#### Notes:

- ClarkDietrich Pony Wall Heavy is intended to support out-of-plane loading of cantilevered partial wall systems that are unsupported at the top track.
- Out-of-plane loads are transferred to the floor system through the base-plate, which is welded to Pony Wall member.
- ClarkDietrich Pony Wall Heavy (PW) may be used in place of standard framing members, or in conjunction with them to frame the wall.
- Listed allowable loads are based on Allowable Stress Design (ASD).
- Base connection between ClarkDietrich Pony Wall Heavy and support structure are designed by others.
- Serviceability/deflection needs to be checked separately. To do this, designers need to consider deflection of strut (effective moment of inertia = 0.7739 in<sup>4</sup>) and deflection due to rotation at the base (see rotational stiffness table).
- Listed maximum point load at cantilever end calculated using maximum allowable moment. When both point load and uniform loads are applied, combined loads should be limited to maximum allowable moment.
- It is the responsibility of the designer to properly detail connections on the contract drawings.

## Pony Wall Heavy (PW) Allowable Loads w/Anchors

### UNIFORMLY DISTRIBUTED LOAD

Member designation	Pony Wall length, in	Anchors to structure	No. of Anchors	Uniformly distributed loads, lbs/ft					Allowable base moment, in-lbs				
				L/720	L/360	L/240	L/180	Max	L/720	L/360	L/240	L/180	Max
PW24	24	1/2" $\phi$ Hilti KB1 Expansion Anchor (3-5/8" Nominal Embedment, 3000psi Uncracked concrete)	1	142	142	142	142	142	3,403	3,403	3,403	3,403	3,403
			4	220	440	452	452	452	5,285	10,569	10,840	10,840	10,840
PW36	36		1	63	63	63	63	63	3,403	3,403	3,403	3,403	3,403
			4	65	130	196	201	201	3,523	7,046	10,569	10,840	10,840
PW48	48		1	28	35	35	35	35	2,642	3,403	3,403	3,403	3,403
			4	28	55	83	110	113	2,642	5,285	7,927	10,569	10,840
PW60	60		1	14	23	23	23	23	2,114	3,403	3,403	3,403	3,403
			4	14	28	42	56	72	2,114	4,228	6,342	8,456	10,840

\* The values shown are based on deflection of the strut member only which has an effective moment of inertia = 0.7739 in<sup>4</sup>. For overall assembly deflection, designers also need to consider deflection due to rotation at the base. The values needed for this additional analysis are provided in the rotational stiffness table.

#### Notes:

- ClarkDietrich Pony Wall Heavy is intended to support out-of-plane loading of cantilevered partial wall systems that are unsupported at the top track.
- Out-of-plane loads are transferred to the floor system through base-plate, which is welded to Pony Wall member.
- ClarkDietrich Pony Wall Heavy (PW) may be used in place of standard framing members, or in conjunction with them to frame the wall.
- Listed allowable loads are based on Allowable Stress Design (ASD).
- Serviceability/deflection needs to be checked separately. To do this, designers need to consider deflection of strut (effective moment of inertia = 0.7739 in<sup>4</sup>) and deflection due to rotation at the base (see rotational stiffness table).
- Above listed capacities w/anchors shall be used only when using 1/2"  $\phi$  Hilti KB1 Expansion Anchors to concrete.
- Other anchors may be used to achieve full Pony Wall Heavy capacity, but must be designed separately.
- Above listed capacities have not been increased for wind, seismic, or other factors.
- Hilti is a registered trademark of Hilti Aktiengesellschaft Corporation.
- It is the designer's responsibility to check for minimum concrete edge distance and minimum concrete thickness when using anchors.
- It is the responsibility of the designer to properly detail connections on the contract drawings.

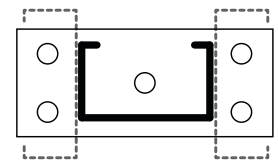

Uniformly distributed loads are based on framing members placed on each side of the Pony Wall



(1) Anchor to structure



(4) Anchors to structure

## Pony Wall Lite (16ga)

### Partial wall framing connection to the floor

The ClarkDietrich Pony Wall Lite is intended to support out-of-plane loading of cantilevered partial wall systems that are unsupported at the top track. Out-of-plane loads are transferred to the floor system through the base-plate, which is welded to the Pony Wall Lite stud member.

### PRODUCT DIMENSIONS

LGPW24 = 23-5/8" tall with 2-3/8" wide x 5-1/2" long plate  
 LGPW36 = 35-5/8" tall with 2-3/8" wide x 5-1/2" long plate  
 LGPW48 = 47-5/8" tall with 2-3/8" wide x 5-1/2" long plate  
 LGPW60 = 59-5/8" tall with 2-3/8" wide x 5-1/2" long plate

### MATERIAL SPECIFICATIONS

**Plate Material:** ASTM A36, 3/8" thick hot rolled steel

**Stud Material:** ASTM A1011 SS Grade 50, 50ksi (340 MPa)  
 16ga (54mils), 0.0566" Design thickness, 0.0538" Min. thickness

**Coating:** Envirocron® Powder Coating

**Packaging:** Individually

**ASTM:** A36, A1011

### INSTALLATION

Install the Pony Wall Lite inside the track or directly to the floor structure. Anchor to the floor as designed by EOR. Attach the studs to both flanges of the Pony Wall Lite. A minimum of 2-1/2" stud member can be used.

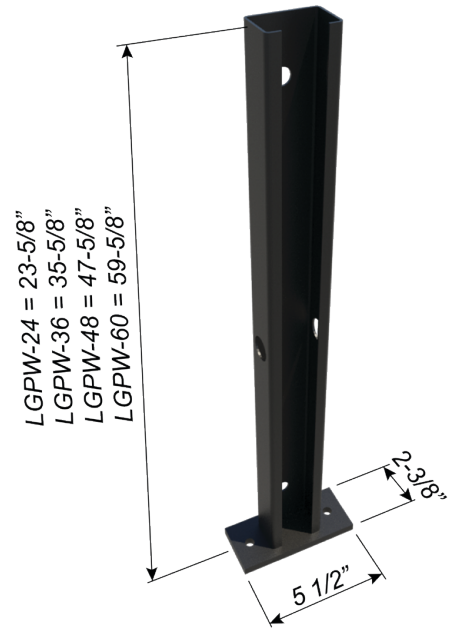

### Pony Wall Lite (LGPW)

Product code	Thickness		Size (in)	Packaging
	Mils (Gauge)	Design thickness (in)		
LGPW24	54mils (16ga)	0.0566	23-5/8"	Individually
LGPW36			35-5/8"	
LGPW48			47-5/8"	
LGPW60			59-5/8"	

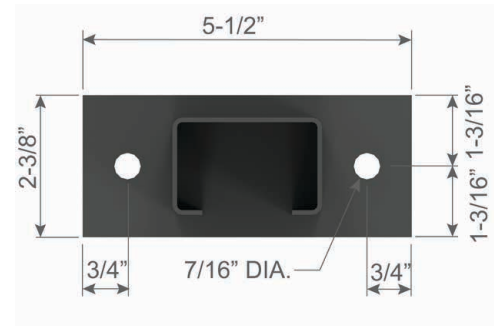

**Pony Wall Lite (LGPW) Allowable Loads** **CONCENTRATED LOAD AT FREE END**

**MATERIAL SPECIFICATION:**

**PONY WALL LITE STUD**

**Material Thickness:** 16ga (54mils), 0.0566" design thickness  
**Material Strength:** Structural grade 50, 50ksi minimum yield strength  
**ASTM:** A1011

**PONY WALL LITE BASE PLATE**

**Material Thickness:** 3/8" minimum thickness  
**Material Strength:** 36ksi minimum yield strength  
**ASTM:** A36



Pony Wall Lite (LGPW) Allowable Loads		CONCENTRATED LOAD AT FREE END					
Member designation	Pony Wall Length (in)	Max point load @ cantilever end, lbs			Moment (ASD) due to point load, in-lbs		
		L/240	L/180	Max	L/240	L/180	Max
Pony Wall Lite	24	86	115	177	2074	2766	4253
	36	38	51	118	1383	1844	4253
	48	22	29	89	1037	1383	4253
	60	14	18	71	830	1106	4253

**Notes:**

- 1 Pony Wall Lite is intended to support out-of-plane loading of cantilevered partial wall systems that are unsupported at the top track.
- 2 Out-of-plane loads are transferred to the floor system through the base-plate, which is welded to Pony Wall Lite member.
- 3 Pony Wall Lite may be used in place of standard framing members, or in conjunction with them to frame the wall.
- 4 Listed allowable loads are based on Allowable Stress Design (ASD).
- 5 Base connection between Pony Wall Lite and support structure are designed by others.
- 6 For serviceability/deflection calculations of Pony Wall Lite, use effective moment of inertia = 0.1350 in<sup>4</sup> (54mils), 0.1626in<sup>4</sup> (68mils)
- 7 Listed maximum point load @ cantilever end calculated using maximum allowable moment. When both point load and uniform loads are applied, combined loads should be limited to maximum allowable moment.
- 8 It is the responsibility of the designer to properly detail connections on the contract drawings.

**Pony Wall Lite (LGPW) Allowable Loads w/Anchors** **CONCENTRATED LOAD AT FREE END**

Member designation	Pony Wall length, in	Anchors to structure	No. of Anchors	Max point load @ cantilever end, lbs			Allowable base moment, in-lbs		
				L/240	L/180	Max	L/240	L/180	Max
LGPW24	24	3/8" $\phi$ Hilti Kwik Bolt-3 (2-3/8" Nominal Embedment, 3000psi Uncracked concrete)	2	83	83	83	1984	1984	1984
LGPW36	36			38	51	55	1383	1844	1984
LGPW48	48			22	29	41	1037	1383	1984
LGPW60	60			14	18	33	830	1106	1984

**Notes:**

- 1 Pony Wall Lite is intended to support out-of-plane loading of cantilevered partial wall systems that are unsupported at the top track.
- 2 Out-of-plane loads are transferred to the floor system through base-plate, which is welded to Pony Wall Lite member.
- 3 Pony Wall Lite may be used in place of standard framing members, or in conjunction with them to frame the wall.
- 4 Listed allowable loads are based on Allowable Stress Design (ASD).
- 5 For serviceability/deflection calculations of Pony Wall Lite, use effective moment of inertia = 0.1350 in<sup>4</sup> (54mils), 0.1626in<sup>4</sup> (68mils)
- 6 Above listed capacities w/anchors shall be used only when using 3/8"  $\phi$  Hilti Kwik Bolt-3 anchors to concrete.
- 7 Other anchors may be used to achieve full Pony Wall Lite capacity, but must be designed separately.
- 8 Above listed capacities have not been increased for wind, seismic, or other factors.
- 9 Hilti is a registered trademark of Hilti Aktiengesellschaft Corporation.
- 10 It is the designer's responsibility to check for minimum concrete edge distance and minimum concrete thickness when using anchors.
- 11 It is the responsibility of the designer to properly detail connections on the contract drawings.



(2) Anchors to structure

## Pony Wall Lite (16ga)

### Pony Wall Lite (LGPW) Allowable Loads

### MAXIMUM ALLOWABLE LOADS

**MATERIAL SPECIFICATION:**

**PONY WALL LITE STUD**

**Material Thickness:** 16ga (54mils), 0.0566" design thickness  
**Material Strength:** Structural grade 50, 50ksi minimum yield strength  
**ASTM:** A1011

**PONY WALL LITE BASE PLATE**

**Material Thickness:** 3/8" minimum thickness  
**Material Strength:** 36ksi minimum yield strength  
**ASTM:** A36

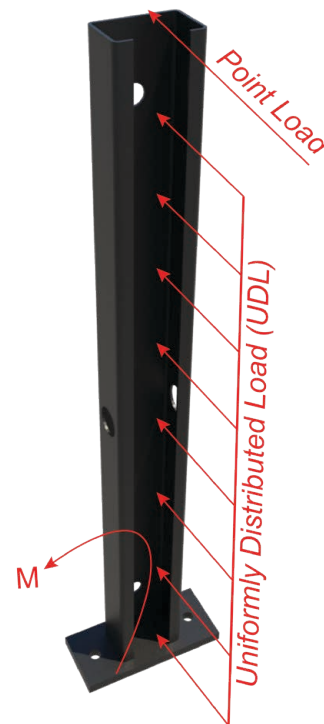

### Pony Wall Lite (LGPW) Allowable Loads

Member designation	Pony Wall Length (in)	Anchors to structure	Strength based capacity (ASD)		
			Allowable moment, in-lbs	Max point load @ cantilever end, lbs	Max uniform live (UDL) load, lbs/ft
Pony Wall Lite	24	Designed by others	4253	177	177
	36			118	79
	48			89	44
	60			71	28

**Notes:**

- 1 Pony Wall Lite is intended to support out-of-plane loading of cantilevered partial wall systems that are unsupported at the top track.
- 2 Out-of-plane loads are transferred to the floor system through the base-plate, which is welded to Pony Wall Lite member.
- 3 Pony Wall Lite may be used in place of standard framing members, or in conjunction with them to frame the wall.
- 4 Listed allowable loads are based on Allowable Stress Design (ASD).
- 5 Base connection between Pony Wall Lite and support structure are designed by others.
- 6 For serviceability/deflection calculations of Pony Wall Lite, use effective moment of inertia = 0.1350 in<sup>4</sup> (54mils), 0.1626in<sup>4</sup> (68mils)
- 7 Listed maximum point load @ cantilever end calculated using maximum allowable moment. Similarly, listed maximum uniformly distributed load calculated using maximum allowable moment. When both point load and uniform loads are applied, combined loads should be limited to maximum allowable moment.
- 8 It is the responsibility of the designer to properly detail connections on the contract drawings.

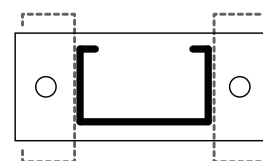

Uniformly distributed loads are based on framing members placed on each side of the Pony Wall

### Pony Wall Lite (LGPW) Allowable Loads w/Anchors

Member designation	Anchors to structure	Strength based capacity (ASD)	
		No. of Anchors to Structure	Allowable base moment, in-lbs
LGPW24, LGPW36, LGPW48, LGPW60	3/8" $\phi$ Hilti Kwik Bolt-3 (2-3/8" Nominal Embedment, 3000psi Uncracked concrete)	2	1984

**Notes:**

- 1 Pony Wall Lite is intended to support out-of-plane loading of cantilevered partial wall systems that are unsupported at the top track.
- 2 Out-of-plane loads are transferred to the floor system through base-plate, which is welded to Pony Wall Lite member.
- 3 Pony Wall Lite may be used in place of standard framing members, or in conjunction with them to frame the wall.
- 4 Listed allowable loads are based on Allowable Stress Design (ASD).
- 5 For serviceability/deflection calculations of Pony Wall Lite, use effective moment of inertia = 0.1350 in<sup>4</sup> (54mils), 0.1626in<sup>4</sup> (68mils)
- 6 Above listed capacities w/anchors shall be used only when using 3/8"  $\phi$  Hilti Kwik Bolt-3 anchors to concrete.
- 7 Other anchors may be used to achieve full Pony Wall Lite capacity, but must be designed separately.
- 8 Above listed capacities have not been increased for wind, seismic, or other factors.
- 9 Hilti is a registered trademark of Hilti Aktiengesellschaft Corporation.
- 10 It is the designer's responsibility to check for minimum concrete edge distance and minimum concrete thickness when using anchors.
- 11 It is the responsibility of the designer to properly detail connections on the contract drawings.



(2) Anchors to structure



**Pony Wall Lite (LGPW) Allowable Loads** **UNIFORMLY DISTRIBUTED LOAD**

**MATERIAL SPECIFICATION:**

**PONY WALL LITE STUD**

**Material Thickness:** 16ga (54mils), 0.0566" design thickness  
**Material Strength:** Structural grade 50, 50ksi minimum yield strength  
**ASTM:** A1011

**PONY WALL LITE BASE PLATE**

**Material Thickness:** 3/8" minimum thickness  
**Material Strength:** 36ksi minimum yield strength  
**ASTM:** A36

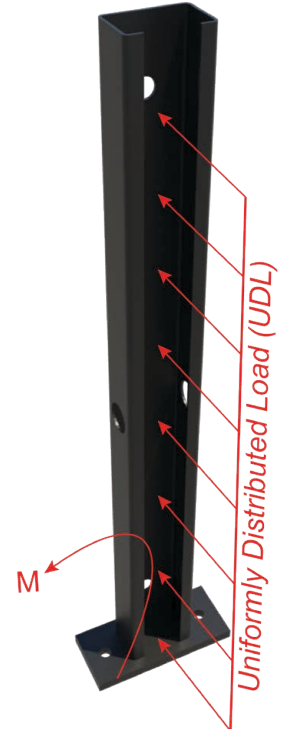

Pony Wall Lite (LGPW) Allowable Loads		UNIFORMLY DISTRIBUTED LOAD					
Member designation	Pony Wall Length (in)	Uniformly distributed load, lbs/ft			Moment (ASD) due to uniform load, in-lbs		
		L/240	L/180	Max	L/240	L/180	Max
Pony Wall Lite	24	115	154	177	2766	3688	4253
	36	34	46	79	1844	2458	4253
	48	14	19	44	1383	1844	4253
	60	7	10	28	1106	1475	4253

**Notes:**

- 1 Pony Wall Lite is intended to support out-of-plane loading of cantilevered partial wall systems that are unsupported at the top track.
- 2 Out-of-plane loads are transferred to the floor system through the base-plate, which is welded to Pony Wall Lite member.
- 3 Pony Wall Lite may be used in place of standard framing members, or in conjunction with them to frame the wall.
- 4 Listed allowable loads are based on Allowable Stress Design (ASD).
- 5 Base connection between Pony Wall Lite and support structure are designed by others.
- 6 For serviceability/deflection calculations of Pony Wall Lite, use effective moment of inertia = 0.1350 in<sup>4</sup> (54mils), 0.1626in<sup>4</sup> (68mils)
- 7 Listed maximum uniformly distributed load calculated using maximum allowable moment. When both point load and uniform loads are applied, combined loads should be limited to maximum allowable moment.
- 8 It is the responsibility of the designer to properly detail connections on the contract drawings.

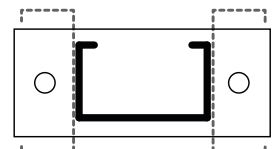

Uniformly distributed loads are based on framing members placed on each side of the Pony Wall

Pony Wall Lite (LGPW) Allowable Loads w/Anchors		UNIFORMLY DISTRIBUTED LOAD							
Member designation	Pony Wall length, in	Anchors to structure	No. of Anchors	Uniformly distributed loads, lbs/ft			Allowable base moment, in-lbs		
				L/240	L/180	Max	L/240	L/180	Max
LGPW24	24	3/8" $\phi$ Hilti Kwik Bolt-3 (2-3/8" Nominal Embedment, 3000psi Uncracked concrete)	2	83	83	83	1984	1984	1984
LGPW36	36			34	37	37	1844	1984	1984
LGPW48	48			14	19	21	1383	1844	1984
LGPW60	60			7	10	13	1106	1475	1984



(2) Anchors to structure

**Notes:**

- 1 Pony Wall Lite is intended to support out-of-plane loading of cantilevered partial wall systems that are unsupported at the top track.
- 2 Out-of-plane loads are transferred to the floor system through base-plate, which is welded to Pony Wall Lite member.
- 3 Pony Wall Lite may be used in place of standard framing members, or in conjunction with them to frame the wall.
- 4 Listed allowable loads are based on Allowable Stress Design (ASD).
- 5 For serviceability/deflection calculations of Pony Wall Lite, use effective moment of inertia = 0.1350 in<sup>4</sup> (54mils), 0.1626in<sup>4</sup> (68mils)
- 6 Above listed capacities w/anchors shall be used only when using 3/8"  $\phi$  Hilti Kwik Bolt-3 anchors to concrete.
- 7 Other anchors may be used to achieve full Pony Wall Lite capacity, but must be designed separately.
- 8 Above listed capacities have not been increased for wind, seismic, or other factors.
- 9 Hilti is a registered trademark of Hilti Aktiengesellschaft Corporation.
- 10 It is the designer's responsibility to check for minimum concrete edge distance and minimum concrete thickness when using anchors.
- 11 It is the responsibility of the designer to properly detail connections on the contract drawings.

## Fixed Universal Slip Clip

### 10 and 12 gauge fixed universal slip clip.

The clips are available in standard lengths of 6" and 8" in 12 and 10 gauge. They are ideal for medium to larger standoff conditions. FUS clips install quickly and provide adjustable standoff to ensure a plumb wall plane.

- Eliminates shims and scabs.
- Fast, one-piece universal installation. No left- or right-handed clips.
- Higher capacities when used in applications where significantly higher capacities are required.

### PRODUCT DIMENSIONS

Lengths: 6" or 8"

### MATERIAL SPECIFICATIONS

**Gauge:** 12 gauge (97mils)

**Design Thickness:** 0.1017 inches

**Gauge:** 10 gauge (118mils)

**Design Thickness:** 0.1242 inches

**Coating:** G90 (Z275 hot-dipped galvanized coating)

**Material:** Structural Grade 50 Type H (ST50H), 50ksi

**ASTM:** A653/A653M, ASTM A1003

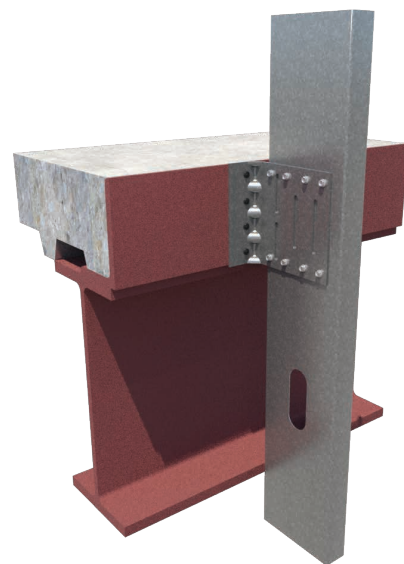
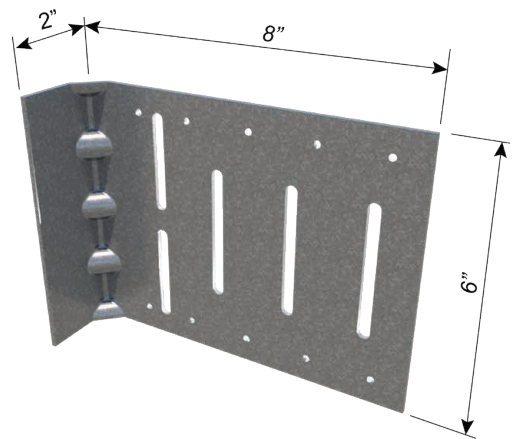
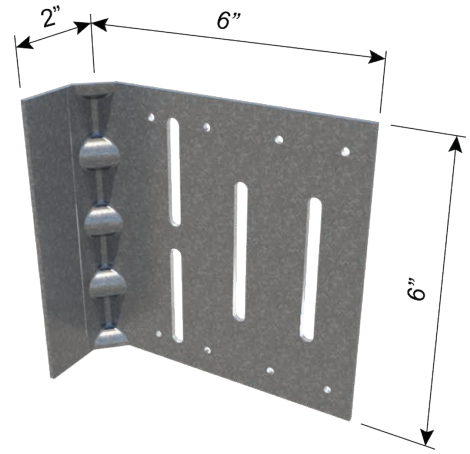

### Fixed Universal Slip Clip (FUS6, FUS8)

Product code	Thickness		Clip length (in)	Packaging Pcs./Box
	Mils (Gauge)	Design thickness (in)		
FUS6-97	97mils (12ga)	0.1017	6	10
FUS8-97			8	10
FUS6-118	118mils (10ga)	0.1242	6	10
FUS8-118			8	10

**INSTALLATION**

Connections to the building can be made with screws, welds powder-actuated fasteners. Mechanical fasteners shall be located on the embossed marks given on the scored line of the 2" flange. Attach building anchors to the structure according to the manufacturer's instructions. Anchors shall be installed through the embossments on the scored line of the clip as shown on the attached drawings. In no case shall anchors be installed more than 3/4" from the bend on the short leg of the clip. In cases of discrepancy between this information and the Design Engineer's details, the Design Engineer's details shall be followed.

**For a Rigid Connection:**

Attach the FUS clip to cold-formed steel framing members using (8) #12 self-tapping screws (not included) for the FUS6 clip and (10) #12 self-drilling screws (not included) for the FUS8 clip through the clip holes into the steel framing. For a rigid connection, screws should not be installed in any of the slotted holes.

Fixed Universal Slip Clip Design Capacities					RIGID CONNECTIONS			
Product code	Clip thickness mils (gauge)	Clip length (in)	No. of #12 screws to framing	Stud thickness mils (gauge)	Capacities (lbs)			
					In-Plane	Tension	Compression	Shear
					F1	F2	F3	F4
FUS6-97	97mils (12ga)	6	8	33mils (20ga)	162	1550	1258	921
				43mils (18ga)	239	1974	1716	1555
				54mils (16ga)	323	2439	2217	2250
				68mils (14ga)	476	2468	2789	2402
				97mils (12ga)	793	2529	3971	2718
FUS8-97	97mils (12ga)	8	10	33mils (20ga)	162	1550	1258	921
				43mils (18ga)	250	1974	1652	1300
				54mils (16ga)	346	2439	2084	1716
				68mils (14ga)	513	2469	2638	2088
				97mils (12ga)	859	2531	3784	2857
FUS6-118	118mils (10ga)	6	8	33mils (20ga)	171	1538	1470	921
				43mils (18ga)	229	2358	2107	1555
				54mils (16ga)	294	3255	2805	2250
				68mils (14ga)	458	3286	3515	2402
				97mils (12ga)	799	3351	4982	2718
FUS8-118	118mils (10ga)	8	10	33mils (20ga)	171	1538	1470	921
				43mils (18ga)	241	2358	2216	1300
				54mils (16ga)	319	3255	3033	1716
				68mils (14ga)	474	3286	3672	2088
				97mils (12ga)	794	3351	4995	2857

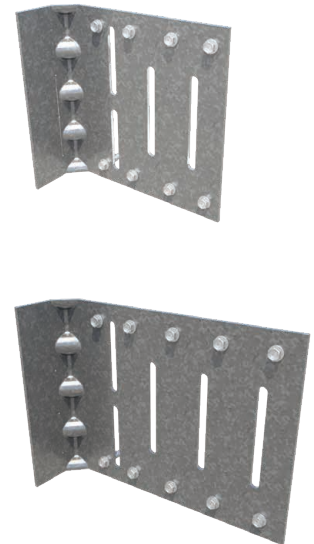

**Notes:**

- 1 Tabulated loads are based on testing with 600S162 CFS framing members.
- 2 Tabulated loads are based on single test conducted with two clips per test.
- 3 FUS was tested in compliance with ICC-ES AC-261 (2019) listed test setups.
- 4 #12 self-tapping screws were used to attach clips to framing members.
- 5 The ultimate screw shear strength and screw tension strength for #12 screws shall be at least 2000-lbs, and 2325-lbs respectively.
- 6 The screw strength capacities are based of CFSEI Tech Note (F701-12).
- 7 Allowable loads have not been increased for seismic or wind.

Product Detail

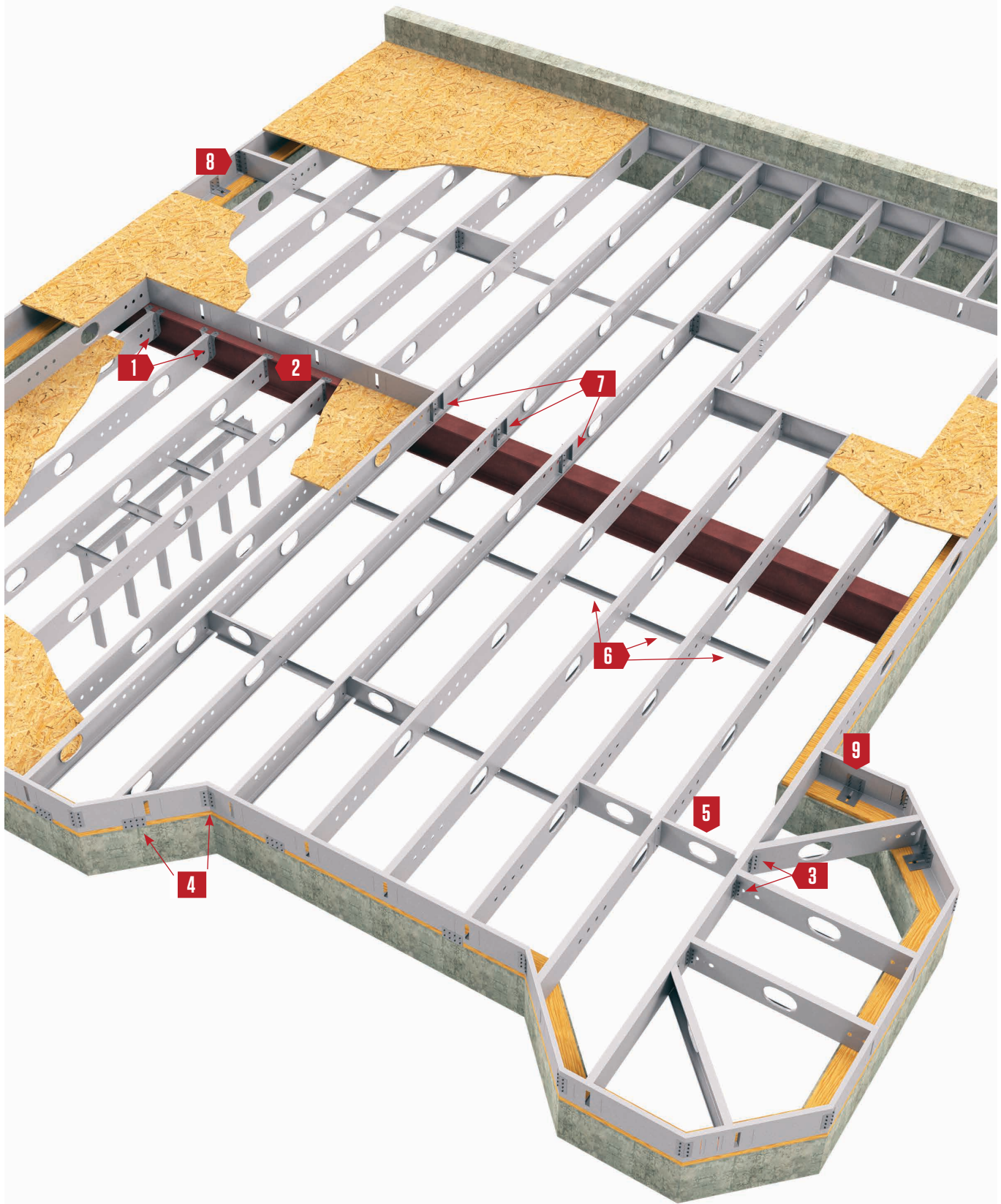

**1** **Bridle Hanger**  
pages 122-123

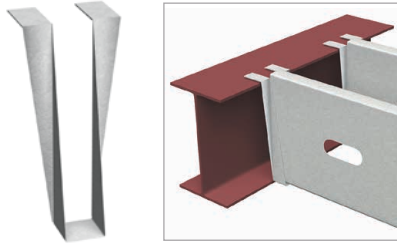

**2** **Universal Joist Hanger**  
pages 124-126

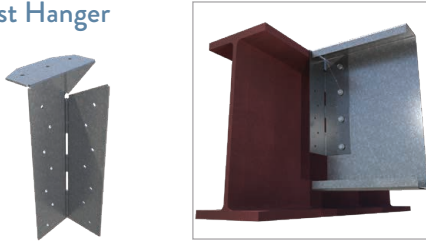

**3** **Skewable Angle**  
page 128-129

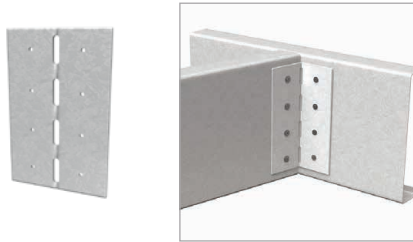

**4** **TradeReady® Rim Track Splice Plate**  
pages 130-131



**5** **TradeReady® Floor Joist Blocking**  
page 132

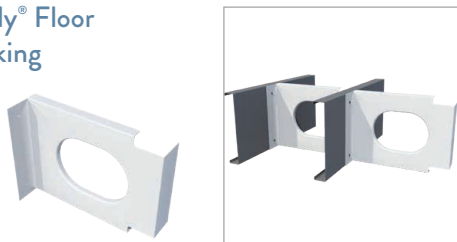

**6** **TradeReady® Structural Bridging**  
page 133

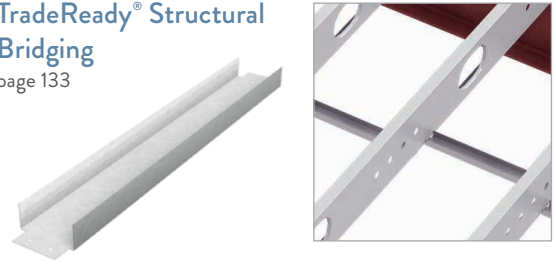

**7** **EasyClip™ QuickTwist™ Web Stiffener**  
pages 134-135

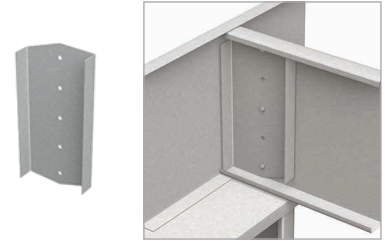

**8** **EasyClip E-Series™ Support Clip**  
pages 136-137

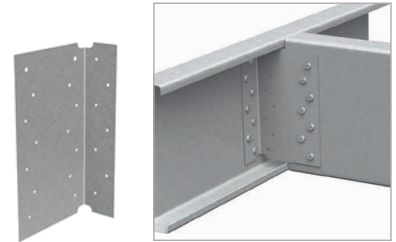

**9** **Custom Fabricated Clips & Connections**  
pages 2-3



## Bridle Hanger

Attach floor joists to structural steel beams or wood ledgers.

Bridle hangers are commonly used to attach light-gauge C-joists to structural steel beams or wood ledgers. Connections can be made with screws, powder-actuated fasteners, drill-in concrete anchors or welding. Single- and double-wide bridle hangers are available.

### PRODUCT DIMENSIONS

Widths: 2-1/16" or 4-1/8"

Heights: 6", 8", 10" or 12"

### MATERIAL SPECIFICATIONS

Gauge: 14 gauge (68mils)

Design Thickness: 0.0713 inches

Gauge: 12 gauge (97mils)

Design Thickness: 0.1017 inches

Coating: G90

ASTM: A653/A653M

### INSTALLATION

Attach bridle hanger to the primary frame as specified. When welding the hanger to the primary frame, a minimum of 2" fillet weld on each top flange is required. Distribute the weld equally on both top flanges. Uplift loads do not apply to weld-on applications. Special considerations must be taken when welding galvanized steel. Place joist into hanger and secure with fasteners. If bridle hanger is less than beam depth, provide back blocking.

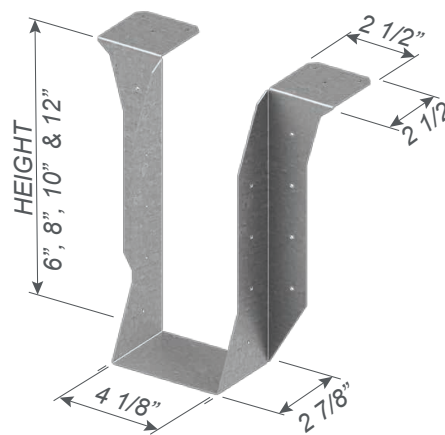
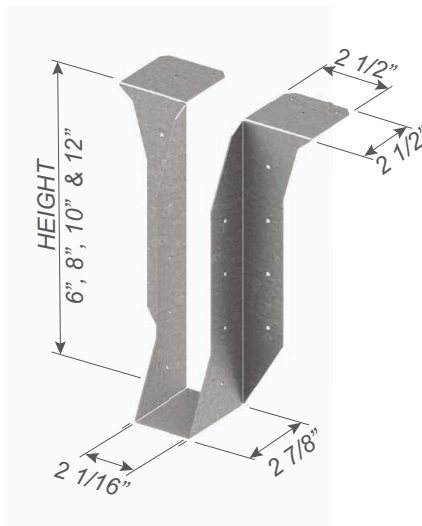

### Bridle Hangers (CDBV, CDMB)

Product code	Thickness		Depth (H) (in)	Width (W) (in)	Packaging Pcs./Carton
	Mils (Gauge)	Design thickness (in)			
CDBV 1-5/8 x 6	68mils (14ga)	0.0713	6	1-5/8	20
CDBV 1-5/8 x 8			8		20
CDBV 1-5/8 x 10			10		15
CDBV 1-5/8 x 12			12		15
CDBV 2 x 6	68mils (14ga)	0.0713	6	2-1/16	20
CDBV 2 x 8			8		20
CDBV 2 x 10			10		15
CDBV 2 x 12			12		15
CDBV 4 x 6	68mils (14ga)	0.0713	6	4-1/8	15
CDBV 4 x 8			8		15
CDBV 4 x 10			10		15
CDBV 4 x 12			12		15
CDMB 1-5/8 x 6	97mils (12ga)	0.1017	6	1-5/8	20
CDMB 1-5/8 x 8			8		20
CDMB 1-5/8 x 10			10		15
CDMB 1-5/8 x 12			12		15
CDMB 2 x 6	97mils (12ga)	0.1017	6	2-1/16	20
CDMB 2 x 8			8		20
CDMB 2 x 10			10		15
CDMB 2 x 12			12		15
CDMB 4 x 6	97mils (12ga)	0.1017	6	4-1/8	15
CDMB 4 x 8			8		15
CDMB 4 x 10			10		15
CDMB 4 x 12			12		15

### Bridle Hangers (CDBV, CDMB)

Product code	Member Designation (in)		Screw Configuration / Hanger				ASD Loads (lb)	
	Width	Height	Header		Joist	Uplift	Down	
			Flange	Web	Web			
CDBV 68mils (14ga)	1-11/16"	6	(6) #10	(4) #12	(2) #12	1146	1443	
		8	(6) #10	(6) #12	(3) #12	1929	2193	
		10	(6) #10	(8) #12	(4) #12	2314	2620	
		12	(6) #10	(10) #12	(5) #12	2873	3319	
		6	(4) x 2" fillet weld [each side of top flange]	(2) #12	—	1554		
		8		(3) #12	—	2089		
	10	(4) #12		—	2089			
	12	(5) #12		—	2089			
	2-1/16"	6	(6) #10	(4) #12	(2) #12	1146	1443	
		8	(6) #10	(6) #12	(3) #12	1929	2193	
		10	(6) #10	(8) #12	(4) #12	2314	2620	
		12	(6) #10	(10) #12	(5) #12	2873	3319	
		6	(4) x 2" fillet weld [each side of top flange]	(2) #12	—	1554		
		8		(3) #12	—	2089		
	10	(4) #12		—	2089			
	12	(5) #12		—	2089			
	4-1/8"	6	(6) #10	(4) #12	(4) #12	2293	2886	
		8	(6) #10	(6) #12	(6) #12	3699	4197	
		10	(6) #10	(8) #12	(8) #12	4629	5239	
		12	(6) #10	(10) #12	(10) #12	5025	6054	
		6	(4) x 2" fillet weld [each side of top flange]	(4) #12	—	3108		
		8		(6) #12	—	3771		
	10	(8) #12		—	5055			
	12	(10) #12		—	5104			
CDMB 97mils (12ga)	1-11/16"	6	(6) #10	(4) #14	(2) #14	1545	2032	
		8	(6) #10	(6) #14	(3) #14	2370	2687	
		10	(6) #10	(8) #14	(4) #14	3166	3474	
		12	(6) #10	(10) #14	(5) #14	3927	4950	
		6	(4) x 2" fillet weld [each side of top flange]	(2) #14	—	2032		
		8		(3) #14	—	2462		
	10	(4) #14		—	2993			
	12	(5) #14		—	2993			
	2-1/16"	6	(6) #10	(4) #14	(2) #14	1545	2032	
		8	(6) #10	(6) #14	(3) #14	2370	2687	
		10	(6) #10	(8) #14	(4) #14	3166	3474	
		12	(6) #10	(10) #14	(5) #14	3927	4950	
		6	(4) x 2" fillet weld [each side of top flange]	(2) #14	—	2032		
		8		(3) #14	—	2462		
	10	(4) #14		—	2993			
	12	(5) #14		—	2993			
	4-1/8"	6	(6) #10	(4) #14	(4) #14	3090	4064	
		8	(6) #10	(6) #14	(6) #14	4332	5558	
		10	(6) #10	(8) #14	(8) #14	6332	6949	
		12	(6) #10	(10) #14	(10) #14	7771	8948	
		6	(4) x 2" fillet weld [each side of top flange]	(4) #14	—	4064		
		8		(6) #14	—	4789		
	10	(8) #14		—	6078			
	12	(10) #14		—	6489			

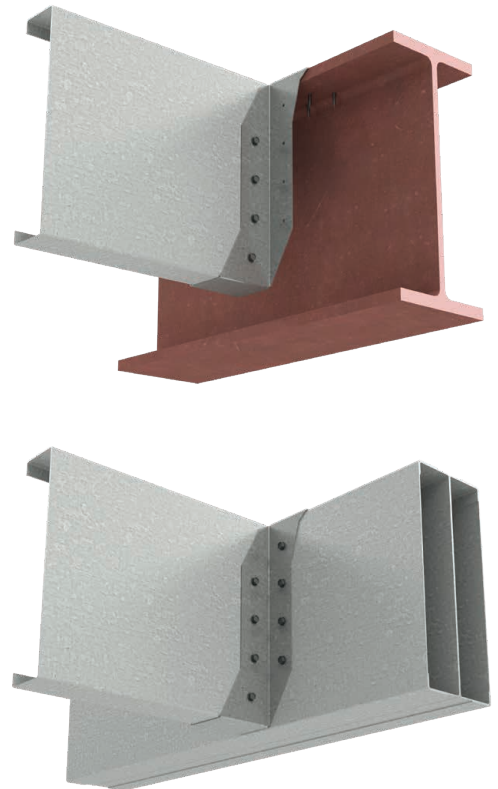

**Notes:**

- 1 Screws shall be installed through the pre-drilled holes in the hanger or as detailed by the designer.
- 2 CFS joist shall be laterally braced per designer specification.
- 3 An 1/8" gap shall be maintained between end of the joist and the supporting header.
- 4 CFS header must be braced to prevent web crippling/buckling per designer specification.
- 5 CFS header must have full bearing of 2-1/2" flange-depth.
- 6 The ultimate screw shear strength for #12 screws shall be at least 2330 lbs.
- 7 The ultimate screw shear strength for #14 screws shall be at least 3048 lbs.
- 8 The screw shear strength capacities are based on CFSEI Tech Note (F701-12).
- 9 Allowable loads have not been increased for seismic or wind.
- 10 Contact ClarkDietrich Engineering Services for technical assistance.

## Universal Joist Hanger

### Floor joist connection to structural steel beams or CFS headers

The Universal Joist Hangers (UJH) 68mils (14ga) are used to connect joists to CFS headers (with screws, welds or PAF fasteners) and steel I-beams (with welds or PAF fasteners). The UJH is sized to fit joist sizes from 8" to 14" deep. Also available in 97mils (12ga).

### PRODUCT DIMENSIONS

**Dimensions:** 4" x 7-1/2" long

**Packaging:** (25) pieces per bucket

### MATERIAL SPECIFICATIONS

**Gauge:** 14 gauge (68mils)

**Design Thickness:** 0.0713 inches

**Yield Strength:** Structural Grade 50

Type H (ST50H), 50ksi

**Coating:** G90

**ASTM:** A1003, ASTM A653

**Gauge:** 12 gauge (97mils)

**Design Thickness:** 0.1017 inches

**Yield Strength:** Structural Grade 50

Type H (ST50H), 50ksi

**Coating:** G90

**ASTM:** A1003, ASTM A653

### INSTALLATION

#### Clip to Joist Attachment:

- The joist flange must rest on top of the Universal Joist Hanger as shown in the image to the right. Attach the UJH hanger with specified number of #10 or #14 screws as listed in the table below under the Joist column.

#### Clip attachment to CFS Header:

- Attach the UJH hanger to the top and side (face) of the CFS Header with specified number of #10 screws as listed in the table below.

#### Clip attachment to Structural/Steel Beam

- Welded Connection:**  
The minimum required weld to the top flange is 2" fillet weld to each side of top flange. Special considerations must be taken when welding galvanized steel.
- PAF (Powder Actuated Fasteners):**  
For powder actuated fasteners attachment (PAF, 0.157"), steel beam shall have minimum 3/16" thickness and minimum yield strength of 36ksi.

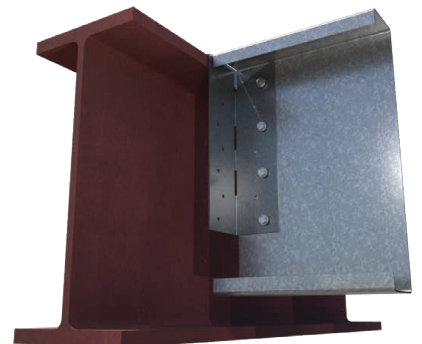
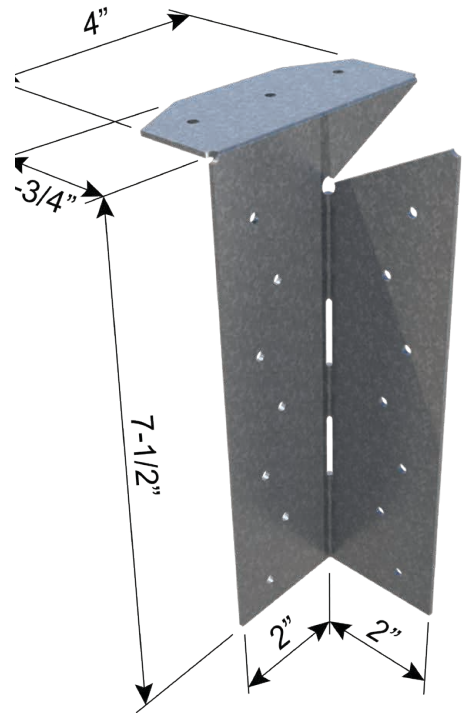

### Universal Joist Hanger (UJH)

Product code	Thickness		Packaging Pcs./Bucket
	Mils (Gauge)	Design thickness (in)	
UJH-68	68mils (14ga)	0.0713"	50
UJH-97	97mils (12ga)	0.1017"	50



**UJH-68 Mils (14ga)**

**ALLOWABLE HANGER LOADS**

Product code	Joist (Gauge)	Header (Gauge)	Fasteners			Allowable ASD Loads (lbs)	
			Top	Face	Joist	Uplift	Down
<b>ATTACHMENT TO CFS HEADER</b>							
UJH-68	18	16	2 - #10	2 - #10	2 - #10	430	473
			3 - #10	4 - #10	4 - #10	860	946
			3 - #10	7 - #10	7 - #10	860	1021
	16	16	2 - #10	2 - #10	2 - #10	789	789
			3 - #10	4 - #10	4 - #10	1548	1548
			3 - #10	7 - #10	7 - #10	1548	1705
	14	14	2 - #10	2 - #10	2 - #10	852	935
			3 - #10	4 - #10	4 - #10	1639	1798
			3 - #10	7 - #10	7 - #10	2077	2115
	12	12	2 - #10	2 - #10	2 - #10	906	1035
			3 - #10	4 - #10	4 - #10	1710	1953
			3 - #10	7 - #10	7 - #10	2536	3026

<b>ATTACHMENT TO STEEL HEADER</b>							
UJH-68	18	2" long fillet [Weld to each side of top flange]		2 - #10	132	788	
				4 - #10	263	975	
				7 - #10	298	975	
	16		2 - #10	132	997		
			4 - #10	263	1148		
			7 - #10	334	1148		
	14		2 - #10	132	997		
			4 - #10	263	1148		
			7 - #10	334	1148		
	12		2 - #10	132	1035		
			4 - #10	263	1285		
			7 - #10	334	1285		
	18			2 x 0.157" PAF	2 - #10	126	784
				3 x 0.157" PAF	4 - #10	136	869
				7 - #10	136	869	
	16			2 x 0.157" PAF	2 - #10	132	965
				3 x 0.157" PAF	4 - #10	171	1117
				7 - #10	171	1117	
	14			2 x 0.157" PAF	2 - #10	132	965
				3 x 0.157" PAF	4 - #10	171	1117
				7 - #10	171	1117	
	12			2 x 0.157" PAF	2 - #10	132	1035
				3 x 0.157" PAF	4 - #10	241	1279
				7 - #10	241	1304	

**Notes:**

- 1 Screws shall be installed through the pre-drilled holes in the hanger or as detailed by the designer.
- 2 CFS joist shall be laterally braced per designer specification.
- 3 For a gap between the end of the joist and the face of the hanger ranging between 0" - 1/2", no adjustment factor is required. When the gap is between 1/2" and 7/8", an adjustment factor of 0.95 shall be used to the load capacities listed.
- 4 For skew condition up to 45°, an adjustment factor of 0.95 for 7-screw condition and 0.80 for 4-screw condition shall be used. No skew is allowed for 2-screw connection.
- 5 If the clip is installed hard side (exterior web) of CFS joist, an adjustment factor of 0.95 shall be used to the load capacities listed. In addition, if the clip has to be skewed up to 45°, an additional adjustment factor of 0.95 for 7-screw condition and 0.80 for 4-screw condition shall be used to the load capacities listed.
- 6 CFS header must be braced to prevent web crippling/buckling per designer specification.
- 7 CFS header must provide full bearing of 1-5/8" flange-depth.
- 8 Backing of the steel beam cavity is not required behind the hanger for the load listed.
- 9 The ultimate screw shear strength for #10 screws shall be at least 1644 lbs.
- 10 The screw shear strength capacities are based on CFSEI Tech Note (F701-12).
- 11 Allowable loads have not been increased for seismic or wind.
- 12 Contact ClarkDietrich Engineering Services for technical assistance.

## Universal Joist Hanger

### UJH-97 Mils (12ga)

### ALLOWABLE HANGER LOADS

Product code	Joist (Ga)	Header (Ga)	Fasteners			Allowable ASD Loads (lbs)	
			Top	Face	Joist	Uplift	Down
<b>ATTACHMENT TO CFS HEADER</b>							
UJH-97	18	16	2 - #10	2 - #10	2 - #14	439	489
			3 - #10	4 - #10	4 - #14	860	959
			3 - #10	7 - #14	7 - #14	958	1021
	16	16	2 - #10	2 - #10	2 - #14	940	940
			3 - #10	4 - #10	4 - #14	1773	1773
			3 - #10	7 - #14	7 - #14	1773	1931
	14	14	2 - #10	2 - #10	2 - #14	1123	1327
			3 - #10	4 - #10	4 - #14	2041	2413
			3 - #10	7 - #14	7 - #14	2388	2445
	12	12	2 - #10	2 - #10	2 - #14	1238	1898
			3 - #10	4 - #10	4 - #14	2135	3273
			3 - #10	7 - #14	7 - #14	4092	4350

<b>ATTACHMENT TO STEEL HEADER</b>							
UJH-97	18	2" long fillet [Weld to each side of top flange]		2 - #14	201	837	
				4 - #14	401	975	
				7 - #14	431	975	
	16			2 - #14	201	1472	
				4 - #14	401	1570	
				7 - #14	577	1696	
	14			2 - #14	201	1472	
				4 - #14	401	1570	
				7 - #14	577	1696	
	12			2 - #14	201	1651	
				4 - #14	401	1738	
				7 - #14	598	1761	
	18			2 x 0.157" PAF	2 - #14	201	890
				3 x 0.157" PAF	4 - #14	252	890
					7 - #14	252	890
	16			2 x 0.157" PAF	2 - #14	201	1380
				3 x 0.157" PAF	4 - #14	332	1626
					7 - #14	332	1626
	14			2 x 0.157" PAF	2 - #14	201	1380
				3 x 0.157" PAF	4 - #14	332	1626
					7 - #14	332	1626
	12			2 x 0.157" PAF	2 - #14	201	1644
				3 x 0.157" PAF	4 - #14	367	1730
					7 - #14	367	1812

**Notes:**

- 1 Screws shall be installed through the pre-drilled holes in the hanger or as detailed by the designer.
- 2 CFS joist shall be laterally braced per designer specification.
- 3 For a gap between the end of the joist and the face of the hanger ranging between 0" - 7/8", no adjustment factor is required.
- 4 For skew condition up to 45°, an adjustment factor of 0.85 for 7-screw condition and 0.90 for 4-screw condition shall be used. No skew is allowed for 2-screw connection.
- 5 If the clip is installed hard side (exterior web) of CFS joist, no adjustment factor is required.
- 6 CFS header must be braced to prevent web crippling/buckling per designer specification.
- 7 CFS header must provide full bearing of 1-5/8" flange-depth.
- 8 Backing of the steel beam cavity is not required behind the hanger for the load listed.
- 9 The ultimate screw shear strength for #14 screws shall be at least 3048 lbs.
- 10 The screw shear strength capacities are based on CFSEI Tech Note (F701-12).
- 11 Allowable loads have not been increased for seismic or wind.
- 12 Contact ClarkDietrich Engineering Services for technical assistance.



## Skewable Angle

For rigid and off-angle attachments of joist-to-joist, joist-to-hip beam, or to other structural steel members.

ClarkDietrich skewable angles are used to make rigid attachments of joist-to-joist or joist-to-other miscellaneous framing. This clip is ideal for making off-angle attachments. It is easily field bent from 0° to 90°.

**CAUTION:** This clip can only be bent one time.

### PRODUCT DIMENSIONS

**Legs:** 2" x 2"

**Clip Lengths:** 3", 4-3/8", 5", 6-3/8", 7", 9"

### MATERIAL SPECIFICATIONS

**Gauge:** 18 gauge (43mils)

**Design Thickness:** 0.0451 inches

**Coating:** G90

**ASTM:** A653/A1003

### INSTALLATION

Use specified fasteners. For off-angle connections, field bend (ONE TIME ONLY) to the required degree so the Skewable Angle fits securely over the two adjoining members. Secure the Skewable Angle by filling all prepunched screw holes with #10 screws or as required by design. Joist must be constrained against rotation when using a single Skewable Angle per connection.

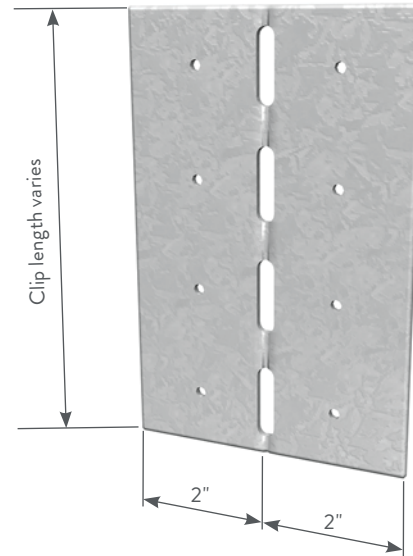

## Skewable Angles (SA)

Product code	Product Thickness		Height (in)	Packaging Pcs./Carton
	Mils (Gauge)	Design thickness (in)		
SA3	43mils (18ga)	0.0451	3	100
SA4	43mils (18ga)	0.0451	4-3/8	100
SA5	43mils (18ga)	0.0451	5	100
SA6	43mils (18ga)	0.0451	6-3/8	100
SA7	43mils (18ga)	0.0451	7	100
SA9	43mils (18ga)	0.0451	9	100

### Skewable Angle Allowable Loads

Product code	Stud thickness Mils (Gauge)	Length (in)	Fasteners	Allowable Loads (lbs)	
				Shear (F1)	Tension (F2)
SA3	33mils (20ga)	3.000	6 - #10	339	251
	43mils (18ga)			372	328
	54mils (16ga)			372	594
	68mils (14ga)			372	677
	97mils (12ga)			372	677
SA4	33mils (20ga)	4.375	6 - #10	339	251
	43mils (18ga)			505	328
	54mils (16ga)			512	594
	68mils (14ga)			512	748
	97mils (12ga)			512	930
SA5	33mils (20ga)	5.000	8 - #10	510	335
	43mils (18ga)			744	437
	54mils (16ga)			744	792
	68mils (14ga)			744	998
	97mils (12ga)			744	1353
SA6	33mils (20ga)	6.375	10 - #10	690	419
	43mils (18ga)			884	546
	54mils (16ga)			884	990
	68mils (14ga)			884	1247
	97mils (12ga)			884	1607
SA7	33mils (20ga)	7.000	10 - #10	690	419
	43mils (18ga)			1027	546
	54mils (16ga)			1116	990
	68mils (14ga)			1116	1247
	97mils (12ga)			1116	1779
SA9	33mils (20ga)	9.000	14 - #10	1061	587
	43mils (18ga)			1116	765
	54mils (16ga)			1116	1386
	68mils (14ga)			1116	1746
	97mils (12ga)			1116	2030

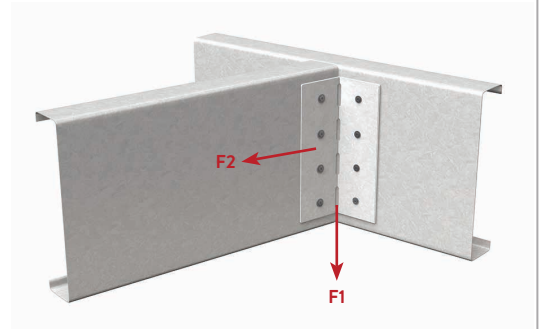

**Notes:**

- 1 Screws shall be attached through the pre-drilled holes provided.
- 2 The allowable values for F1 and F2 are to be used only when the clip leg is attached to cold-formed steel framing. The capacity of the attachment to other materials and structures must be checked separately.
- 3 This table is intended for use by a qualified design professional. It is the responsibility of the engineer to verify that the tabulated values apply to a specific connection application. The 1/8-in deflection service load limit is not included in the listed tension (F2) capacities.
- 4 Values for 18ga (43 mils) skewable angles were based on using 33 ksi calculations for worst case. These angles are manufactured using 50 ksi.
- 5 The ultimate screw shear strength and tensile strength for #10 screws should be at least 1644 lbs and 1158 lbs respectively. These shear and tensile capacities of #10 screws are based on CFSEI Tech Note (F701-12).
- 6 Allowable loads have not been increased for seismic or wind.
- 7 Contact ClarkDietrich Engineering Services for technical assistance.

**Typical Construction Details**

Visit our [CAD Library at itools.clarkdietrich.com](http://itools.clarkdietrich.com) to view or download construction details in .dwg, .dxf, and .pdf formats.

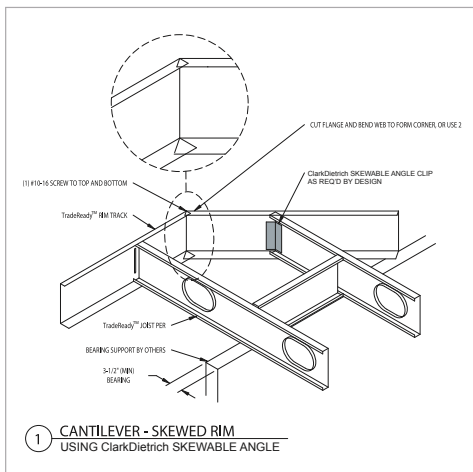

## Field Skewable TradeReady® Rim Track Splice Plate

Ideal for splicing rim joist and is easily field skewable for off-angle rim joist connections.

The ClarkDietrich field skewable TradeReady® rim track splice plate provides an easy and efficient method for splicing TradeReady rim. This prepunched plate is also ideal for connecting and reinforcing the rim at bay or bow window details. The center of the plate allows for easy one-time field bending from 0° to 135°.

**CAUTION:** This plate can only be bent one time.

### MATERIAL SPECIFICATIONS

**Gauge:** 16 gauge (54mils)

**Design Thickness:** 0.0566 inches

**Yield Strength:** 50ksi

**Coating:** G90

**ASTM:** A653/A653M

### INSTALLATION

For splicing connections, align center slots in splice plate over the joint of the rim joists. Secure splice plate by filling all prepunched screw holes with #10 screws.

For off-angle connections, field bend (ONE TIME ONLY) to the required degree so the plate fits securely over the two adjoining members. Secure field skewable plate by filling all prepunched screw holes with #10 screws.

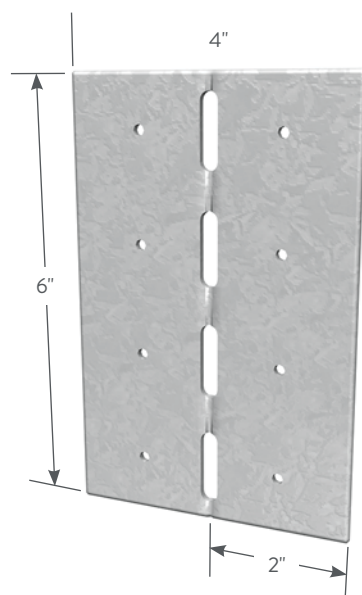

Field Skewable TradeReady Rim Track Splice Plate

### Field Skewable TradeReady® Rim Track Splice Plates (TDSP)

Product code	Thickness		Size (in)	Packaging Pcs./Bucket
	Mils (Gauge)	Design thickness (in)		
TDSP	54mils (16ga)	0.0566	4 x 6	100

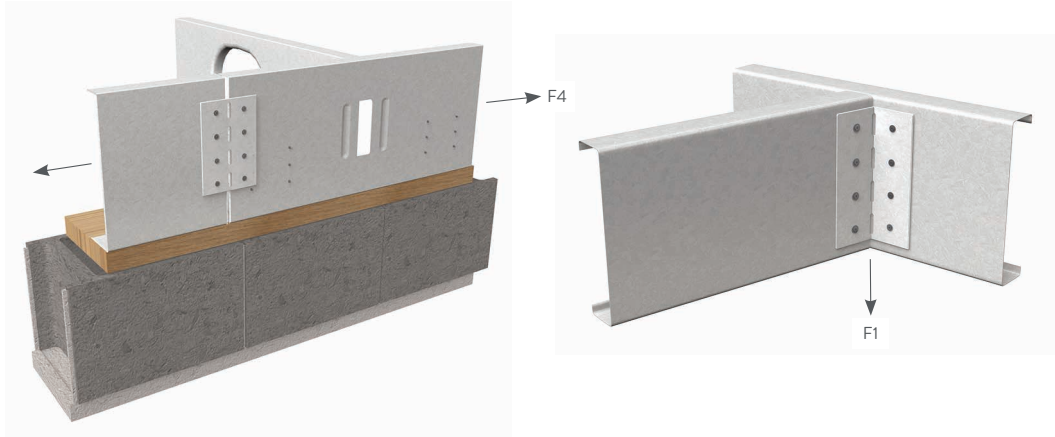

### Field Skewable TradeReady® Rim Track Splice Plates (TDSP)

### ALLOWABLE LOADS

Product code	TDSP gauge	Framing material gauge	Framing material yield (ksi)	Tension F4 (lbs)	Shear F1 (lbs)
TDSP	18	20	33	560	437
		18 or thicker	33	832	650
TDSP	16	20	33	560	437
		18	33	832	650
		16 or thicker	33	1172	915
			50	1680	1312

**Notes:**

- 1 Screws shall be attached in the pre-drilled holes provided.
- 2 The allowable values for F1 and F4 are to be used only when the clip leg is attached to the CFS framing. The screw pattern must be as shown above. The capacity of the attachment to other materials and structures must be checked separately.
- 3 This table is intended for use by qualified engineers only. It is the responsibility of the engineer to verify that the tabulated values apply to a specific connection application.
- 4 The screw diameter must be 0.19" (min.) for #10 screws.
- 5 The ultimate screw shear strength must be a minimum of 1400 lbs for #10 screws.
- 6 Screws must be long enough so that at least three exposed threads are visible after installation.
- 7 Allowable loads have not been increased 33% for wind or seismic.
- 8 For connections made to 14 gauge (68mils), and 12 gauge (97mils), use the tabulated values for 16 gauge (54mils), 50ksi, when using TDSP (16 gauge). Similarly when TDSP (18 gauge) is used with thicker base materials, the values for 18 gauge x 33ksi are to be used.
- 9 It is the responsibility of the design professional to detail the drawings for proper clip attachment.
- 10 Contact ClarkDietrich at 888-437-3244 for technical assistance.

### TYPICAL CONSTRUCTION DETAILS

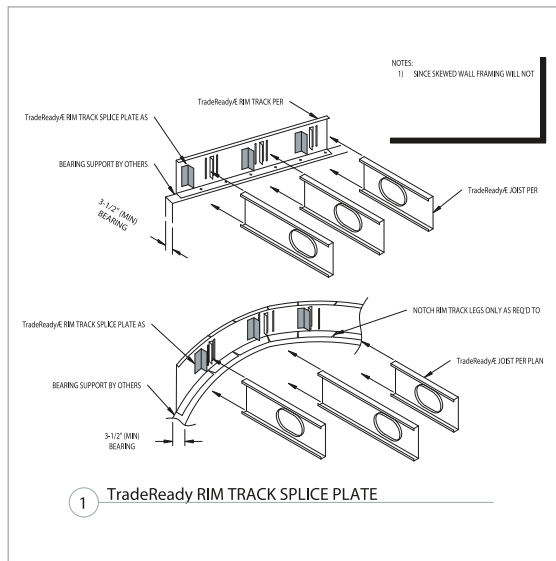
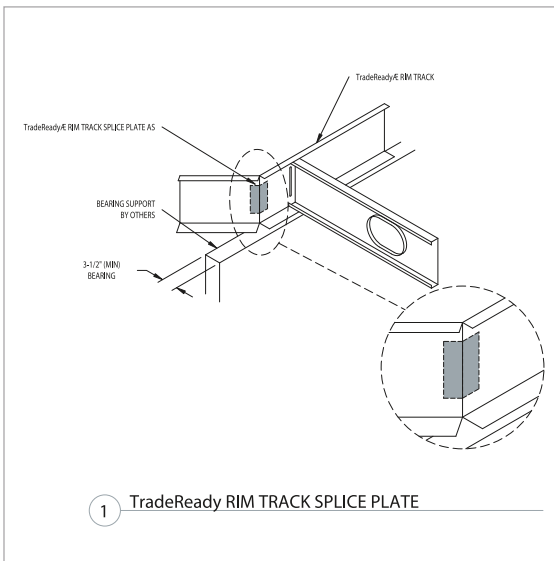

Visit our CAD Library at [clarkdietrich.com](http://clarkdietrich.com) to view or download construction details in .dwg, .dxf, and .pdf formats.

## TradeReady® Floor Joist Blocking

Quick and efficient system that prevents joist rotation and accommodates mechanical passing

TradeReady Floor Joist Blocking is one of the primary components that make up the TradeReady floor bracing system. TradeReady Blocking features a large extruded hole to accommodate HVAC, mechanical, plumbing and sprinkler runs.

TradeReady Blocking is pre-cut and formed to fit securely between the floor joists to prevent joist rotation. Designed to be used with joist up to 3" legs. Pre-punched holes in the connection legs are added for quick attachment to each floor joist. Structural blocking is an economical alternative to Tension Bracing (CDTB) or Diagonal Tension Strapping.

Floor Joist Blocking is typically used in conjunction with a continuous row of TradeReady Structural Bridging (TDSB) that ties the floor system to the structure allowing bracing against lateral movement.

### ALTERNATIVE PRODUCTS

- Tension Bracing
- Diagonal Tension Strapping

### MATERIAL SPECIFICATIONS

- Gauge: 16 gauge (54mils)
- Design Thickness: 0.0566 inches
- Coating: G90
- ASTM: A1003

### INSTALLATION

Place the notched end of the TradeReady Blocking inside the open side of one floor joist. Attached each end of the TradeReady Blocking to each floor joist with (2) #10-16 screws in pre-punched holes.

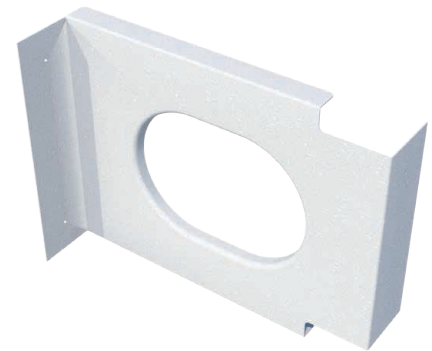
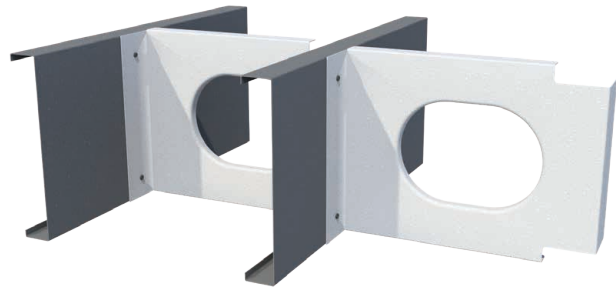

### Floor Joist Blocking (JB)

Product code	Thickness		Joist Size (in)	Hole Size (in)	Packaging Pcs./Ctn						
	Mils (Gauge)	Design thickness (in)									
725JB12	54mils (16ga)	0.0566	7-1/4	4-1/2" x 7"	10						
800JB12			8	4-1/2" x 7"							
925JB12			9-1/4	6-1/2" x 9"							
1000JB12			10	6-1/2" x 9"							
1125JB12			11-1/4	6-1/2" x 9"							
1200JB12			12	6-1/2" x 9"							
1400JB12			14	6-1/2" x 9"							
725JB16			54mils (16ga)	0.0566		7-1/4	4-1/2" x 7"	10			
800JB16						8	4-1/2" x 7"				
925JB16						9-1/4	6-1/2" x 9"				
1000JB16						10	6-1/2" x 9"				
1125JB16						11-1/4	6-1/2" x 9"				
1200JB16						12	6-1/2" x 9"				
1400JB16						14	6-1/2" x 9"				
725JB24						54mils (16ga)	0.0566		7-1/4	4-1/2" x 7"	10
800JB24									8	4-1/2" x 7"	
925JB24									9-1/4	6-1/2" x 9"	
1000JB24									10	6-1/2" x 9"	
1125JB24									11-1/4	6-1/2" x 9"	
1200JB24									12	6-1/2" x 9"	
1400JB24									14	6-1/2" x 9"	



## TradeReady® Structural Bridging

Pre-cut structural blocking that installs easily to the underside of the joists to prevent joist rotation.

TradeReady® structural bridging is the third component of the TradeReady steel floor system. Pre-punched for quick attachment, structural blocking is pre-cut to fit securely between the underside of the floor joists to prevent joist rotation. Structural blocking is an economical alternative to cross bracing, X-bracing or strapping.

**CAUTION:** In order to prevent joist rolling, the TDSB blocking must be tied into the structure or otherwise braced against lateral movement.

**NOTE:** TDSB blocking is not required if sheathing is applied to the joists top and bottom.

### PRODUCT DIMENSIONS

- 2-1/2" x 12"
- 2-1/2" x 16"
- 2-1/2" x 19.2"
- 2-1/2" x 24"

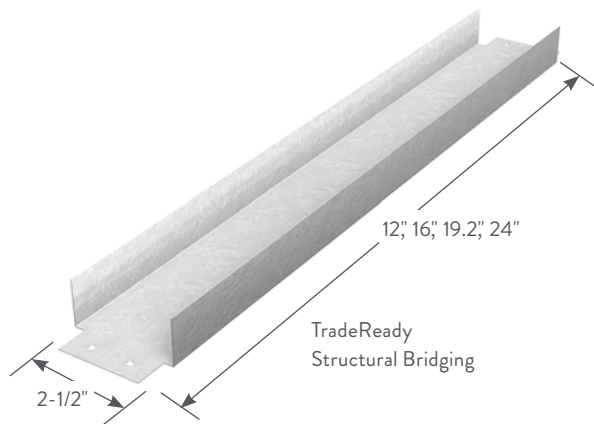

### MATERIAL SPECIFICATIONS

- Gauge:** 18 gauge (43mils)
- Design Thickness:** 0.0451 inches
- Coating:** CP60
- ASTM:** A653/A653M, C955

### INSTALLATION

A continuous row of TradeReady structural blocking should be installed every 8' o.c. maximum and staggered for easy attachment. Blocking is secured to each joist flange using two #10 screws at each end.



### TradeReady® Structural Bridging (TDSB)

Product code	Thickness		Size (in)	Packaging Pes./Bundle
	Mils (Gauge)	Design thickness (in)		
TDSB12	43mils (18ga)	0.0451	2-1/2 x 12	10
TDSB16	43mils (18ga)	0.0451	2-1/2 x 16	10
TDSB19	43mils (18ga)	0.0451	2-1/2 x 19.2	10
TDSB24	43mils (18ga)	0.0451	2-1/2 x 24	10

## EasyClip™ QuickTwist™ Web Stiffener

Excellent reinforcement at critical load points to prevent web crippling.

ClarkDietrich EasyClip™ QuickTwist™ web stiffeners are used to provide reinforcement of joist webs to prevent crippling. Web reinforcement is often required by design to enhance the load capacity of joists. The unique design of QTWS allows the installer to easily insert the stiffener on the inside of the joist *after* the joist is installed. This stiffener eliminates the need to pre-insert traditional web stiffeners prior to joist installation. The one-piece assembly is easily rotated in-place for a tight fit.

### PRODUCT DIMENSIONS

3-1/2" x 6"-14" x 1-1/4"  
 6" x 6"-14" x 1-1/4"

### MATERIAL SPECIFICATIONS

**Gauge:** 12 gauge (97mils)  
**Design Thickness:** 0.1017 inches  
**Coating:** G90  
**Yield Strength:** 50ksi  
**ASTM:** A653/A653M

### INSTALLATION

The unique design of the EasyClip QuickTwist web stiffener allows it to be easily rotated in-place for a tight fit between flanges. The web stiffener shall be secured to the web of the joist with (3) #10-16 screws. Screws shall be driven through the top, bottom and middle prepunched holes as shown in the illustrations.

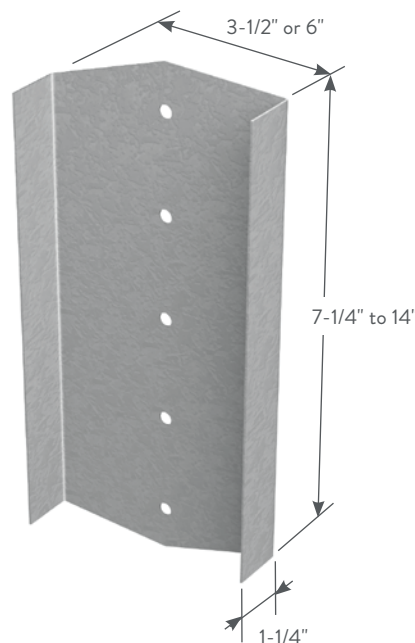

## EasyClip™ QuickTwist™ Web Stiffeners (QTWS)

Product code	Size (in) width	Thickness		Size* (in) length	Packaging
		Mils (Gauge)	Design thickness (in)		
QTWS	3-1/2	97mils (12ga)	0.1017	6	Dependent on order quantity
				7-1/4	
				8	
				9-1/4	
				10	
				11-1/4	
				12	
				14	
QTWS	6	97mils (12ga)	0.1017	6	Dependent on order quantity
				7-1/4	
				8	
				9-1/4	
				10	
				11-1/4	
				12	
				14	

\*Dimension is nominal size. Actual product is shorter to fit inside joist.

Note: The QTWS is designed to work with all floor joist flanges but the length of the QTWS clip shall match the depth of the supporting floor joist.

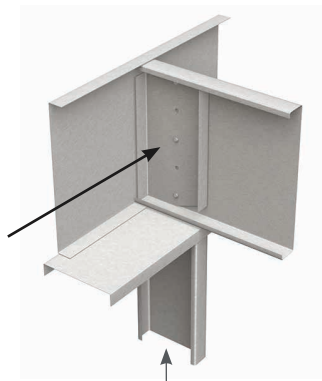
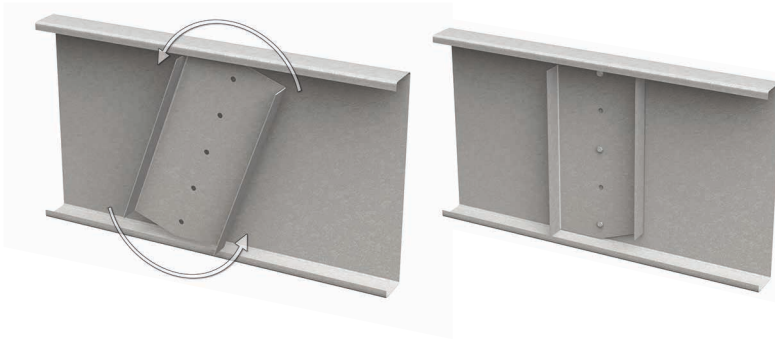

**CONDITION 1**  
(3) #10-16 screws,  
top, bottom, and  
middle holes

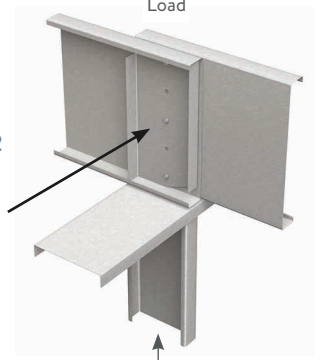

**CONDITION 2**  
(3) #10-16 screws,  
top, bottom, and  
middle holes

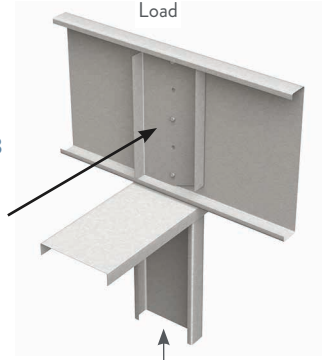

**CONDITION 3**  
(3) #10-16 screws,  
top, bottom, and  
middle holes

**QTWS Allowable Web Crippling Loads (lbs)**

Joist size (in)	Joist Mils (gauge)	F <sub>y</sub> (ksi)	3-1/2" Web Stiffener			6" Web Stiffener		
			Cond. 1	Cond. 2	Cond. 3	Cond. 1	Cond. 2	Cond. 3
7.25	43 (18)	33	5,360	5,781	5,659	5,932	6,403	6,265
		33	5,457	6,155	5,924	6,042	6,817	6,558
	54 (16)	50	5,574	6,632	6,282	6,177	7,351	6,959
		33	5,615	6,761	6,346	6,220	7,482	7,021
	68 (14)	50	5,813	7,550	6,921	6,447	8,359	7,660
		33	6,074	8,524	7,559	6,733	9,401	8,340
97 (12)	50	6,509	10,222	8,759	7,224	11,267	9,659	
	33	5,350	5,752	5,645	5,920	6,370	6,249	
8	43 (18)	33	5,443	6,116	5,905	6,027	6,773	6,537
		50	5,553	6,573	6,253	6,153	7,285	6,926
	54 (16)	33	5,596	6,708	6,320	6,200	7,424	6,992
		50	5,786	7,470	6,882	6,416	8,270	7,617
	68 (14)	33	6,045	8,438	7,516	6,700	9,307	8,293
		50	6,465	10,092	8,694	7,174	11,124	9,588
9.25	43 (18)	33	5,334	5,707	5,623	5,902	6,320	6,224
		33	5,422	6,056	5,875	6,002	6,706	6,503
	54 (16)	50	5,521	6,481	6,208	6,116	7,182	6,876
		33	5,568	6,626	6,279	6,167	7,332	6,947
	68 (14)	50	5,742	7,345	6,820	6,366	8,132	7,548
		33	5,999	8,304	7,450	6,649	9,159	8,220
97 (12)	50	6,396	9,888	8,594	7,096	10,900	9,477	
	33	5,410	6,021	5,858	5,988	6,667	6,484	
10	54 (16)	50	5,503	6,429	6,182	6,095	7,124	6,847
		33	5,552	6,579	6,256	6,148	7,280	6,922
	68 (14)	50	5,718	7,275	6,785	6,338	8,053	7,510
		33	5,973	8,228	7,412	6,619	9,076	8,179
	97 (12)	50	6,356	9,773	8,537	7,052	10,773	9,415
		33	5,391	5,967	5,831	5,966	6,606	6,454
11.25	54 (16)	50	5,474	6,347	6,141	6,062	7,032	6,802
		33	5,526	6,505	6,220	6,119	7,198	6,881
	68 (14)	50	5,679	7,163	6,730	6,294	7,929	7,448
		33	5,932	8,108	7,353	6,573	8,943	8,114
	97 (12)	50	6,294	9,590	8,447	6,981	10,573	9,316
		33	5,380	5,936	5,816	5,954	6,571	6,437
12	54 (16)	50	5,457	6,300	6,118	6,043	6,979	6,775
		33	5,511	6,463	6,199	6,102	7,151	6,858
	68 (14)	50	5,657	7,099	6,699	6,268	7,858	7,413
		33	5,908	8,039	7,319	6,547	8,867	8,076
	97 (12)	50	6,258	9,486	8,395	6,941	10,458	9,259
		33	5,474	6,356	6,146	6,060	7,033	6,800
14	68 (14)	50	5,601	6,937	6,619	6,204	7,678	7,325
		33	5,849	7,865	7,233	6,480	8,677	7,982
	97 (12)	50	6,169	9,223	8,265	6,840	10,169	9,116

**Notes:**

- 1 The tabulated values indicate the total allowable web crippling capacities of a ClarkDietrich joist of the listed size, stiffened with the QuickTwist web stiffener.
- 2 The joist flanges must be fastened to the support at the bearing location.
- 3 The 3-1/2" web stiffeners are to be used with bearing widths of 3-1/2" to 5-1/2" in the direction of the joist. The 6" web stiffeners are to be used with bearing widths 6" and greater, in the direction of the joist. A minimum-bearing dimension of 3" in the direction perpendicular to the joist is assumed.
- 4 Use (3) #10 screws to attach the QuickTwist web stiffener to the joist. Drive screws through the top, bottom, and middle prepunched holes.
- 5 This table is intended for use by qualified engineers only. It is the responsibility of the engineer to verify that the QuickTwist web stiffener configuration and tabulated values apply to a specific web crippling application.
- 6 Contact ClarkDietrich at 888-437-3244 for technical assistance.

## EasyClip™ E-Series™ Support Clip

Long leg accommodates greater standoff for rigid connections.

ClarkDietrich EasyClip™ E-Series™ support clips are primarily used for rigid standoff connections. The 4" wide leg provides extra length to achieve standoff connections up to 3". The EasyClip E-Series support clips are also commonly used in bypass wall conditions, a variety of floor framing applications including solid and ladder blocking attachments and joist-to-joist connections, and to secure rafter framing to the primary structure. Available in a variety of lengths and gauges, these clips are prepunched for faster and more accurate fastener placement.

### ALTERNATIVE PRODUCTS

Uni-Clip™

EasyClip™ D-Series™ Anchor Clip

EasyClip T-Series™ Tall Anchor Clip

SwiftClip™ LE-Series™ Support Clip

### PRODUCT DIMENSIONS

1-1/2" x 4" x 3"

1-1/2" x 4" x 5"

1-1/2" x 4" x 7"

1-1/2" x 4" x 9"

1-1/2" x 4" x 11"

### MATERIAL SPECIFICATIONS

**Gauge:** 16 gauge (54mils)

**Design Thickness:** 0.0566 inches

**Gauge:** 14 gauge (68mils)

**Design Thickness:** 0.0713 inches

**Gauge:** 12 gauge (97mils)

**Design Thickness:** 0.1017 inches

**Coating:** G90

**Yield Strength:** 50ksi

**ASTM:** A653/A653M

### INSTALLATION

EasyClip E-Series support clips are attached to the cold-formed steel (CFS) framing members using #10 minimum self-drilling screws driven through the clip holes into the steel framing. When not filling all holes, install fasteners symmetrically starting at the top and bottom edges and move toward the center of the clip. Clip can also be welded to the CFS framing. Connections to the building frame can be made with powder-actuated fasteners, drill-in concrete anchors or welding. When using the tabular values for a welded clip, provide a full weld to the structure, top to bottom, along the outside edge of the clip. A 3/4" minimum weld on the outside edge of the 1-1/2" leg is also required to control warping or to hold the clip in place before final welding.

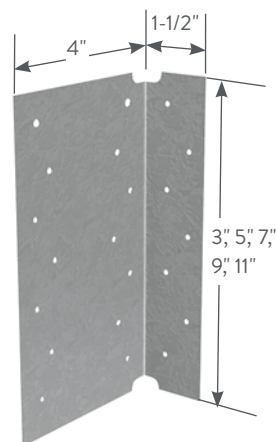

EasyClip E-Series  
Support Clip

### EasyClip™ E-Series™ Support Clips

Product code	Thickness		Size (in)	Packaging Pcs./Bucket
	Mils (Gauge)	Design thickness (in)		
E543	54mils (16ga)	0.0566	4 x 1-1/2 x 3	100
E545	54mils (16ga)	0.0566	4 x 1-1/2 x 5	100
E547	54mils (16ga)	0.0566	4 x 1-1/2 x 7	100
E549	54mils (16ga)	0.0566	4 x 1-1/2 x 9	50
E541	54mils (16ga)	0.0566	4 x 1-1/2 x 11	50
E683	68mils (14ga)	0.0713	4 x 1-1/2 x 3	100
E685	68mils (14ga)	0.0713	4 x 1-1/2 x 5	100
E687	68mils (14ga)	0.0713	4 x 1-1/2 x 7	80
E689	68mils (14ga)	0.0713	4 x 1-1/2 x 9	50
E681	68mils (14ga)	0.0713	4 x 1-1/2 x 11	50
E973	97mils (12ga)	0.1017	4 x 1-1/2 x 3	50
E975	97mils (12ga)	0.1017	4 x 1-1/2 x 5	50
E977	97mils (12ga)	0.1017	4 x 1-1/2 x 7	50
E979	97mils (12ga)	0.1017	4 x 1-1/2 x 9	50
E971	97mils (12ga)	0.1017	4 x 1-1/2 x 11	40

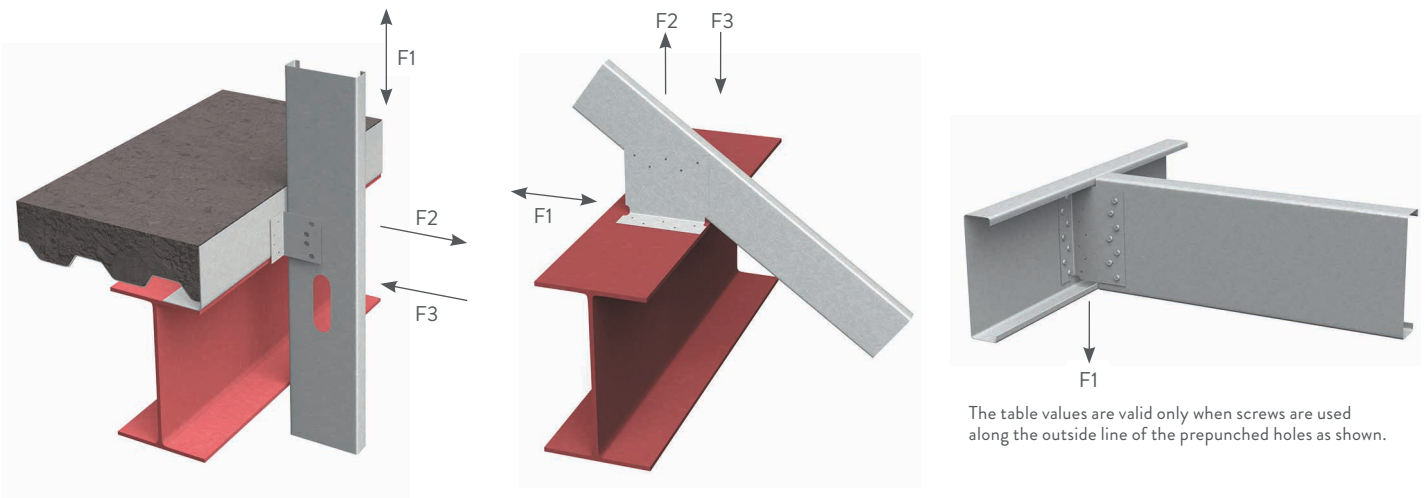

The table values are valid only when screws are used along the outside line of the prepunched holes as shown.

**E-Series™ Support Clips Allowable Clip Capacities (lbs)**

**USING #10-16 SELF-DRILLING SCREWS**

Product code	No. of screws to steel framing	Stud Thickness and Yield Strength								
		20ga (33mils) 33ksi			18ga (43mils) 33ksi			16ga (54mils) 50ksi		
		F1	F2	F3	F1	F2	F3	F1	F2	F3
E543	3	101 (101)	210 (531)	507	150 (150)	210 (788)	507	266 (155)	210 (1195)	507
E545	2	176 (176)	354 (354)	354	261 (261)	371 (525)	525	463 (453)	371 (933)	811
	5	251 (251)	371 (885)	885	372 (372)	371 (1313)	912	625 (479)	371 (2105)	912
E547	4	380 (380)	531 (708)	708	564 (564)	531 (1050)	1050	1002 (970)	531 (1867)	1347
	7	455 (455)	531 (1239)	1239	675 (675)	531 (1838)	1318	1169 (960)	531 (3015)	1318
E549	4	477 (477)	692 (708)	708	707 (707)	692 (1050)	1050	1257 (1257)	692 (1867)	1753
	9	706 (706)	692 (1593)	1593	1048 (1048)	692 (2363)	1724	1862 (1576)	692 (3925)	1724
E541	6	727 (727)	852 (1062)	1062	1079 (1079)	852 (1576)	1576	1918 (1918)	852 (2800)	2053
	11	995 (995)	852 (1947)	1947	1476 (1476)	852 (2889)	2130	2623 (2301)	852 (4835)	2130
E683	3	101 (101)	333 (531)	531	150 (150)	333 (788)	788	266 (196)	333 (1400)	1011
E685	2	176 (176)	354 (354)	354	261 (261)	525 (525)	525	463 (463)	587 (933)	933
	5	251 (251)	587 (885)	885	372 (372)	587 (1313)	1313	661 (602)	587 (2333)	1817
E687	4	380 (380)	708 (708)	708	564 (564)	841 (1050)	1050	1002 (1002)	841 (1867)	1867
	7	455 (455)	841 (1239)	1239	675 (675)	841 (1838)	1838	1200 (1200)	841 (3267)	2625
E689	4	477 (477)	708 (708)	708	707 (707)	1050 (1050)	1050	1257 (1257)	1095 (1867)	1867
	9	706 (706)	1095 (1593)	1593	1048 (1048)	1095 (2363)	2363	1862 (1862)	1095 (4200)	3434
E681	6	727 (727)	1062 (1062)	1062	1079 (1079)	1349 (1576)	1576	1918 (1918)	1349 (2800)	2800
	11	995 (995)	1349 (1947)	1947	1476 (1476)	1349 (2889)	2889	2623 (2623)	1349 (5133)	4244
E973	3	101 (101)	531 (531)	531	150 (150)	679 (788)	788	266 (266)	679 (1400)	1400
E975	2	176 (176)	354 (354)	354	261 (261)	525 (525)	525	463 (463)	933 (933)	933
	5	251 (251)	885 (885)	885	372 (372)	1196 (1313)	1313	661 (661)	1196 (2333)	2333
E977	4	380 (380)	708 (708)	708	564 (564)	1050 (1050)	1050	1002 (1002)	1713 (1867)	1867
	7	455 (455)	1239 (1239)	1239	675 (675)	1713 (1838)	1838	1200 (1200)	1713 (3267)	3267
E979	4	477 (477)	708 (708)	708	707 (707)	1050 (1050)	1050	1257 (1257)	1867 (1867)	1867
	9	706 (706)	1593 (1593)	1593	1048 (1048)	2229 (2363)	2363	1862 (1862)	2229 (4200)	4200
E971	6	727 (727)	1062 (1062)	1062	1079 (1079)	1576 (1576)	1576	1918 (1918)	2746 (2800)	2800
	11	995 (995)	1947 (1947)	1947	1476 (1476)	2746 (2889)	2889	2623 (2623)	2746 (5133)	5133

**Notes:**

**Screw Capacity Notes:**

- The tabulated value indicates the number of screws in a single clip leg attached to the cold-formed steel (CFS) framing.
- Screws shall be attached in a symmetric manner, starting at the outside holes. See screw options on opposite page and above for examples.
- The allowable values for F1 are based only on the shear capacity of the 4" clip leg attached to the CFS framing. The capacity of the attachment to other materials and structures must be checked separately.
- The allowable values for F2 assume mechanical fasteners are attached to the structure using the 1-1/2" leg, and are along the vertical centerline of the clip leg. Mechanical fasteners to other materials and structures must be checked separately.
- This table is intended for use by qualified engineers only. It is the responsibility of the engineer to verify that the tabulated values apply to a specific connection application.
- When clips have combinations of F1, F2, and F3, use a linear interaction for combinations of F1 and F3, and a squared interaction for combinations of F1 and F2.
- The screw diameter must be 0.19" (min) for #10 screws.
- The ultimate screw shear strength must be a minimum of 1400 lbs for #10 screws.

- Screws must be long enough so at least three exposed threads are visible after installation.
- Allowable loads have not been increased 33% for wind or seismic.
- For connections made to 14ga (68mils) and 12ga (97mils), use the tabulated values for 16ga (54mils), 50ksi.
- Contact ClarkDietrich Technical Services at 888-437-3244 for assistance.

**Weld Capacity Notes:**

- F1 and F2 values in parentheses are maximum shear and tension capacities when the clips are welded to the base structure (min 3/16" — 36ksi).
- Listed weld capacities are computed assuming an E70XX welding rod or wire.
- The clips are to be welded to the structure along the back corner along the complete length of the clip. When secondary welds are used to hold the clip in place, they are not used in capacity calculations.

Product Detail

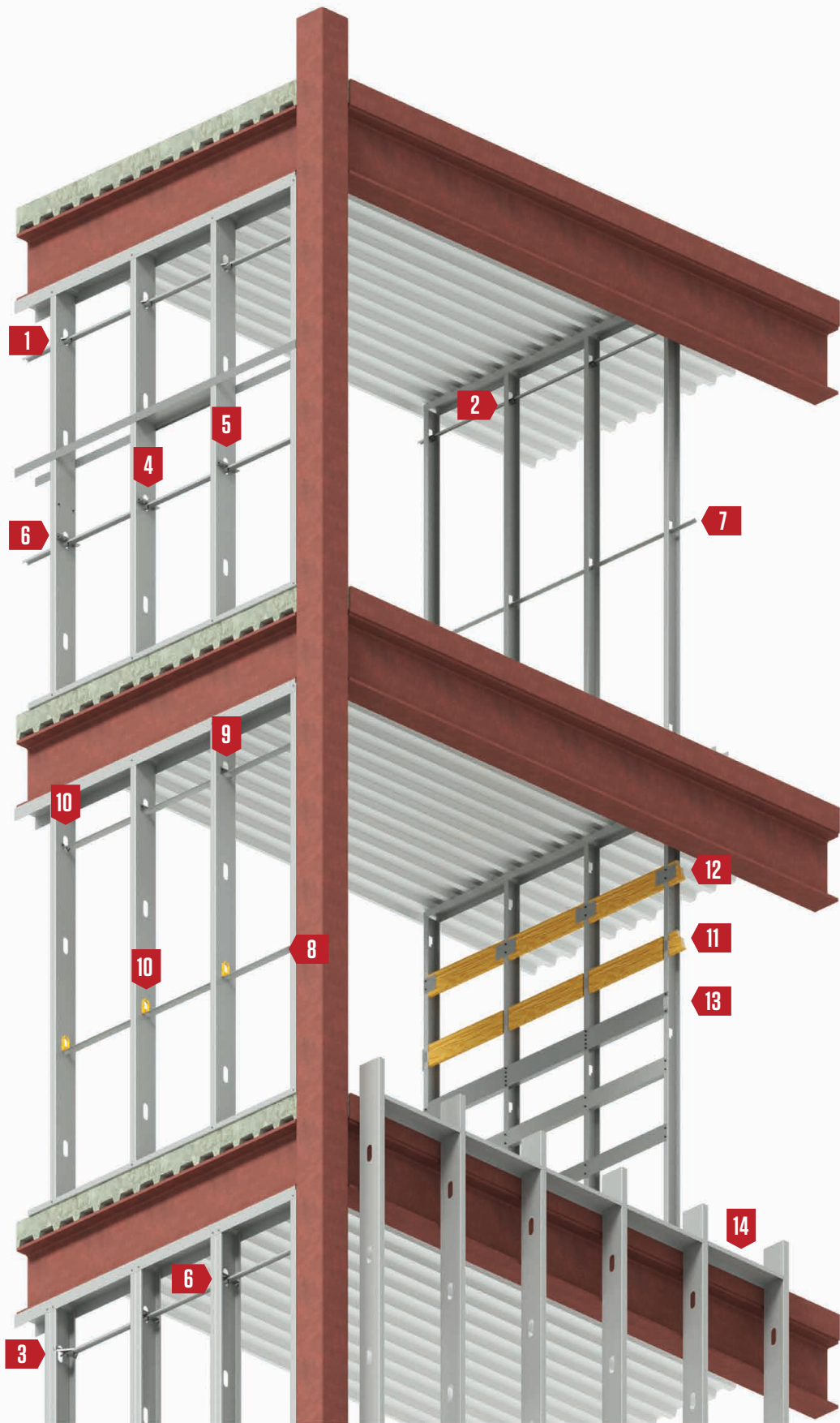

**1** FastBridge™ Clip  
pages 140-141

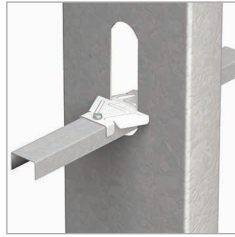

**2** CC33 3/4" Channel Clip  
page 142-143



**3** Bridging Termination Clip  
page 144-145



**4** EasyClip X-Series™ Clip Angle  
pages 146-147



**5** EasyClip™ U-Series™ Clip Angle  
page 89

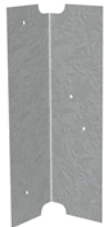

**6** SwiftClip™ L-Series™ Support Clip  
pages 86-87

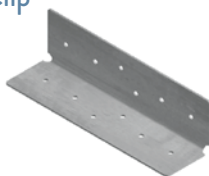

**7** Spazzer® 9200 Spacer Bar  
page 148



**8** Spazzer® 5400 Spacer Bar  
page 149-153



**9** Spazzer® Bar Fly Clip  
page 154

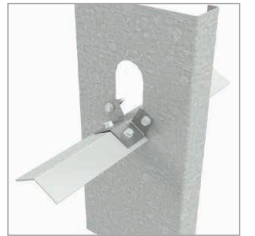

**10** Spazzer® Bar Guard and Snap-in Grommet  
page 149



**11** FastBack™ Backing System  
page 155



**12** Danback® Flexible Wood Backing Plate  
pages 156-157



**13** Backer Bar  
page 158

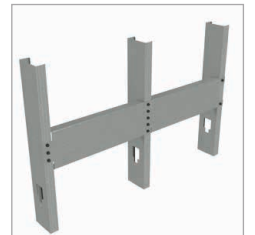

**14** BlazeFrame® Shield  
page 159

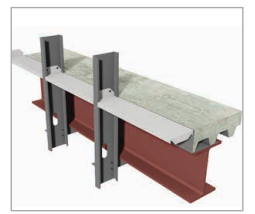

## FastBridge™ Clip

Secures U-channel (cold-rolled channel) framing members for load-bearing or curtain wall applications.

The ClarkDietrich FastBridge clip is used to secure U-Channel or Cold-Rolled Channel (CRC) to structural or non-structural wall studs when used in load-bearing, curtain wall or drywall framing applications. The wall stud friction fit design allows for as little as one screw for the connection to the U-channel.

The FastBridge clip is a stiffened, G90 galvanized steel clip that's tested and designed to facilitate the rapid, efficient installation of 1-1/2" U-channel lateral bracing for exterior curtain wall framing, load-bearing walls or interior partitions constructed of structural or non-structural studs.

- FB33 for use with 20ga-16ga structural studs or ProSTUD® Drywall Studs
- FB43 for use with 20ga-16ga structural studs
- FB68 for use with 16ga-12ga structural studs

### MATERIAL SPECIFICATIONS

**Gauge:** 20 gauge STR (33mils)

**Design Thickness:** 0.0346 inches

**Gauge:** 18 gauge (43mils)

**Design Thickness:** 0.0451 inches

**Gauge:** 14 gauge (68mils)

**Design Thickness:** 0.0713 inches

**Coating:** G90

**ASTM:** A653

### ALTERNATIVE PRODUCTS

- Spazzer® 5400 and 9200 Bridging Bar
- U-Channel with SwiftClip™ LS-Series™ Support Clip
- EasyClip™ U-Series™ Clips

### INSTALLATION

U-Channel is inserted into the stud punchout (spacing as specified by design) and rotated into place (leg down). Place the FastBridge Clip inside the punchout (stiffened wings down) and twist allowing the friction fit design to hold the clip into place. The clip must be firmly seated over the top web of the U-channel. FastBridge clips are fastened using #10 self-drilling screws driven through the clip hole into the U-channel. More than one screw may be needed depending on design. The FastBridge clip should not be used in studs over 8" wide.



### FastBridge™ Clip Angles (FB)

Product code	Thickness				Knockout size	Packaging pcs./bucket
	Mils (Gauge)	Yield strength	Design thickness (in)	Min. thickness (in)		
FB33	33mils (20ga STR)	33ksi	0.0346	0.0329	1-1/2"	200
FB43	43mils (18ga)	50ksi	0.0451	0.0428	1-1/2"	200
FB68	68mils (14ga)	50ksi	0.0713	0.0677	1-1/2"	200

U.S. Patent No. D692,746 and Canadian Patent No. 152,547



### FastBridge™ Clip Angles (FB43) Allowable Clip Capacities (lbs)

Product code	No. of screws to steel framing	Stud depth (in)	Allowable connector capacity	Stud Thickness and Yield Strength		
				33mils (20ga)	43mils (18ga)	54mils (16ga)
FB43	1	3.625	Axial Brace Stiffness (lbs/in)	1140	1330	2270
	2			1220	1480	2270
	1		Axial Brace Strength (lbs)	178	210	273
	2			275	318	424
	1		Torsional Moment (in-lbs)	148	182	208
	2			331	430	556
FB43	1	4.00	Axial Brace Stiffness (lbs/in)	1030	1460	2170
	2			1190	1520	3030
	1		Axial Brace Strength (lbs)	191	213	263
	2			283	321	426
	1		Torsional Moment (in-lbs)	137	182	234
	2			403	403	498
FB43	1	6.00	Axial Brace Stiffness (lbs/in)	790	990	1730
	2			990	1160	1930
	1		Axial Brace Strength (lbs)	107	214	290
	2			263	324	450
	1		Torsional Moment (in-lbs)	166	170	172
	2			296	406	567
FB43	1	8.00	Axial Brace Stiffness (lbs/in)	—	750	1910
	2			—	750	1960
	1		Axial Brace Strength (lbs)	—	212	272
	2			—	302	438
	1		Torsional Moment (in-lbs)	—	152	343
	2			—	461	526

### FastBridge™ Clip Angles (FB68) Allowable Clip Capacities (lbs)

Product code	No. of screws to steel framing	Stud depth (in)	Allowable connector capacity	Stud Thickness and Yield Strength		
				54mils (16ga)	68mils (14ga)	97mils (12ga)
FB68	1	3.625	Axial Brace Stiffness (lbs/in)	3410	4410	6270
	2			4010	6880	7585
	1		Axial Brace Strength (lbs)	465	520	573
	2			665	732	823
	1		Torsional Moment (in-lbs)	332	440	435
	2			735	894	1150
FB68	1	4.00	Axial Brace Stiffness (lbs/in)	3060	3440	6740
	2			3710	4670	8960
	1		Axial Brace Strength (lbs)	475	505	505
	2			676	752	878
	1		Torsional Moment (in-lbs)	382	462	564
	2			724	802	938
FB68	1	6.00	Axial Brace Stiffness (lbs/in)	2270	3240	3200
	2			2710	3870	3530
	1		Axial Brace Strength (lbs)	468	506	515
	2			682	788	885
	1		Torsional Moment (in-lbs)	294	412	670
	2			686	758	1004
FB68	1	8.00	Axial Brace Stiffness (lbs/in)	1940	2500	2530
	2			1960	2810	3015
	1		Axial Brace Strength (lbs)	463	510	517
	2			637	747	898
	1		Torsional Moment (in-lbs)	310	512	674
	2			682	788	963

#### Notes:

- Allowable loads are based on the use of cold-formed steel studs with a minimum yield strength of  $F_y=33\text{ksi}$  and tensile strength of  $F_u=45\text{ksi}$  for 43mils (18ga) or thinner; and a minimum yield strength  $F_y=50\text{ksi}$  and tensile strength  $F_u=65\text{ksi}$  for 54mils (16ga) or thicker.
- Allowable loads are based on 54mils (16ga) u-channel bridging with a minimum yield strength  $F_y=33\text{ksi}$  and tensile strength  $F_u=45\text{ksi}$ .
- Allowable loads are for the bridging connection only. The strength and serviceability of the framing members is the responsibility of the designer.
- Allowable loads are based on #10 self-drilling screws with a nominal diameter of 0.190 in. and a washer diameter of 0.375 in. Fasteners must have a minimum nominal shear strength of  $P_{ss}=1718\text{ lbs}$  and a nominal tensile strength of  $P_{ts}=2654\text{ lbs}$ .
- Allowable loads may not be increased for wind or seismic load.
- Allowable loads are for use when using ASD design methodology. For LRFD loads, multiply ASD allowable loads by 1.6.
- Allowable brace loads are based on ultimate test loads divided by a safety factor. Serviceability limits are not considered. Brace stiffness requirements are detailed in AISI S100 Section D3.3.
- Axial brace stiffness values apply to both ASD and LRFD designs.

## CC33 3/4" Channel Clip

33mils (20 gauge) lateral bracing clip used to secure 3/4" U-channel (cold-rolled channel) to drywall studs.

The ClarkDietrich CC33 clip is used to secure U-Channel or Cold-Rolled Channel (CRC) to non-structural wall studs. The wall stud friction fit design allows for as few as one screw for the connection to the U-Channel.

The CC33 clip is a stiffened, G90 galvanized steel clip that's tested and designed to facilitate the rapid, efficient installation of 3/4" U-Channel lateral bracing for non-structural interior wall framing constructed of ProSTUD® Drywall Framing or non-structural studs. The CC33 clip should not be used in studs over 6" wide.

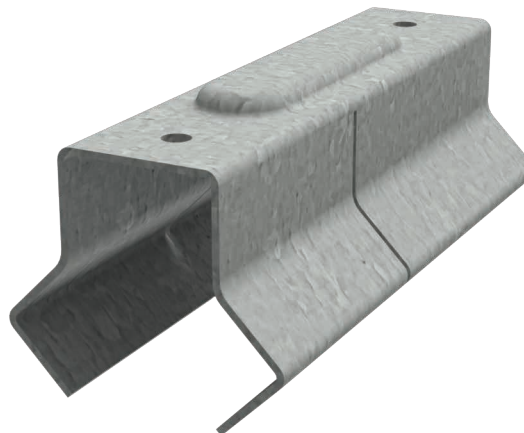

### PRODUCT DIMENSIONS

Made to fit over 3/4" U-Channel and inside a drywall punchout.

**Packaging:** (200) pieces per bucket

**Product weight:** 0.12 lb/piece

### MATERIAL SPECIFICATIONS

**Gauge:** 20 gauge (33mils)

**Design Thickness:** 0.0346 inches

**Coating:** G90

**Yield Strength:** 33ksi

**ASTM:** C645, A1003

### ALTERNATIVE PRODUCTS

- U-Channel with SwiftClip™ LS-Series™ Support Clip
- Spazzer® 9200 Bridging Bar

### INSTALLATION

CC33 clips are fastened using #8 self-drilling screws driven through the clip hole into the U-Channel. More than one screw may be needed depending on design. Design loads & tables can be found at [clarkdietrich.com](http://clarkdietrich.com).



### CC33 3/4" Channel Clip (CC33)

Product code	Thickness		Packaging Pcs./Bucket
	Mils (Gauge)	Design thickness (in)	
CC33	33mils (20ga)	0.0346	200

U.S. Patent No. D822,455

## CC33 3/4" Channel Clip

## DRYWALL BRIDGING CONNECTOR W/ PROSTUD DRYWALL STUDS

Product code	Stud member	Stud thickness (mils)	Allowable Torsional Moment (in-lbs)	
			1 - #8 Screw	2 - #8 Screw
CC33	362PDS125	PDS125-15	50	70
		PDS125-19	70	90
		PDS125-22	85	100
		PDS125-30	90	125
		PDS125-33	90	135
	600PDS125	PDS125-15	70	85
		PDS125-19	95	100
		PDS125-22	95	100
		PDS125-30	100	125
		PDS125-33	100	140

**Notes:**

- Allowable loads are based on cold-formed steel studs with a minimum yield strength specified for ProSTUD Members.
- Allowable loads are based on 54 mils (16ga) u-channel bridging with a minimum yield strength,  $F_y=33\text{ksi}$  and tensile strength,  $F_u=45\text{ksi}$ .
- Allowable loads consider the bridging connection only. It is the responsibility of the designer to verify the strength and serviceability of the framing members.
- Allowable loads are based on #8 self-drilling screws with a nominal diameter of 0.164-in and a head diameter of 0.272-in. Fasteners must have a minimum nominal shear strength,  $P_{ss}=1278\text{-lbs}$  and a nominal tensile strength,  $P_{ts}=586\text{-lbs}$ .
- Screw shear strength is the average value, and tension strength is the lowest value listed on CFSEI Tech Note (F701-12).
- Allowable loads may not be increased for wind or seismic load.
- Allowable loads are for use when utilizing ASD (Allowable Stress Design) methodology. For LRFD loads multiply the ASD tabulated values by 1.6.

## CC33 Maximum Bridging Distance (ft.)

Stud spacing (in)	Stud member	Stud thickness (mils)	Lateral Stud Pressure (psf)			
			5psf		10psf	
			1 - #8 Screw	1 - #8 Screw	2 - #8 Screw	2 - #8 Screw
12	362PDS125	PDS125-15	8	4	8	5
		PDS125-19	8	5	8	7
		PDS125-22	8	7	8	8
		PDS125-30	8	7	8	8
		PDS125-33	8	7	8	8
	600PDS125	PDS125-15	8	6	8	8
		PDS125-19	8	8	8	8
		PDS125-22	8	8	8	8
		PDS125-30	8	8	8	8
		PDS125-33	8	8	8	8
16	362PDS125	PDS125-15	6	3	8	4
		PDS125-19	8	4	8	5
		PDS125-22	8	5	8	6
		PDS125-30	8	5	8	7
		PDS125-33	8	5	8	8
	600PDS125	PDS125-15	8	5	8	6
		PDS125-19	8	6	8	6
		PDS125-22	8	7	8	7
		PDS125-30	8	7	8	8
		PDS125-33	8	7	8	8
24	362PDS125	PDS125-15	4	2	5	3
		PDS125-19	5	3	7	3
		PDS125-22	7	3	8	4
		PDS125-30	7	4	8	5
		PDS125-33	7	4	8	5
	600PDS125	PDS125-15	6	3	8	4
		PDS125-19	8	4	8	4
		PDS125-22	8	4	8	5
		PDS125-30	8	5	8	6
		PDS125-33	8	5	8	7

**Notes:**

- Tabulated maximum bridging distances are for ASD lateral pressures.
- Tabulated maximum bridging distances are based on the CC33 tested connection strength.
- Studs must be checked for unbraced length separately.
- Lateral pressures shall be determined based on the load combinations of the applicable building code.

## Bridging Termination Clip

### U-Channel lateral bracing clip

The ClarkDietrich Bridging Termination clip is used to secure U-Channel or Cold Rolled Channel (CRC) to structural wall studs when used in load-bearing or curtain wall applications. (loads for structural stud gauges of 20, 18, 16, 14 & 12). The BTC's unique design allows for quicker installation in end-of-wall conditions.

The BTC is a stiffened, G90 galvanized steel clip that's tested and designed to facilitate rapid, efficient installation of 1-1/2" U-Channel lateral bracing for exterior curtain wall framing, load-bearing walls or high interior partitions constructed of structural studs.

BTC clips are fastened using #8 self-drilling screws; 2 screws between clip and U-channel and 2 screws between clip and stud flanges. The BTC clips are designed to be used with 3-5/8", 4" or 6" structural studs only.

U.S. Patent No. 10,851,539 B2

### MATERIAL SPECIFICATIONS

**Gauge:** 18 gauge (43mils)

**Design Thickness:** 0.0451 inches

**Gauge:** 16 gauge (54mils)

**Design Thickness:** 0.0566 inches

**Gauge:** 14 gauge (68mils)

**Design Thickness:** 0.0713 inches

**Coating:** G90

**ASTM:** A653/A653M, A1003/A1003M

### ALTERNATIVE PRODUCTS

- FastBridge™ Clip (FB33, FB43 & FB68)
- U-Channel with SwiftClip™ LS-Series™ Support Clip

### INSTALLATION

Install the BTC by sliding the flanges of the clip over the open side of the stud and positioning the clip over the CRC using the guides on the underside of the clip. Once in place, fasten to the CRC using #8 screws. Finally, fasten the flanges of the clip to the stud flange by using #8 screws.

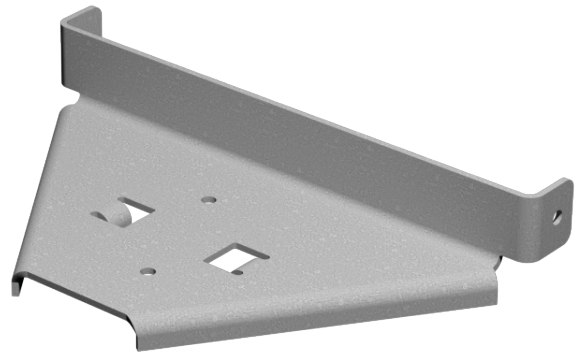

### BTC for 3-5/8" studs

Product code	Thickness				Packaging Pcs./Bucket
	Mils (Gauge)	Yield Strength	Design thickness (in)	Min. thickness (in)	
BTC3-43	43mils (18ga)	50 ksi	0.0451	0.0428	100
BTC3-54	54mils (16ga)		0.0566	0.0538	100
BTC3-68	68mils (14ga)		0.0713	0.0677	100

### BTC for 4" studs

Product code	Thickness				Packaging Pcs./Bucket
	Mils (Gauge)	Yield Strength	Design thickness (in)	Min. thickness (in)	
BTC4-43	43mils (18ga)	50 ksi	0.0451	0.0428	100
BTC4-54	54mils (16ga)		0.0566	0.0538	100
BTC4-68	68mils (14ga)		0.0713	0.0677	100

### BTC for 6" studs

Product code	Thickness				Packaging Pcs./Bucket
	Mils (Gauge)	Yield Strength	Design thickness (in)	Min. thickness (in)	
BTC6-43	43mils (18ga)	50 ksi	0.0451	0.0428	50
BTC6-54	54mils (16ga)		0.0566	0.0538	50
BTC6-68	68mils (14ga)		0.0713	0.0677	50



### Bridging Termination Clip Load Tables

Product code	Stud depth	Clip Mils (Gauge)	Allowable capacities	Stud Thickness, mils (gauge)				
				33mils (20ga)	43mils (18ga)	54mils (16ga)	68mils (14ga)	97mils (12ga)
BTC3	3-5/8"	43mils (18ga)	Axial Brace Stiffness (lbs/in)	2120	2120	2120	2190	2190
BTC4	4"		Axial Brace Strength (lbs)	215	235	240	280	280
BTC6	6"	54mils (16ga)	Torsional Moment (in-lbs)	310	310	320	325	325
BTC3	3-5/8"		Axial Brace Stiffness (lbs/in)	2965	3135	3175	3345	3345
BTC4	4"	Axial Brace Strength (lbs)	320	350	375	410	410	
BTC6	6"	Torsional Moment (in-lbs)	510	515	520	525	525	
BTC3	3-5/8"	68mils (14ga)	Axial Brace Stiffness (lbs/in)	3915	4325	4525	4825	4825
BTC4	4"		Axial Brace Strength (lbs)	460	500	555	570	570
BTC6	6"		Torsional Moment (in-lbs)	760	775	775	790	790

#### Notes:

- Allowable loads are based on the use of cold-formed steel studs with a minimum yield strength,  $F_y=33$  ksi and tensile strength,  $F_u=45$  ksi for 43mils (18ga) or thinner and a minimum yield strength,  $F_y=50$  ksi and tensile strength,  $F_u=65$  ksi for 54mils (16ga) or thicker.
- Allowable loads are based on 54mils (16ga) U-Channel bridging with a minimum yield strength,  $F_y=33$  ksi and tensile strength,  $F_u=45$  ksi.
- Allowable loads are for the termination bridging connection only. The strength and serviceability of the framing members is the responsibility of the designer.
- Allowable loads are based on minimum #8 self drilling with a minimum nominal diameter of 0.163-in and a minimum head diameter of 0.437-in. Fasteners must have a minimum nominal shear strength of,  $P_{ss}=1452$ -lbs and a nominal tensile strength of,  $P_t=2089$  lbs. (See ICC-ESR 1271 for fastener information.)
- Allowable loads are based on the use of 2 screws between clip and U-Channel and 2 screws between clip and stud flanges.
- Allowable loads may not be increased for wind or seismic load.
- Allowable loads are for use when using ASD design methodology. For LRFD loads, multiply ASD allowable loads by 1.6.
- Allowable brace loads were derived from nominal loads obtained from tests, divided by a safety factor. Serviceability limits are not considered. Brace stiffness requirements are detailed in AISI S100 Section D3.3.
- Axial brace stiffness values apply to both ASD and LRFD designs.

## EasyClip™ X-Series™ Clip Angle

Secures U-channel (cold-rolled channel) framing members for lateral bridging, or secures one framing member to another for rigid connections.

ClarkDietrich EasyClip™ X-Series™ clip angles are used to secure U-channel to wall studs for lateral bridging. U-Channel is passed through the stud knockout and an EasyClip X-Series clip is screw attached or welded to provide a rigid connection. X-Series clip angles and U-channel should not be used in lateral bridging when stud width exceeds 6."

### ALTERNATIVE PRODUCTS

FastBridge™ Clip  
 EasyClip™ U-Series™ Clip Angle  
 EasyClip S-Series™ Support Clip  
 SwiftClip™ LS-Series™ Support Clip  
 Spazzer® 5400 and Spazzer® 9200 Spacer Bars

### PRODUCT DIMENSIONS

2" x 2" x 3-3/8"

2" x 2" x 5-3/4"

2" x 2" x 7-3/4"

2" x 2" x 9-3/4"

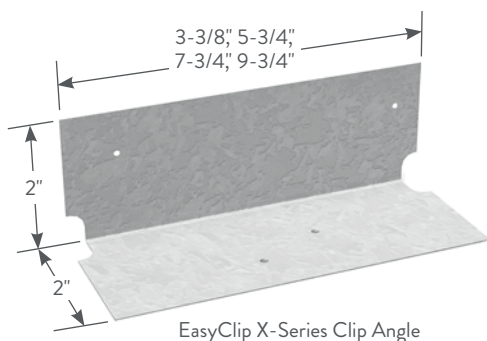

EasyClip X-Series Clip Angle

### MATERIAL SPECIFICATIONS

**Gauge:** 16 gauge (54mils)

**Design Thickness:** 0.0566 inches

**Gauge:** 14 gauge (68mils)

**Design Thickness:** 0.0713 inches

**Gauge:** 12 gauge (97mils)

**Design Thickness:** 0.1017 inches

**Coating:** G90

**Yield Strength:** 50ksi

**ASTM:** A653/A653M

### INSTALLATION

EasyClip X-Series Clip Angles are attached to cold-formed steel (CFS) framing members using #10 minimum self-drilling screws driven through the clip holes into the steel framing. Four pilot clip holes are provided and should be filled when this clip is used in a bridging application. This clip should not be more than 1/4" less in width than the cold-formed framing member.



## EasyClip™ X-Series™ Clip Angles

Product code	Thickness		Size (in)	Packaging Pcs./Bucket
	Mils (Gauge)	Design thickness (in)		
X543	54mils (16ga)	0.0566	2 x 2 x 3-3/8	200
X545	54mils (16ga)	0.0566	2 x 2 x 5-3/4	170
X547	54mils (16ga)	0.0566	2 x 2 x 7-3/4	100
X549	54mils (16ga)	0.0566	2 x 2 x 9-3/4	100
X683	68mils (14ga)	0.0713	2 x 2 x 3-3/8	200
X685	68mils (14ga)	0.0713	2 x 2 x 5-3/4	100
X687	68mils (14ga)	0.0713	2 x 2 x 7-3/4	100
X689	68mils (14ga)	0.0713	2 x 2 x 9-3/4	80
X973	97mils (12ga)	0.1017	2 x 2 x 3-3/8	100
X975	97mils (12ga)	0.1017	2 x 2 x 5-3/4	100
X977	97mils (12ga)	0.1017	2 x 2 x 7-3/4	60
X979	97mils (12ga)	0.1017	2 x 2 x 9-3/4	60

TYPICAL CONSTRUCTION DETAILS

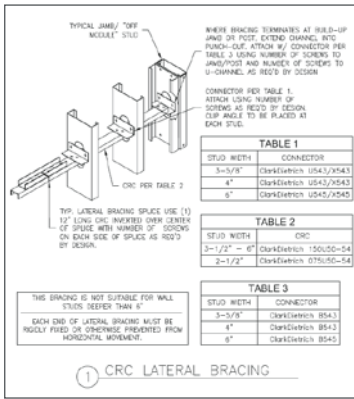

Visit our CAD Library at [clarkdietrich.com](http://clarkdietrich.com) to view or download construction details in .dwg, .dxf, and .pdf formats.

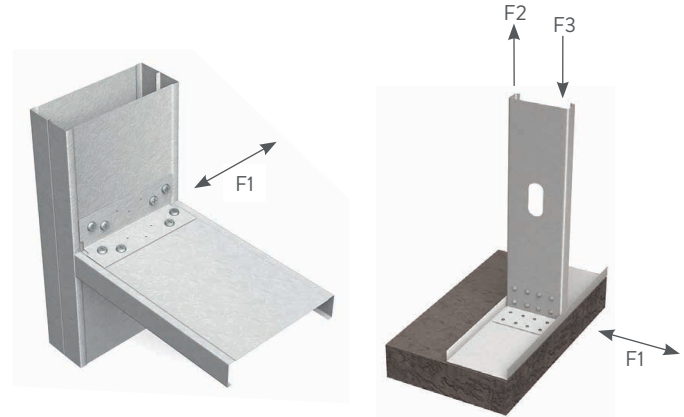

EasyClip™ X-Series™ Clip Angles Allowable Clip Capacities (lbs) USING #10-16 SELF-DRILLING SCREWS

Product code	No. of screws to steel framing	Stud Thickness and Yield Strength								
		20ga (33mils) 33ksi			18ga (43mils) 33ksi			16ga (54mils) 50ksi		
		F1	F2	F3	F1	F2	F3	F1	F2	F3
X543	4	390 (390)	150 (531)	531	578 (578)	150 (788)	788	1028 (904)	150 (1400)	1400
	3	449 (449)	231 (531)	531	666 (666)	231 (788)	788	1184 (1184)	231 (1400)	1400
X545	5	677 (677)	231 (885)	885	1004 (1004)	231 (1313)	1313	1785 (1785)	231 (2333)	2333
	7	974 (974)	231 (1239)	1239	1445 (1445)	231 (1838)	1838	2568 (1810)	231 (2617)	3267
X547	5	761 (761)	311 (885)	885	1130 (1130)	311 (1313)	1313	2007 (2007)	311 (2333)	2333
	7	1031 (1031)	311 (1239)	1239	1529 (1529)	311 (1838)	1838	2718 (2718)	311 (3267)	3267
X549	9	1298 (1298)	311 (1593)	1593	1926 (1926)	311 (2363)	2363	3423 (2789)	311 (3527)	4200
	7	1102 (1102)	391 (1239)	1239	1635 (1635)	391 (1838)	1838	2905 (2905)	391 (3267)	3267
X683	9	1397 (1397)	391 (1593)	1593	2072 (2072)	391 (2363)	2363	3682 (3682)	391 (4200)	4200
	11	1690 (1690)	391 (1947)	1947	2508 (2508)	391 (2889)	2889	4457 (3779)	391 (4437)	5133
X685	4	390 (390)	238 (531)	531	578 (578)	238 (788)	788	1028 (1028)	238 (1400)	1400
	3	449 (449)	365 (531)	531	666 (666)	365 (788)	788	1184 (1184)	365 (1400)	1400
X687	5	677 (677)	365 (885)	885	1004 (1004)	365 (1313)	1313	1785 (1785)	365 (2333)	2333
	7	974 (974)	365 (1239)	1239	1445 (1445)	365 (1838)	1838	2568 (2278)	365 (3267)	3267
X689	5	761 (761)	492 (885)	885	1130 (1130)	492 (1313)	1313	2007 (2007)	492 (2333)	2333
	7	1031 (1031)	492 (1239)	1239	1529 (1529)	492 (1838)	1838	2718 (2718)	492 (3267)	3267
X973	9	1298 (1298)	492 (1593)	1593	1926 (1926)	492 (2363)	2363	3423 (3423)	492 (4200)	4200
	7	1102 (1102)	619 (1239)	1239	1635 (1635)	619 (1838)	1838	2905 (2905)	619 (3267)	3267
X975	9	1397 (1397)	619 (1593)	1593	2072 (2072)	619 (2363)	2363	3682 (3682)	619 (4200)	4200
	11	1690 (1690)	619 (1947)	1947	2508 (2508)	619 (2889)	2889	4457 (4457)	619 (5133)	5133
X977	4	390 (390)	485 (531)	531	578 (578)	485 (788)	788	1028 (1028)	485 (1400)	1400
	3	449 (449)	531 (531)	531	666 (666)	743 (788)	788	1184 (1184)	743 (1400)	1400
X979	5	677 (677)	743 (885)	885	1004 (1004)	743 (1313)	1313	1785 (1785)	743 (2333)	2333
	7	974 (974)	743 (1239)	1239	1445 (1445)	743 (1838)	1838	2568 (2568)	743 (3267)	3267
X977	5	761 (761)	885 (885)	885	1130 (1130)	1002 (1313)	1313	2007 (2007)	1002 (2333)	2333
	7	1031 (1031)	1002 (1239)	1239	1529 (1529)	1002 (1838)	1838	2718 (2718)	1002 (3267)	3267
X979	9	1298 (1298)	1002 (1593)	1593	1926 (1926)	1002 (2363)	2363	3423 (3423)	1002 (4200)	4200
	7	1102 (1102)	1239 (1239)	1239	1635 (1635)	1260 (1838)	1838	2905 (2905)	1260 (3267)	3267
X979	9	1397 (1397)	1260 (1593)	1593	2072 (2072)	1260 (2363)	2363	3682 (3682)	1260 (4200)	4200
	11	1690 (1690)	1260 (1947)	1947	2508 (2508)	1260 (2889)	2889	4457 (4457)	1260 (5133)	5133

Notes:

Screw Capacity Notes:

- The tabulated value indicates the number of screws in a single clip leg attached to the cold-formed steel (CFS) framing.
- Screws shall be attached in a symmetric manner starting at the top and bottom and moving toward the center.
- The allowable values for F1 are based only on the shear capacity of the clip leg attached to the CFS framing. The capacity of the attachment to other materials and structures must be checked separately.
- The allowable values for F2 assume mechanical fasteners are attached to the structure, and are located no more than 1" away from the angle bend. Mechanical fasteners to other materials and structures must be checked separately.
- This table is intended for use by qualified engineers only. It is the responsibility of the engineer to verify that the tabulated values apply to a specific connection application.
- When clips have combinations of F1, F2 and F3, use a linear interaction for combinations of F1 and F3, and a squared interaction for combinations of F1 and F2.

7 Allowable loads have not been increased 33% for wind or seismic.

8 For connections made to 14ga (68mils) and 12ga (97mils), use the tabulated values for 16ga (54mils), 50ksi.

9 It is the responsibility of the design professional to detail the drawings for proper clip attachment.

10 Contact ClarkDietrich Technical Services at 888-437-3244 for assistance.

Weld Capacity Notes:

- F1 and F2 values in parentheses are maximum shear and tension capacities when the clips are welded to the base structure (min 3/16" — 36ksi steel).
- Listed weld capacities are computed assuming an E70XX welding rod or wire.
- The clips are to be welded to the structure along the back corner along the complete length of the clip. When secondary welds are used to hold the clip in place, they are not used in capacity calculations.

## Spazzer® 9200 Spacer Bar

Facilitates the rapid erection of interior, nonload-bearing, nonstructural studs into a rigid, accurately laid out gridwork.

The TradeReady® Spazzer® 9200 spacer bar is a prenotched, 20 gauge, galvanized steel spacer and bridging bar. The Spazzer 9200 bar facilitates rapid erection of studs into a rigid, accurately laid out gridwork that has excellent resistance to stud rotation and displacement. Hanging drywall is also faster and easier because the Spazzer 9200 bar eliminates the bow that often occurs in tall interior studs. TradeReady Spazzer 9200 bar is a 20 gauge bar that is 50" long and prenotched to hold studs rigidly on 16" or 24" centers. The slots have been pre-engineered to hold studs in place by utilizing "shear" to bridge studs into a rigid gridwork. Eliminates clip angles and saves up to 40% in combined labor and material costs.

### ALTERNATIVE PRODUCTS

U-Channel with EasyClip™ U-Series™ Clip Angle  
 U-Channel with SwiftClip™ LS-Series™ Support Clip  
 Spazzer® 5400 Spacer Bar



### PRODUCT DIMENSIONS

7/8" x 7/8" x 50"

### MATERIAL SPECIFICATIONS

**Gauge:** 20 gauge (33mils)

**Design Thickness:** 0.0346 inches

**Coating:** G40

**Yield Strength:** 33ksi

**ASTM:** C645, A653/A653M

### INSTALLATION

Insert the prenotched, 50" Spazzer bar through the appropriate stud punchouts and rotate the bridging bar to engage or grip the stud. Use the prenotched slots to automatically lay out studs on 16" or 24" centers. Press the Spazzer bar firmly into place. Overlap the last slot with the next piece of Spazzer and continue to repeat the process.

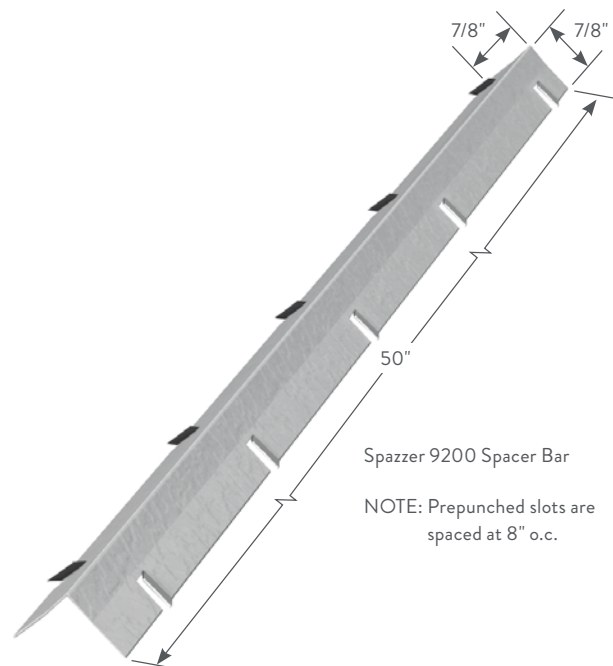

## Spazzer® 9200 Spacer Bar (SPZD)

Product code	Thickness		Size (in)	Packaging	
	Mils (Gauge)	Design thickness (in)		Pcs./Carton	Pcs./Skid
SPZD	33mils (20ga)	0.0346	7/8 x 7/8 x 50	25	1350



## Spazzer® 5400 Spacer Bar, Bar Guard™ & Grommet

Engineered to facilitate the rapid erection of exterior curtain wall framing.

ClarkDietrich TradeReady® Spazzer® 5400 (16 gauge and 18 gauge) spacer bar is a pre-notched, galvanized steel spacer and bridging bar, engineered to facilitate the rapid, efficient erection of exterior curtain wall framing, load-bearing walls and high interior partitions constructed of structural studs. Until now, most bridging in steel studs was accomplished with cold-rolled channel that required bridging clips or welding. The Spazzer bridging bar is equipped with proprietary prepunched slots that reduce installation costs up to 40% and provide excellent torsional and lateral stud restraint. The Spazzer Bar Guard™ retainer clip or the Spazzer snap-in grommet should be used to secure the Spazzer bar when used in load-bearing applications.

### ALTERNATIVE PRODUCTS

U-Channel with EasyClip™ U-Series™, U-Channel with SwiftClip™ LS-Series™ Support Clip, U-Channel with FastBridge Clip, Block and Strap

### PRODUCT DIMENSIONS

1-1/4" x 1-1/4" x 50"

### MATERIAL SPECIFICATIONS

**Gauge:** 16 gauge (54mils)

**Design Thickness:** 0.0566 inches

**Gauge:** 18 gauge (43mils)

**Design Thickness:** 0.0451 inches

**Coating:** CP60

**Yield Strength:** 50ksi

**ASTM:** A653/A653M, C955

### Spazzer® 5400 Spacer Bar (SPZS)

Product code	Thickness		Size (in)	Packaging	
	Mils (Gauge)	Design thickness (in)		Pcs./Carton	Pcs./Skid
SPZS-54	54mils (16ga)	0.0566	1-1/4 x 1-1/4 x 50	20	680
SPZS-43	43mils (18ga)	0.0451	1-1/4 x 1-1/4 x 50	20	680

### Spazzer® Bar Guard™ (SPBG) and Spazzer® Grommet (SPGR)

Product code	Size (in)	Packaging Pcs./Carton
SPBG	3-1/4 x 1-5/8	100
SPGR	1-1/2 x 4	100

### LOAD-BEARING WALL INSTALLATION

The TradeReady Spazzer bar is passed through the stud knockouts and rotated 90° into position, engaging each side of the knockout. For load-bearing studs, the Spazzer bar guard bar retainer clip and the Spazzer snap-in grommet both require screws to keep the bar in place. The TradeReady Spazzer bar should be installed at a maximum 4' o.c. vertically or per specification. The Spazzer 5400 is not designed for use with 12ga and heavier structural studs and should not be used in studs over 8" wide.

### NONLOAD-BEARING WALL INSTALLATION

The TradeReady Spazzer bar is passed through the stud knockouts and rotated 90° into position, engaging each side of the knockout. For 20 gauge studs, the Spazzer bar guard retainer clip and the Spazzer snap-in grommet both require screws to keep the bar in place. The TradeReady Spazzer bar should be installed at maximum 5' o.c. vertically or per specification. The Spazzer 5400 is not designed for use with 12ga and heavier structural studs and should not be used in studs over 8" wide.

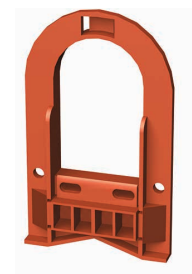
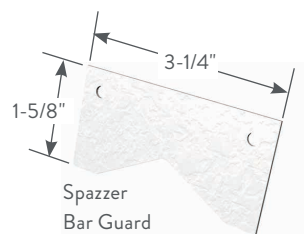

Spazzer Snap-in Grommet

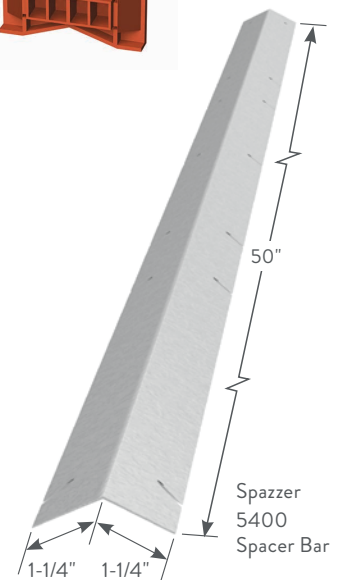

Spazzer 5400 Spacer Bar

## Spazzer® 5400 Spacer Bar (16ga)

## Spazzer® 5400 Spacer Bar Connection Strength and Stiffness

Product code	Stud depth (in)	Allowable Capacities	Stud Thickness mils (ga)			
			33mils (20ga)	43mils (18ga)	54mils (16ga)	68mils (14ga)
SPZS54	3-5/8	Brace stiffness (lbs/in)	1320	1984	2792	3120
		Brace strength (lbs)	310	420	570	570
		Torsional Moment (in-lbs)	325	400	535	630
	6	Brace stiffness (lbs/in)	920	1680	2240	2400
		Brace strength (lbs)	300	400	555	555
		Torsional Moment (in-lbs)	265	365	610	705
	8	Brace stiffness (lbs/in)	-	1080	1440	2176
		Brace strength (lbs)	-	395	525	525
		Torsional Moment (in-lbs)	-	405	560	680

**Notes:**

- 1 Allowable loads are based on the use of cold-formed steel studs with a minimum yield strength,  $F_y=33$  ksi and tensile strength,  $F_u=45$  ksi for 43mils (18ga) or thinner and a minimum yield strength,  $F_y=50$  ksi and tensile strength,  $F_u=65$  ksi for 54mils (16ga) or thicker.
- 2 Allowable loads are based on 54mils (16ga) 5400 Spazzer Bar with a minimum yield strength,  $F_y=50$  ksi and tensile strength,  $F_u=65$  ksi.
- 3 Allowable loads are for the bridging connection only. The strength and serviceability of the framing members is the responsibility of the designer.
- 4 Allowable loads may not be increased for wind or seismic load.
- 5 Allowable loads are for use when using ASD design methodology. For LRFD loads, multiply ASD allowable loads by 1.6.
- 6 Allowable brace loads are based on ultimate test loads divided by a safety factor. Serviceability limits are not considered. Brace stiffness requirements are detailed in AISI S100 Section D3.3.
- 7 Axial brace stiffness values apply to both ASD and LRFD designs.
- 8 Listed Spazzer Bar capacities are based on Spazzer Bar fully seated in the bottom of the stud knockout as shown in Figure-1.

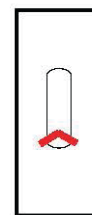
**Figure-1**

Spazzer® 5400 Spacer Bar Maximum Bridging Distance (ft.)

Product code	Stud spacing (in)	Stud section (in)	Stud thickness mils (ga)	Lateral stud pressure (psf)										
				5	10	15	20	25	30	35	40	45	50	
SPZS54	12	362S162	33mils (20ga)	8	8	8	8	7	5	5	4	4	-	
			43mils (18ga)	8	8	8	8	8	7	6	5	5	4	
			54mils (16ga)	8	8	8	8	8	8	8	7	6	6	6
			68mils (14ga)	8	8	8	8	8	8	8	8	7	7	7
		362S200	33mils (20ga)	8	8	8	6	5	4	4	-	-	-	-
			43mils (18ga)	8	8	8	8	6	5	4	4	-	-	-
			54mils (16ga)	8	8	8	8	8	7	6	5	5	4	4
			68mils (14ga)	8	8	8	8	8	8	7	6	6	5	5
		600S162	33mils (20ga)	8	8	8	8	6	5	4	4	-	-	-
			43mils (18ga)	8	8	8	8	8	7	6	5	5	4	4
			54mils (16ga)	8	8	8	8	8	8	8	8	8	7	7
			68mils (14ga)	8	8	8	8	8	8	8	8	8	8	8
		600S200	33mils (20ga)	8	8	8	6	5	4	-	-	-	-	-
			43mils (18ga)	8	8	8	8	7	5	5	4	4	-	-
			54mils (16ga)	8	8	8	8	8	8	8	7	6	6	6
			68mils (14ga)	8	8	8	8	8	8	8	8	8	7	6
		800S162	43mils (18ga)	8	8	8	8	8	8	8	7	6	5	5
			54mils (16ga)	8	8	8	8	8	8	8	8	8	8	8
			68mils (14ga)	8	8	8	8	8	8	8	8	8	8	8
			43mils (18ga)	8	8	8	8	8	7	6	5	4	4	4
		800S200	54mils (16ga)	8	8	8	8	8	8	8	7	6	6	6
			68mils (14ga)	8	8	8	8	8	8	8	8	8	8	7
			33mils (20ga)	8	8	8	6	5	4	4	-	-	-	-
			43mils (18ga)	8	8	8	8	6	5	4	4	-	-	-
	16	362S162	54mils (16ga)	8	8	8	8	8	7	6	5	5	4	
			68mils (14ga)	8	8	8	8	8	8	7	6	5	5	
			33mils (20ga)	8	8	6	5	4	-	-	-	-	-	-
			43mils (18ga)	8	8	8	8	6	5	4	4	-	-	-
		362S200	54mils (16ga)	8	8	8	8	6	5	5	4	4	-	-
			68mils (14ga)	8	8	8	8	8	6	5	5	4	4	4
			33mils (20ga)	8	8	8	6	5	4	-	-	-	-	-
			43mils (18ga)	8	8	8	8	7	5	5	4	4	-	-
		600S162	54mils (16ga)	8	8	8	8	8	8	8	7	6	6	6
			68mils (14ga)	8	8	8	8	8	8	8	8	8	7	6
			33mils (20ga)	8	8	6	4	4	-	-	-	-	-	-
			43mils (18ga)	8	8	8	6	5	4	-	-	-	-	-
		600S200	54mils (16ga)	8	8	8	8	8	7	6	5	5	4	4
			68mils (14ga)	8	8	8	8	8	8	7	6	5	5	5
			43mils (18ga)	8	8	8	8	8	7	6	5	4	4	4
			54mils (16ga)	8	8	8	8	8	8	8	7	6	6	6
		800S162	68mils (14ga)	8	8	8	8	8	8	8	8	8	8	7
			43mils (18ga)	8	8	8	8	8	7	6	5	4	4	4
			54mils (16ga)	8	8	8	8	8	8	8	8	7	6	6
			68mils (14ga)	8	8	8	8	8	8	8	8	8	8	7
		800S200	43mils (18ga)	8	8	8	7	6	5	4	4	-	-	-
			54mils (16ga)	8	8	8	8	8	7	6	5	5	4	4
			68mils (14ga)	8	8	8	8	8	8	7	6	6	5	5
			33mils (20ga)	8	8	5	4	-	-	-	-	-	-	-
24	362S162	43mils (18ga)	8	8	7	5	4	-	-	-	-	-		
		54mils (16ga)	8	8	8	7	6	5	4	-	-	-		
		68mils (14ga)	8	8	8	8	7	5	5	4	4	-	-	
		33mils (20ga)	8	6	4	-	-	-	-	-	-	-	-	
	362S200	43mils (18ga)	8	8	5	4	-	-	-	-	-	-	-	
		54mils (16ga)	8	8	7	5	4	4	-	-	-	-	-	
		68mils (14ga)	8	8	8	6	5	4	4	-	-	-	-	
		33mils (20ga)	8	8	5	4	-	-	-	-	-	-	-	
	600S162	43mils (18ga)	8	8	7	5	4	4	-	-	-	-	-	
		54mils (16ga)	8	8	8	8	7	6	5	5	4	4	4	
		68mils (14ga)	8	8	8	8	8	7	6	5	5	4	4	
		33mils (20ga)	8	6	4	-	-	-	-	-	-	-	-	
	600S200	43mils (18ga)	8	8	5	4	-	-	-	-	-	-	-	
		54mils (16ga)	8	8	8	7	6	5	4	-	-	-	-	
		68mils (14ga)	8	8	8	8	6	5	5	4	4	-	-	
		43mils (18ga)	8	8	8	7	5	4	4	-	-	-	-	
	800S162	54mils (16ga)	8	8	8	8	8	6	5	5	4	4	4	
		68mils (14ga)	8	8	8	8	8	8	7	6	5	5	5	
		43mils (18ga)	8	8	8	8	8	7	6	5	4	4	4	
		54mils (16ga)	8	8	8	8	8	8	8	7	6	5	5	
	800S200	43mils (18ga)	8	8	7	5	4	-	-	-	-	-	-	
		54mils (16ga)	8	8	8	7	6	5	4	-	-	-	-	
		68mils (14ga)	8	8	8	8	7	6	5	4	4	-	-	

- Notes:**
- 1 Tabulated maximum bridging distances are for ASD lateral pressures.
  - 2 Tabulated maximum bridging distances are based on the tested connection strength.
  - 3 Studs must be checked for unbraced length separately.
  - 4 Lateral pressures shall be determined based on the load combinations of the applicable building code.
  - 5 For designs using 2009 IBC and earlier, wind pressures are at the working stress level and may be used directly.
  - 6 For designs using 2012 IBC and 2015 IBC, wind pressures are at the strength level and must be multiplied by 0.6 for ASD load combinations.

## Spazzer® 5400 Spacer Bar (18ga)

## Spazzer® 5400 Spacer Bar Connection Strength and Stiffness

Product code	Stud depth (in)	Allowable Capacities	Stud Thickness mils (ga)			
			33mils (20ga)	43mils (18ga)	54mils (16ga)	68mils (14ga)
SPZS43	3-5/8	Brace stiffness (lbs/in)	525	735	1160	1380
		Brace strength (lbs)	310	360	360	360
		Torsional Moment (in-lbs)	150	240	300	300
	6	Brace stiffness (lbs/in)	290	420	520	890
		Brace strength (lbs)	300	340	340	340
		Torsional Moment (in-lbs)	210	250	290	290
	8	Brace stiffness (lbs/in)	-	240	430	650
		Brace strength (lbs)	-	290	320	320
		Torsional Moment (in-lbs)	-	230	250	280

**Notes:**

- 1 Allowable loads are based on the use of cold-formed steel studs with a minimum yield strength,  $F_y=33$  ksi and tensile strength,  $F_u=45$  ksi for 43mils (18ga) or thinner and a minimum yield strength,  $F_y=50$  ksi and tensile strength,  $F_u=65$  ksi for 54mils (16ga) or thicker.
- 2 Allowable loads are based on 43mils (18ga) 4300 Spazzer Bar with a minimum yield strength,  $F_y=33$  ksi and tensile strength,  $F_u=45$  ksi.
- 3 Allowable loads are for the bridging connection only. The strength and serviceability of the framing members is the responsibility of the designer.
- 4 Allowable loads may not be increased for wind or seismic load.
- 5 Allowable loads are for use when using ASD design methodology. For LRFD loads, multiply ASD allowable loads by 1.6.
- 6 Allowable brace loads are based on ultimate test loads divided by a safety factor. Serviceability limits are not considered. Brace stiffness requirements are detailed in AISI S100 Section D3.3.
- 7 Axial brace stiffness values apply to both ASD and LRFD designs.
- 8 Listed Spazzer Bar capacities are based on Spazzer Bar fully seated in the bottom of the stud knockout as shown in Figure-1.

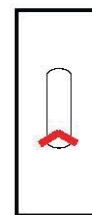
**Figure-1**

## Spazzer® 5400 Spacer Bar Maximum Bridging Distance (ft.)

Product code	Stud spacing (in)	Stud section (in)	Stud thickness mils (ga)	Lateral stud pressure (psf)											
				5	10	15	20	25	30	35	40	45	50		
SPZS43	12	362S162	33mils (20ga)	8	8	5	4	-	-	-	-	-	-	-	-
			43mils (18ga)	8	8	8	6	5	4	4	4	-	-	-	
			54mils (16ga)	8	8	8	8	6	5	4	4	4	-	-	
			68mils (14ga)	8	8	8	8	6	5	4	4	4	-	-	
		362S200	33mils (20ga)	8	6	4	-	-	-	-	-	-	-	-	-
			43mils (18ga)	8	8	6	5	4	-	-	-	-	-	-	
			54mils (16ga)	8	8	8	6	5	4	-	-	-	-	-	
			68mils (14ga)	8	8	8	6	5	4	-	-	-	-	-	
		600S162	33mils (20ga)	8	8	8	6	5	4	4	4	-	-	-	
			43mils (18ga)	8	8	8	7	6	5	4	4	-	-	-	
			54mils (16ga)	8	8	8	8	7	6	5	4	4	-	-	
			68mils (14ga)	8	8	8	8	7	6	5	4	4	4	4	
		600S200	33mils (20ga)	8	8	6	5	4	-	-	-	-	-	-	
			43mils (18ga)	8	8	7	6	4	4	-	-	-	-	-	
			54mils (16ga)	8	8	8	7	5	4	4	-	-	-	-	
			68mils (14ga)	8	8	8	7	5	4	4	-	-	-	-	
		800S162	43mils (18ga)	8	8	8	8	6	5	4	4	-	-	-	
			54mils (16ga)	8	8	8	8	7	6	5	4	4	-	-	
			68mils (14ga)	8	8	8	8	8	6	5	4	5	4	4	
			43mils (18ga)	8	8	8	6	5	4	-	-	-	-	-	
		800S200	54mils (16ga)	8	8	8	6	5	4	4	-	-	-	-	
			68mils (14ga)	8	8	8	7	6	5	4	4	-	-	-	
			33mils (20ga)	8	6	4	-	-	-	-	-	-	-	-	
			43mils (18ga)	8	8	6	5	4	-	-	-	-	-	-	
	16	362S162	54mils (16ga)	8	8	8	6	5	4	-	-	-	-	-	
			68mils (14ga)	8	8	8	6	5	4	-	-	-	-	-	
			33mils (20ga)	8	4	-	-	-	-	-	-	-	-	-	
			43mils (18ga)	8	7	5	4	-	-	-	-	-	-	-	
		362S200	54mils (16ga)	8	8	6	4	4	-	-	-	-	-	-	
			68mils (14ga)	8	8	6	4	4	-	-	-	-	-	-	
			33mils (20ga)	8	8	6	5	4	-	-	-	-	-	-	
			43mils (18ga)	8	8	7	6	4	4	-	-	-	-	-	
		600S162	54mils (16ga)	8	8	8	7	5	4	4	-	-	-	-	
			68mils (14ga)	8	8	8	7	5	4	4	-	-	-	-	
			33mils (20ga)	8	7	5	-	-	-	-	-	-	-	-	
			43mils (18ga)	8	8	6	4	-	-	-	-	-	-	-	
		600S200	54mils (16ga)	8	8	7	5	4	-	-	-	-	-	-	
			68mils (14ga)	8	8	7	5	4	-	-	-	-	-	-	
			43mils (18ga)	8	8	8	6	5	4	-	-	-	-	-	
			68mils (14ga)	8	8	8	7	5	4	4	-	-	-	-	
		800S162	43mils (18ga)	8	8	8	6	5	4	-	-	-	-	-	
			54mils (16ga)	8	8	8	6	5	4	4	-	-	-	-	
			68mils (14ga)	8	8	8	7	6	5	4	4	-	-	-	
			43mils (18ga)	8	8	6	4	-	-	-	-	-	-	-	
		800S200	54mils (16ga)	8	8	6	5	4	-	-	-	-	-	-	
			68mils (14ga)	8	8	7	5	4	4	-	-	-	-	-	
			33mils (20ga)	8	4	-	-	-	-	-	-	-	-	-	
			43mils (18ga)	8	6	4	-	-	-	-	-	-	-	-	
24	362S162	54mils (16ga)	8	8	5	4	-	-	-	-	-	-			
		68mils (14ga)	8	8	5	4	-	-	-	-	-	-			
		33mils (20ga)	6	-	-	-	-	-	-	-	-	-	-		
		43mils (18ga)	8	5	-	-	-	-	-	-	-	-	-		
	362S200	54mils (16ga)	8	6	4	-	-	-	-	-	-	-	-		
		68mils (14ga)	8	6	4	-	-	-	-	-	-	-	-		
		33mils (20ga)	8	6	4	-	-	-	-	-	-	-	-		
		43mils (18ga)	8	7	5	4	-	-	-	-	-	-	-		
	600S162	54mils (16ga)	8	8	6	4	-	-	-	-	-	-	-		
		68mils (14ga)	8	8	6	4	4	-	-	-	-	-	-		
		33mils (20ga)	8	5	-	-	-	-	-	-	-	-	-		
		43mils (18ga)	8	8	5	4	-	-	-	-	-	-	-		
	600S200	54mils (16ga)	8	7	4	-	-	-	-	-	-	-	-		
		68mils (14ga)	8	7	4	-	-	-	-	-	-	-	-		
		43mils (18ga)	8	8	5	4	-	-	-	-	-	-	-		
		68mils (14ga)	8	8	6	4	-	-	-	-	-	-	-		
	800S162	54mils (16ga)	8	8	6	4	-	-	-	-	-	-	-		
		68mils (14ga)	8	8	6	5	4	-	-	-	-	-	-		
		43mils (18ga)	8	6	4	-	-	-	-	-	-	-	-		
		68mils (14ga)	8	6	4	-	-	-	-	-	-	-	-		
	800S200	54mils (16ga)	8	6	4	-	-	-	-	-	-	-	-		
		68mils (14ga)	8	7	5	4	-	-	-	-	-	-	-		

**Notes:**

- 1 Tabulated maximum bridging distances are for ASD lateral pressures.
- 2 Tabulated maximum bridging distances are based on the tested connection strength.
- 3 Studs must be checked for unbraced length separately.
- 4 Lateral pressures shall be determined based on the load combinations of the applicable building code.
- 5 For designs using 2009 IBC and earlier, wind pressures are at the working stress level and may be used directly.
- 6 For designs using 2012 IBC and 2015 IBC, wind pressures are at the strength level and must be multiplied by 0.6 for ASD load combinations.

## Spazzer® Bar Fly Clip

A prepunched clip that eliminates the need for cutting and bending when using the Spazzer® 5400 Spacer Bar to facilitate rapid installation of exterior curtain wall framing.

The Spazzer bar fly clip is a secure, fast and efficient way to finish a wall section when using the TradeReady® Spazzer 5400 spacer bar to facilitate the rapid erection of curtain wall or load-bearing framing. Traditionally, at the end of a section, the Spazzer bar would need to be cut and bent to keep the bar in place. With the new Spazzer bar fly clip, installation is as easy as fastening the prepunched clip to the stud and the Spazzer bar. The excess Spazzer bar is cut and installation is complete.

The Spazzer fly clip is the perfect solution for installing off-module studs with the 5400 series Spazzer bar. Simply cut the Spazzer bar just short of the stud web, and use the Spazzer fly clip to quickly connect the Spazzer bar to the face of the stud with self-drilling framing screws.

### ALTERNATIVE PRODUCTS

Traditional cutting and bending

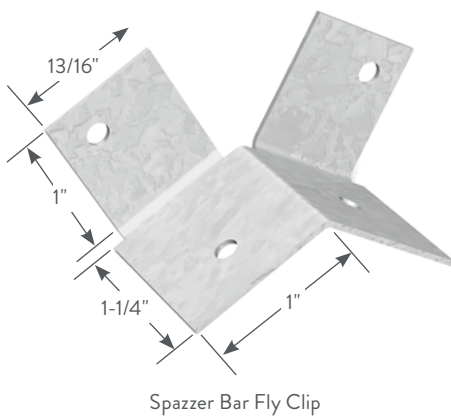

### Spazzer® Bar Fly Clip (SFLY)

Product code	Size (in)	Packaging Pcs./Carton
SFLY	1 x 1-1/4 x 1	100

### PRODUCT DIMENSIONS

1" x 1-1/4" x 1"

### MATERIAL SPECIFICATIONS

**Gauge:** 18 gauge (43mils)

**Design Thickness:** 0.0451 inches

**Coating:** G90

**Yield Strength:** 50ksi

**ASTM:** A653/A653M

### LOAD-BEARING WALL INSTALLATION

The TradeReady Spazzer 5400 spacer bar is passed through the stud knockouts and rotated 90° into position, engaging each side of the knockout. In load-bearing applications, some type of attachment is required to keep the bar in place—the Spazzer bar fly clip is an optimum solution. The TradeReady Spazzer 5400 bar should be installed at a maximum 4' o.c. vertically or per specifications. The Spazzer bar should not be used in studs over 6" wide.

### TYPICAL CONSTRUCTION DETAILS

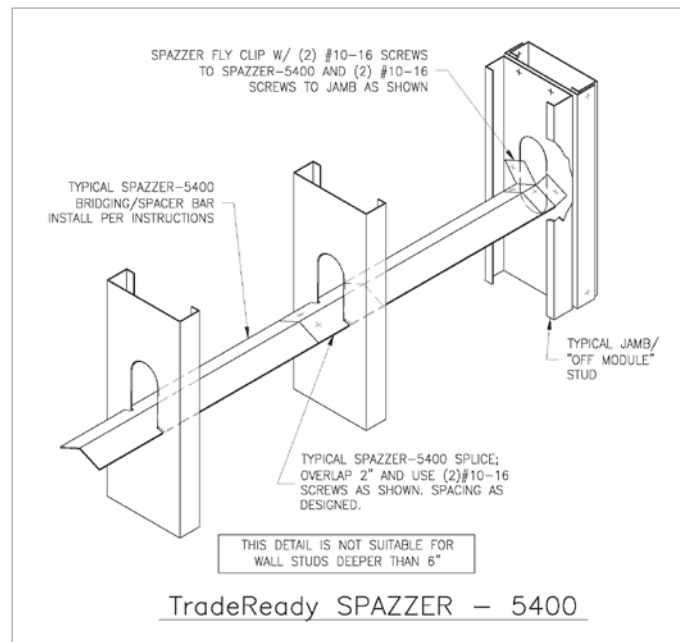

Visit our CAD Library at [clarkdietrich.com](http://clarkdietrich.com) to view or download construction details in .dwg, .dxf, and .pdf formats.

## FastBack™ Backing System

Reduces finishing time with no exposed fasteners on the face of the product.

The FastBack™ backing system features a universal design that works with studs in either direction—concealing fasteners on the face of the product. The system creates an interlocked design between the stud and track for baseboard backing installations; and a cutaway design allows backing and bracing to be installed all the way to the floor. Optional pre-cut and fire-rated D-Blaze® or FlamePRO® Wood Backing is sized to fit 12," 16" and 24" o.c. spacing and can be used with the FBBC5 or FBBC10 clip. Available for overnight delivery. FBBC5-2X, 162-FBBC5-2X and 200-FBBC5-2X are designed to support traditional 2X lumber.

### INSTALLATION

Rotate the FastBack clip over the flange of the stud until it sits flush. Fasten into place using drywall screws in the pre-drilled holes. Place wood onto tabs and fasten into place using standard drywall screws.



### FastBack™ Backing System

Product code	Stud Flange (F)	Height (H)	Backing (B)	Packaging Pcs./Carton
FBBC5	1-1/4"	5-1/8"	3/4" (5 ply)	100
FBBC10	1-1/4"	10-1/4"	3/4" (5 ply)	100
FBBC5-2X	1-1/4"	5-1/8"	3/4" (5 ply)	100
162-FBBC-2X	1-5/8"	5-1/8"	1-1/2" (2X lumber)	100
200-FBBC5-2X	2"	5-1/8"	1-1/2" (2X lumber)	100

### Wood Backing

Product code	Height (in)	Length (in)	Packaging Pcs./Skid
5FBW12	5-1/8"	10-1/2"	720
5FBW16	5-1/8"	14-1/2"	540
5FBW24	5-1/8"	22-1/2"	360
10FBW12	10-1/4"	10-1/2"	720
10FBW16	10-1/4"	14-1/2"	540
10FBW24	10-1/4"	22-1/2"	360

U.S. Patent No. 7,882,676 of Jeffrey Thomas Ellis

D-Blaze® is a registered trademark of Viance, LLC

FlamePRO® is a registered trademark of Koppers Performance Chemicals, Inc.

#### FlamePRO® Fire Retardant complies with or has been granted the following:

- UL GREENGUARD Gold Certification – UL 2818
  - ICC ESR-4244
  - AWPA E12, AWPA M4, AWPA P50, AWPA T1 standard
  - Cal Fire Certified
  - American Institute of Architects Approved
  - ASTM 2768
  - ASTM D3201, D5516, D5664, E84, E119, 2768, D6305, D6841
  - AWPA T1
  - AWPA UC-1
  - Class A FRT wood
  - UL Recognized Component
  - NFPA 703, 101 Life Safety Code
  - City of Los Angeles Building Code
  - City of Los Angeles Residential Code
  - National Building Code of Canada
  - One & two hour tested wall assemblies
  - 50-year warranty
  - UL Classified with an FR-S Rating for flame spread and smoke development values of 25 or less
- (All are subject to revision, re-examination)

#### D-Blaze® Fire Retardant or D-Blaze® FRT Wood complies with or has been granted the following:

- ASTM E84
  - ASTM D3201
  - ASTM D5516
  - ASTM D5664
  - Underwriters Laboratories Classified
  - UL Class A (Class 1) with FR-S Rating CAN/ULC S102 & S102.2
  - GREENGUARD Gold Certified
  - National Fire Protection Association (NFPA 255)
  - City of Los Angeles Research Report: RR24502 in accordance with ICC-ES ESR 2645
  - New York City Building Code (MEA Numbers 406-87 and 407-87)
  - National Building Code of Canada
  - AWPA Standardized (P50, U1, UCFA) Interior Type A-High Temperature (HT) FRTW
  - California Department of Forestry and Fire Protection CSFM BML Listings for D-Blaze Plywood and Lumber
  - ICC-ES ESR-2645
  - 50-year warranty
- (All are subject to revision, re-examination)

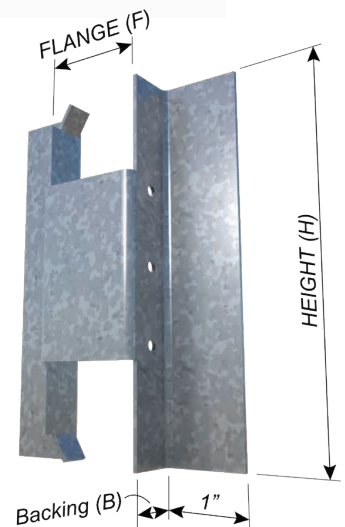

## Danback® Flexible Wood Backing Plate

### Reduces steel stud backing labor costs by up to 75%.

Danback® Flexible Wood Backing System, featuring D-Blaze® or FlamePRO® fire-retardant treated wood (FRT), has made wood backing installation easy and economical-eliminating cutting, notching, ripping and routing.

Danback provides superior connection shear and pullout strength to support and meet even some of the heaviest loading conditions. Simply snap, flex and screw Danback into place. The patented hinge design actually flexes around the stud and snaps into place for a perfect fit-every time.

- Provides extra screw pullout strength for heavy-duty backing applications
- Available in 48" sections, for either 16" or 24" o.c. framing
- Meets all specifications for commercial and residential applications

Perfect backing system for baseboards, door jams and wood trim, cabinets and vanities and ceiling and crown moldings.

The Evaluation Report Service found that the wood backing material complies with the requirements for fire retardant treated wood described in the International Building Codes (IBC & IRC).

Danback flexible wood backing is available with FSC®-certified lumber and may contribute LEED® points to your project.

### MATERIAL SPECIFICATIONS

**Material:** 3/4" CDX Doug Fir fire-retardant treated wood

**Dimensions:** 5-1/8" x 48" (130mm x 1219mm)

**Packaging:** (250) pieces per skid

**Product weight:** 5.114 lbs/piece

### Danback® Flexible Wood Backing Plates (D16, D24)

Product code	Width (in)	Length (in)	Spacing	Packaging Pcs./Skid
D16F*	5-1/8	48	16" o.c.	250
D24F*	5-1/8	48	24" o.c.	250
D16C**	5-1/8	48	16" o.c.	250
D24C**	5-1/8	48	24" o.c.	250

\*F = fire-treated plywood.

Trimables available for off-module spacing in bulk quantity.

\*\*FSC-certified lumber available on request, which can contribute to LEED® points on your project.

Contact ClarkDietrich LEED professionals at 888-437-3244 for more information.

FSC chain-of-custody # BV-COC-008121

### Load Tables

Installation condition	Nominal (lbs)
Shear / 0" Offset	2440
Shear / 1" Offset	825
Shear / 3" Offset	310
Tension	635

U.S. Patent Nos. 6,705,056 is owned by Kathy Tollenaar

Danback® is a trademark of Kathy Tollenaar

D-Blaze® is a registered trademark of Viance, LLC

FlamePRO® is a registered trademark of Koppers Performance Chemicals, Inc.

### Notes:

- Listed load values are nominal test load values, appropriate safety factors/resistance factors should be applied by the designer for calculating loads for intended use.
- Shear / Offset (moment-rotation) Load refers to load directed in the plane of the wall.
- Tension Load refers to load directed perpendicular to wall or plywood surface.
- Tabulated loads include the contribution of 5/8" gypsum board.
- Test loads were applied to the gypsum board and backing system through a 1/2" thick, 2-3/4" diameter steel plate secured with (4) #12 hex head screws.
- Loads were applied directly through the steel plate or to a steel rod that cantilevered from the plate.
- Typical failure mode in backing testing was the gypsum board failure.
- 24-in o.c. stud spacing test results were similar/identical to 16-in o.c. test results.
- Listed nominal capacities are based on using 33mils (20ga) non-structural framing members/studs.
- Anchor to the stud flange using (3) #8 wafer head/pan head screws.

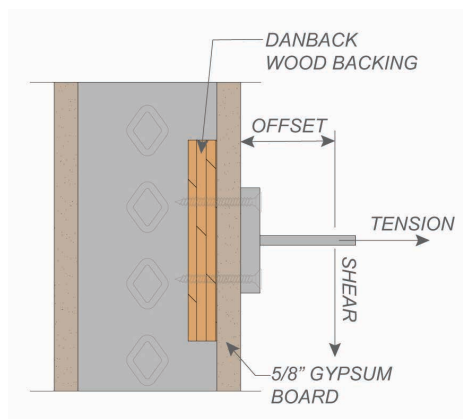



## Easy installation.



Snap starter edge into the open side of the stud flange.



**HINT:** Start with the first full bay. Use Danback trimmables for off-module bays.



Flex Danback flexible wood backing around stud flange using the flexible connector plate.



Repeat the process.



Overlap connector plates when using in long backing runs.



Secure each plate to the stud flange using three small pan or wafer-head screws.

Commonly used in: hospitals, medical centers, schools, hotels/motels, assisted living, condominiums, and others. The perfect backing solution for: cabinets, shelves, counters, sinks, handrails, chalkboards, towel and shower bars, or other wall-mounted fixtures that require heavy-duty backing.



## Use Danback trimmables for off-module bays:



Danback trimmables for off-module backing.

Cut to required length. Secure connector plate to the trimmed edge. Leave 1-1/4" extended over the trimmed edge. Fasten the plate to Danback using three small pan or wafer-head screws.

Connector plates included with trimmables.

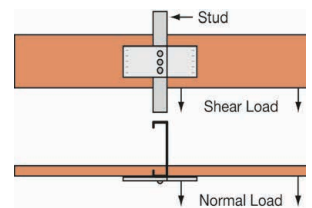

### FlamePRO® Fire Retardant complies with or has been granted the following:

- UL GREENGUARD Gold Certification – UL 2818
- ICC ESR-4244
- AWPA E12, AWPA M4, AWPA P50, AWPA T1 standard
- Cal Fire Certified
- American Institute of Architects Approved
- ASTM 2768
- ASTM D3201, D5516, D5664, E84, E119, 2768, D6305, D6841
- AWPA T1
- AWPA UC-1
- Class A FRT wood
- UL Recognized Component
- NFPA 703, 101 Life Safety Code
- City of Los Angeles Building Code
- City of Los Angeles Residential Code
- National Building Code of Canada
- One & two hour tested wall assemblies
- 50-year warranty
- UL Classified with an FR-S Rating for flame spread and smoke development values of 25 or less (All are subject to revision, re-examination)

### D-Blaze® Fire Retardant or D-Blaze® FRT Wood complies with or has been granted the following:

- ASTM E84
- ASTM D3201
- ASTM D5516
- ASTM D5664
- Underwriters Laboratories Classified
- UL Class A (Class 1) with FR-S Rating CAN/ULC S102 & S102.2
- GREENGUARD Gold Certified
- National Fire Protection Association (NFPA 255)
- City of Los Angeles Research Report: RR24502 in accordance with ICC-ES ESR 2645
- New York City Building Code (MEA Numbers 406-87 and 407-87)
- National Building Code of Canada
- AWPA Standardized (P50, U1, UCFA) Interior Type A-High Temperature (HT) FRTW
- California Department of Forestry and Fire Protection CSFM BML Listings for D-Blaze Plywood and Lumber
- ICC-ES ESR-2645
- 50-year warranty (All are subject to revision, re-examination)

## Backer Bar

Provides superior connection shear and pullout strength for handrails, shelves and other wall fixtures

The Backer Bar was specifically designed to meet the demand for the attachment of multiple items and heavier items to interior partitions.

Today's building professionals require solutions to allow the attachment of such products and accessories to the interior partition walls. Traditionally, backing systems have been costly, time-consuming and not necessarily performing to the required code specified load requirements. Backer Bar is designed for use on non-structural and structural studs.

### TYPICAL APPLICATIONS:

- Wall-Mounted Televisions
- Hospital Handrails
- Towel and Shower Bars
- Cabinets and Shelves

### FEATURES AND BENEFITS:

- Installs quickly and easily
- Available in 12", 16" and 24" spacing
- For use on non-structural and structural studs

Canada Patent Pending – 2,811,362

USA Patent – 9,062,455

### PRODUCT DIMENSIONS

Leg: 1-1/4"

Width: 5"

Lengths: For 12", 16" and 24" o.c. stud spacing

### MATERIAL SPECIFICATIONS

Gauge: 20 gauge STR (33mils)

Design Thickness: 0.0346 inches

Coating: G90

Material: Grade 50ksi min. yield strength

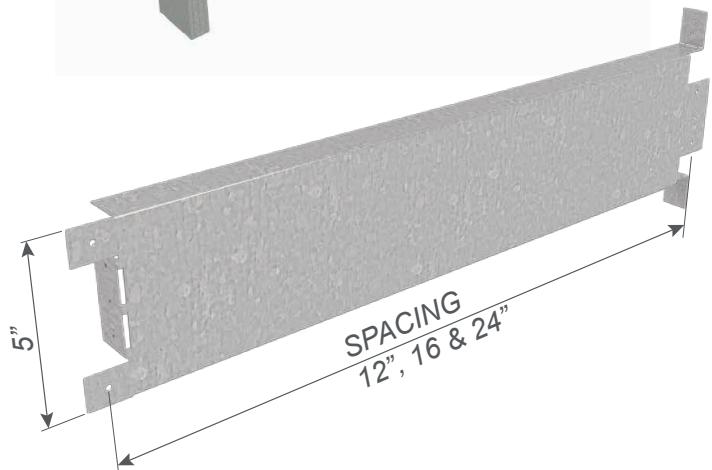
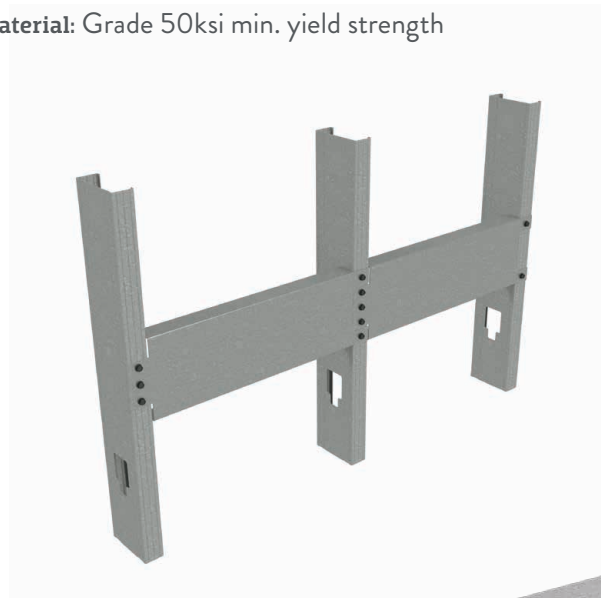

## Backer Bar (BB12, BB16, BB24)

Product code	Thickness		Size (in)	Packaging
	Mils (Gauge)	Design thickness (in)		
BB12	33mils (20ga)	0.0346	1-1/4" x 5" x 12"	Individual
BB16	33mils (20ga)	0.0346	1-1/4" x 5" x 16"	
BB24	33mils (20ga)	0.0346	1-1/4" x 5" x 24"	

## BlazeFrame® Shield

### 33mils, 43mils or 54mils fire shield system

ClarkDietrich's BlazeFrame Shield is specifically designed for use in conjunction with approved fireblocking materials per section 718 of the IBC. BlazeFrame Shield simply installs by twisting into stud flanges and screwing into stud webs. The one piece preformed assembly eliminates cutting, notching and attaching clips.

- Installs quickly and easily without clips
- Available for 16" and 24" stud spacing
- Three available widths
- Available in 33mils (20ga), 43mils (18ga) or 54mils (16ga)
- Pre-notched for use on structural studs (1-5/8" flange only)

### PRODUCT DIMENSIONS

Horizontal leg: 1"

Connection Tabs: Top: 2", Bottom: 1-1/2"

Width: 3-5/8", 4" or 6"

Lengths: For 16" and 24" o.c. stud spacing

### MATERIAL SPECIFICATIONS

**Gauge:** 20 gauge STR (33mils)

**Design Thickness:** 0.0346 inches

**Gauge:** 18 gauge (43mils)

**Design Thickness:** 0.0451 inches

**Gauge:** 16 gauge (54mils)

**Design Thickness:** 0.0566 inches

**Coating:** CP60

**Yield Strength:** 33ksi for 33mils & 43mils  
50ksi for 54mils

**ASTM:** C955, A1003

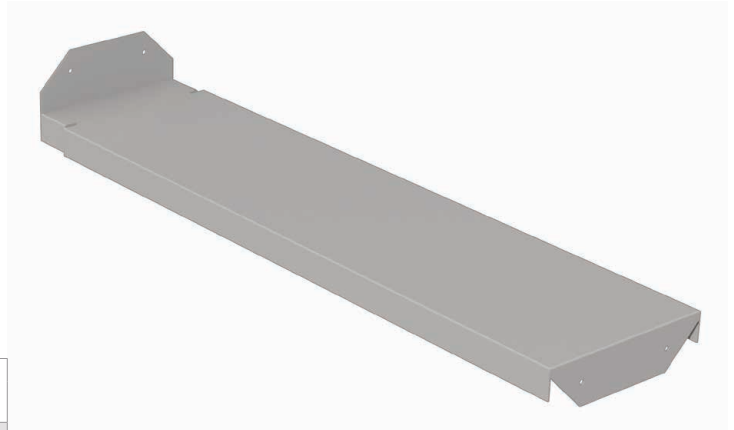

## BlazeFrame® Shield

Product code	Thickness		Size (in)
	Mils (Gauge)	Design thickness (in)	
FS316-33	33mils (20ga)	0.0346	3-5/8" web 16" o.c.
FS316-43	43mils (18ga)	0.0451	3-5/8" web 16" o.c.
FS316-54	54mils (16ga)	0.0566	3-5/8" web 16" o.c.
FS324-33	33mils (20ga)	0.0346	3-5/8" web 24" o.c.
FS324-43	43mils (18ga)	0.0451	3-5/8" web 24" o.c.
FS324-54	54mils (16ga)	0.0566	3-5/8" web 24" o.c.
FS416-33	33mils (20ga)	0.0346	4" web 16" o.c.
FS416-43	43mils (18ga)	0.0451	4" web 16" o.c.
FS416-54	54mils (16ga)	0.0566	4" web 16" o.c.
FS424-33	33mils (20ga)	0.0346	4" web 24" o.c.
FS424-43	43mils (18ga)	0.0451	4" web 24" o.c.
FS424-54	54mils (16ga)	0.0566	4" web 24" o.c.
FS616-33	33mils (20ga)	0.0346	6" web 16" o.c.
FS616-43	43mils (18ga)	0.0451	6" web 16" o.c.
FS616-54	54mils (16ga)	0.0566	6" web 16" o.c.
FS624-33	33mils (20ga)	0.0346	6" web 24" o.c.
FS624-43	43mils (18ga)	0.0451	6" web 24" o.c.
FS624-54	54mils (16ga)	0.0566	6" web 24" o.c.



## 2x6 FR Blocking

### Fire-retardant treated wood blocking for non-structural steel framing

2x6 fire-retardant treated wood blocking for non-structural steel framing with dado groove to latch on to flanges and span between wall partitions to provide attachment surface for wall mounted fixtures.

2x6 FR Blocking is fire-retardant, pressure-treated wood that is chemically treated to reduce flamespread and smoke development. Fire-retardant wood complies with national building codes, including the International Building Code (IBC) and the International Residential Code (IRC).

D-Blaze® is a registered trademark of Viance, LLC.

#### PRODUCT DIMENSIONS

Size: 1-1/2" x 5-1/2" x 15-3/4"

#### FEATURES AND BENEFITS:

- D-Blaze® Fire-Retardant Treatment
- Constructed from Southern Yellow Pine (SYP)
- Dado groove provides secure and flush mounting surface
- Pre-cut for 16" o.c. spacing
- Provides reinforcement to the structural integrity of the walls for stability of wall-mounted fixtures
- 50 year warranty



### 2x6 FR Blocking (FRB26-16)

Product code	Thickness	Height	Length	Pcs./Skid
FRB26-16	1-1/2"	5-1/2"	15-3/4"	288

Material: Southern Yellow Pine (SYP) treated with D-Blaze® fire-retardant treatment

Product weight: 2.35 lbs. / piece

## INSTALLATION

Secure wood blocking into place using stainless steel or hot-dip galvanized fasteners. On one side, insert fasteners through the stud flange and into the face of the blocking and for the other side insert fasteners through the stud web and into the butt end of the blocking.

**D-Blaze® Fire Retardant or D-Blaze® FRT Wood complies with or has been granted the following:**

- ASTM E84
  - ASTM D3201
  - ASTM D5516
  - ASTM D5664
  - Underwriters Laboratories Classified
  - UL Class A (Class 1) with FR-S Rating CAN/ULC S102 & S102.2
  - UL GREENGUARD Gold Certified - UL 2818
  - National Fire Protection Association (NFPA 255)
  - City of Los Angeles Research Report: RR24502 in accordance with ICC-ES ESR 2645
  - New York City Building Code (MEA Numbers 406-87 and 407-87)
  - National Building Code of Canada
  - AWWA Standardized (P50, U1, UCFA) Interior Type A-High Temperature (HT) FRTW
  - California Department of Forestry and Fire Protection CSFM BML Listings for D-Blaze Lumber
  - Class FRT Lumber
  - 50-year warranty
- (All are subject to revision, re-examination)

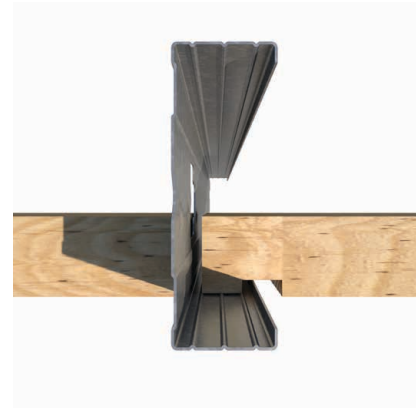
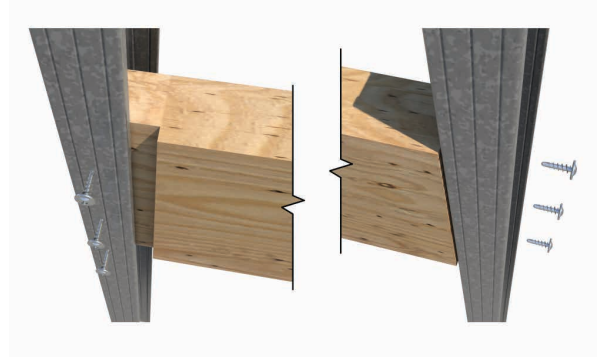

## Product Detail

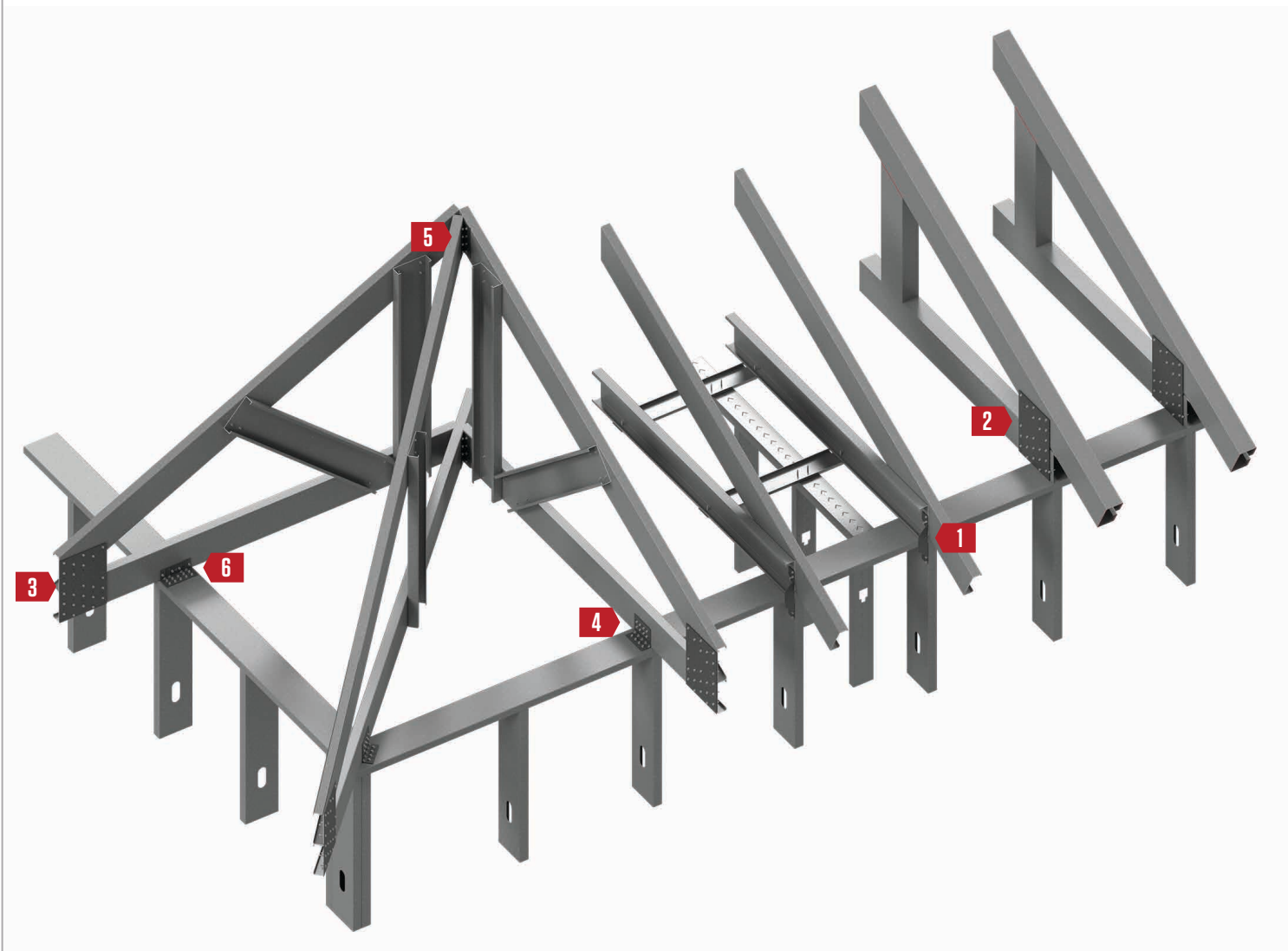

**1** ClarkDietrich Seismic and Hurricane Clips  
pages 164-165

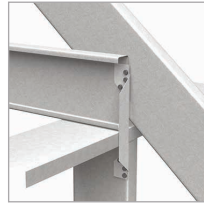
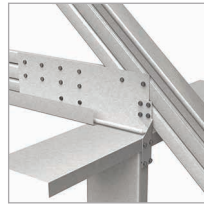

**2** GP-Series™ Unpunched Gusset Plate  
pages 166-167

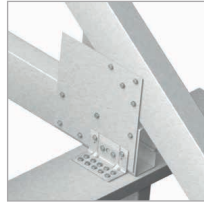
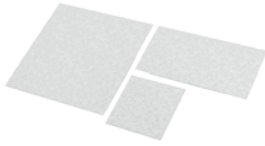

**3** G-Series™ Punched Gusset Plate  
pages 168-169

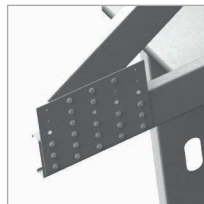
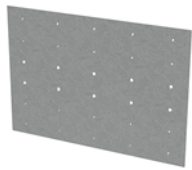

**4** Uni-Clip End Clip  
pages 74-75

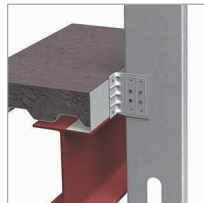
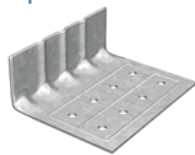

**5** Skewable Angle  
page 128-129



**6** EasyClip D&T-Series™ Anchor Clips  
pages 94-95

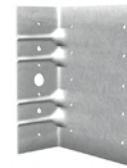
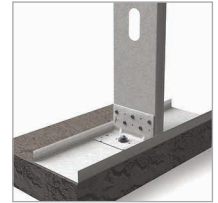
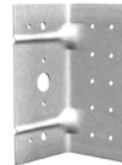

## Seismic and Hurricane Ties

Attach and secures trusses and rafters to the building structure.

ClarkDietrich seismic and hurricane ties are designed to provide wind and seismic resistance for trusses and rafters. Quick and efficient, these versatile connectors can also be used for general tie-down purposes, strong back attachments and as all-purpose ties where one member crosses another. The HC2 and HC2A seismic and hurricane ties are formed from a flat plate into an A-shaped section. The plate has a right-angle bend along its longitudinal axis to permit straddling a top plate. The HC2.5 and HC3 are twisted strap ties that are used to attach a rafter to the side of the top plate.

### ALTERNATIVE PRODUCTS

EasyClip™ T-Series™ Tall Anchor Clip  
 EasyClip E-Series™ Support Clip

### MATERIAL SPECIFICATIONS

**Gauge:** 18 gauge (43mils)

**Design Thickness:** 0.0451 inches

**Coating:** G90

**Yield Strength:** 50ksi

**ASTM:** A653/A653M

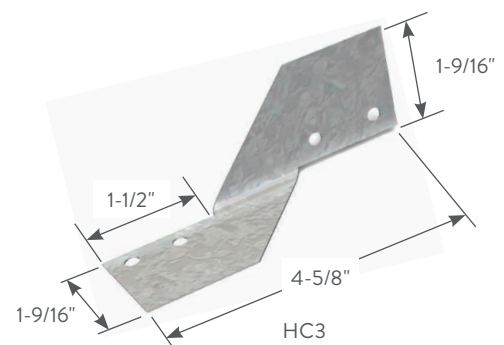
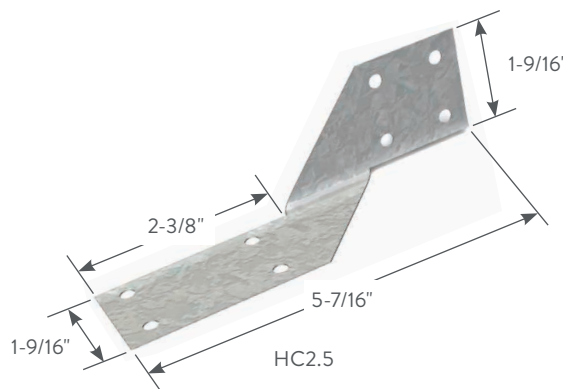
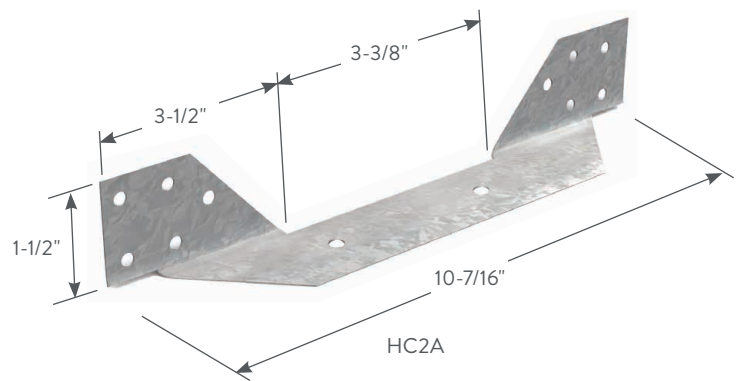
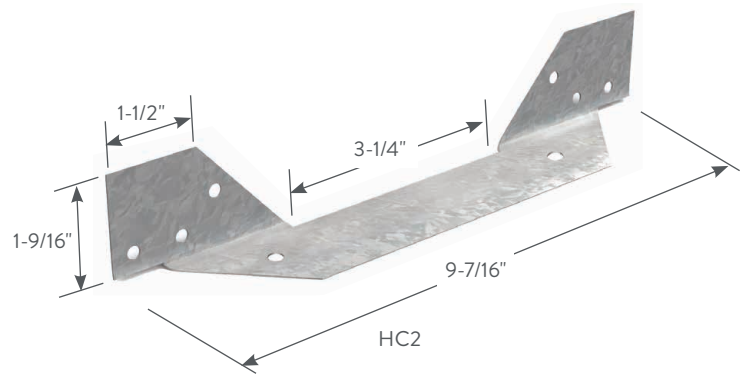

### ClarkDietrich Seismic and Hurricane Ties

Product code	Thickness		Size (in)	Packaging Pcs./Carton
	Mils (Gauge)	Design thickness (in)		
HC2	43mils (18ga)	0.0451	1-9/16 x 9-7/16 x 1-9/16	100
HC2A	43mils (18ga)	0.0451	1-1/2 x 10-7/16 x 1-1/2	100
HC2.5	43mils (18ga)	0.0451	1-9/16 x 5-7/16 x 1-9/16	100
HC3	43mils (18ga)	0.0451	1-9/16 x 4-5/8 x 1-9/16	100



**HC2 OR HC2A INSTALLATION**

Place the tie so one end fits flush against the roof framing member and the other fits flush against the web of the wall stud. Attach the tie to the side of the rafter at the top and to the sides of the stud immediately below the top plate at the bottom. Fill all prepunched holes with a minimum of #10 self-drilling screws.

**HC2.5 OR HC3 INSTALLATION**

Place the tie so the top fits securely against the roof framing member and the bottom fits securely against the top plate and flange of the wall stud. Attach the tie to the rafter at the top and to the sides of the top plate and stud immediately below. Fill all prepunched holes with a minimum #10 self-drilling screws.

Reference section R 603.8.3.2 of the International Residential Code (IRC) or the engineer of records specification.

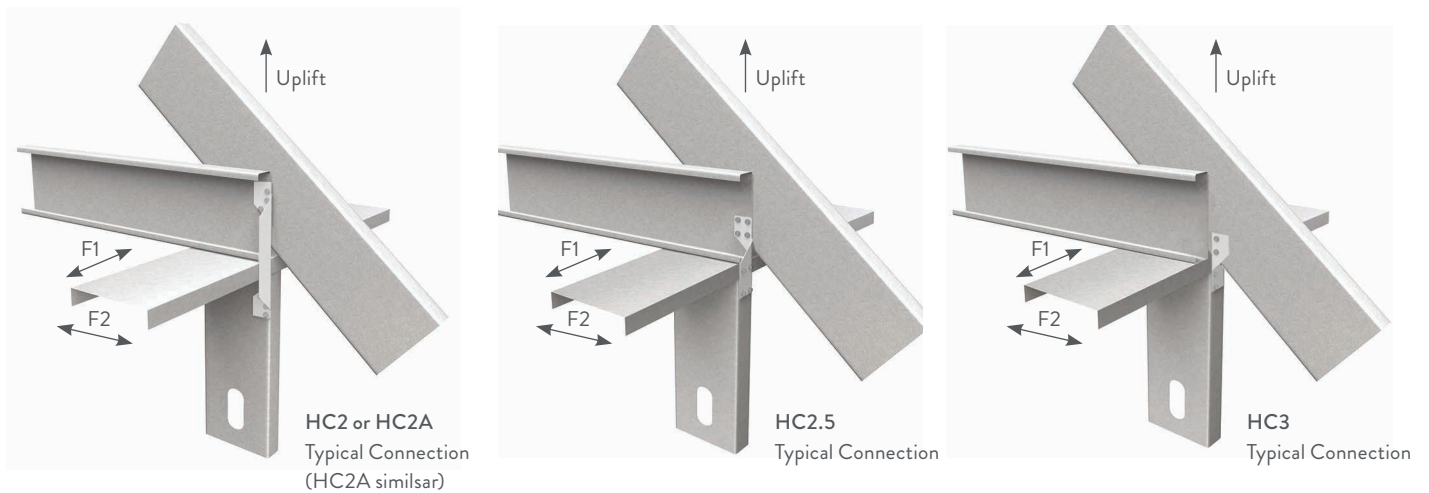

Typical Construction Details  
 Visit our CAD Library at [clarkdietrich.com](http://clarkdietrich.com) to view or download construction details in .dwg, .dxf, and .pdf formats.

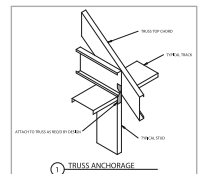

**ClarkDietrich Seismic and Hurricane Ties**

Product code	Fasteners			Stud thickness Mils (Gauge)	Yield Strength (ksi)	Max. Allowable Loads		
	To rafters / truss	To top track	To stud			Uplift	Lateral	
							F1	F2
HC2	3 - #10	-	3 - #10	33mils (20ga)	33ksi	405	-	-
				43mils (18ga)	33ksi	445	-	-
				54mils (16ga)	50ksi	465	-	-
	3 - #10	1 - #10	3 - #10	33mils (20ga)	33ksi	405	90	120
				43mils (18ga)	33ksi	445	110	170
				54mils (16ga)	50ksi	465	110	225
HC2A	3 - #10	1 - #10	3 - #10	33mils (20ga)	33ksi	405	90	120
				43mils (18ga)	33ksi	445	110	170
				54mils (16ga)	50ksi	465	110	225
HC2.5	4 - #10	-	4 - #10	33mils (20ga)	33ksi	410	90	120
				43mils (18ga)	33ksi	475	140	170
				54mils (16ga)	50ksi	475	140	225
HC3	2 - #10	2 - #10*	-	33mils (20ga)	33ksi	340	80	80
				43mils (18ga)	33ksi	465	110	140
				54mils (16ga)	50ksi	475	110	195

**Notes:**

- 1 Loads have been increased for wind or earthquake loading.
- \* Fasteners to top track must also penetrate.

## GP-Series™ Unpunched Gusset Plate

Use in conjunction with X-bracing in load-bearing shearwall assemblies to resist racking under wind and seismic loads.

Gusset plates and diagonal tension strapping components are used in combination to provide shearwall (racking restraint) for light-gauge, load-bearing framing under wind and seismic loads. Resisting uplift and shear forces, they are normally installed on both sides of the wall directly over the framing members.

**CAUTION:** Racking loads are first transferred to the roof or floor decking and then to the shearwalls (X-bracing). The X-bracing then relies on a proper anchorage to the foundation to resist uplift and shear forces. In order for the system to function properly, the load path from the roof or floor deck to the shearwalls to the foundation must be complete. This normally requires additional bracing, blocking, track and rim splices, drag struts, uplift anchors and heavy-duty foundations.

### PRODUCT DIMENSIONS

6" x 6"

6" x 12"

12" x 12"

Custom sizes, shapes, and gauges available.

### MATERIAL SPECIFICATIONS

**Gauge:** 16 gauge (54mils)

**Design Thickness:** 0.0566 inches

**Gauge:** 14 gauge (68mils)

**Design Thickness:** 0.0713 inches

**Gauge:** 12 gauge (97mils)

**Design Thickness:** 0.1017 inches

**Coating:** G90

**Yield Strength:** 50ksi

**ASTM:** A653/A653M

### INSTALLATION

Straps are positioned diagonally from the bottom track to the top track. In order to resist load in each direction, an X-configuration should be used. At a minimum, double studs are positioned at ends of the X-brace to serve as compression studs. Straps are either attached directly to the compression studs or are attached via gusset plates. Compression studs must be anchored to the foundation, normally with uplift anchors. For multi-story construction, the uplift loads can be extremely high. It is recommended that the services of a qualified professional engineer be used to verify the applicability of the system selected.

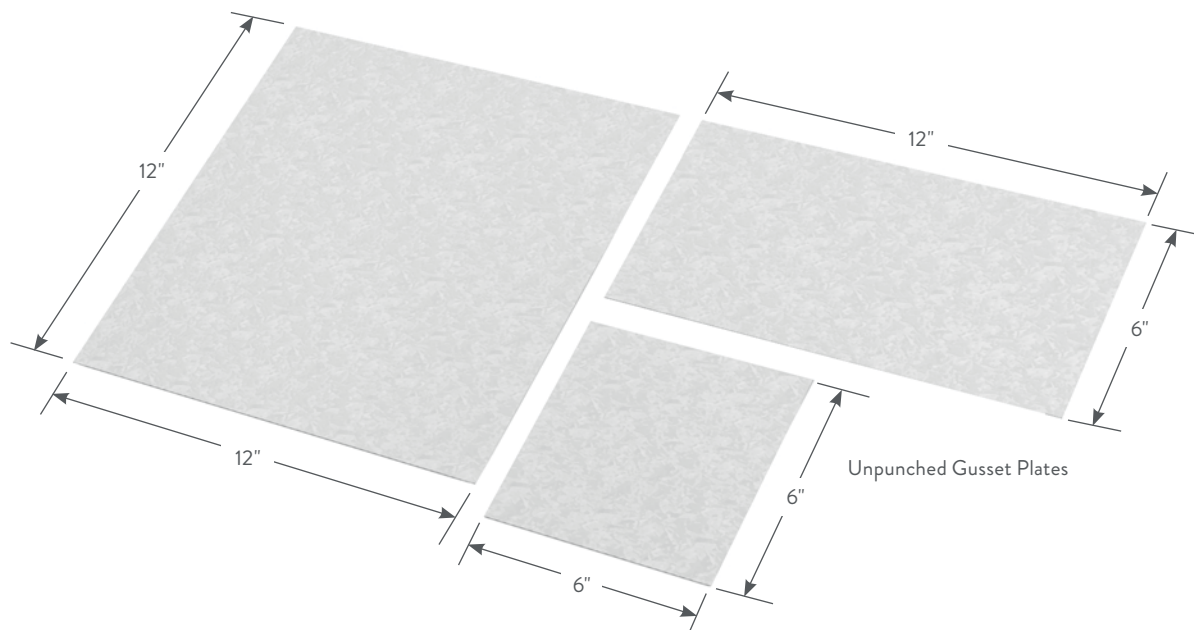

Unpunched Gusset Plates for ShearWall Bracing				
Product code	Thickness		Plate size (in)	Packaging Pcs.
	Mils (Gauge)	Design thickness (in)		
GP	54mils (16ga)	0.0566	6 x 6	25
			6 x 12	25
			12 x 12	25
	97mils (12ga)	0.1017	6 x 6	25
			6 x 12	25
			12 x 12	25



GP-Series unpunched gusset plates are also used to facilitate connections between chord members for in-plane framing.

TYPICAL CONSTRUCTION DETAILS

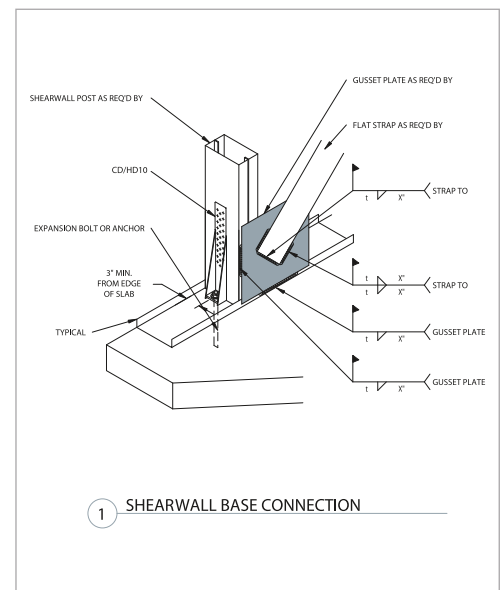
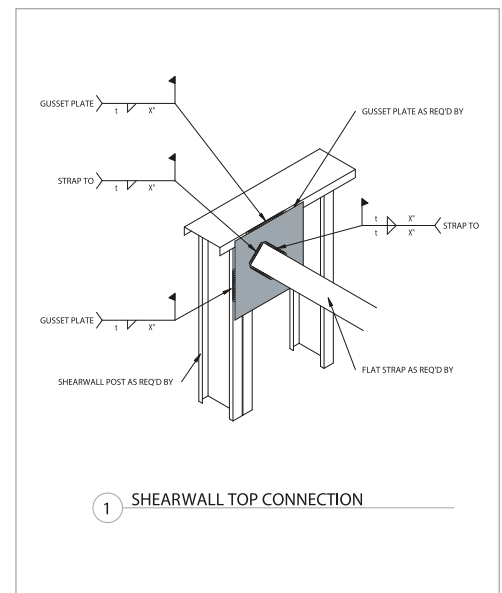

Visit our CAD Library at [clarkdietrich.com](http://clarkdietrich.com) to view or download construction details in .dwg, .dxf, and .pdf formats.

## G-Series™ Punched Gusset Plate

A multipurpose connector used for a variety of framing connections.

G-Series™ punched gusset plates come with multi-hole shapes for proper fastening to achieve desired performance. Used in a variety of framing connections—including roof framing, header framing and shearwall applications—the gusset plates eliminate angled cutting. Prepunched for easier, faster attachments, the gusset plates adapt to multiple configurations and varying construction tolerances.

**CAUTION:** Racking loads are first transferred to the roof or floor decking and then to the shearwalls (X-bracing). The X-bracing then relies on a proper anchorage to the foundation to resist uplift and shear forces. In order for the system to function properly, the load path from the roof or floor deck to the shearwalls to the foundation must be complete. This normally requires additional bracing, blocking, track and rim splices, drag struts, uplift anchors and heavy-duty foundations.

### PRODUCT DIMENSIONS

6" x 8-1/2"

### MATERIAL SPECIFICATIONS

**Gauge:** 18 gauge (43mils)

**Design Thickness:** 0.0451 inches

**Gauge:** 16 gauge (54mils)

**Design Thickness:** 0.0566 inches

**Gauge:** 14 gauge (68mils)

**Design Thickness:** 0.0713 inches

**Coating:** G90

**Yield Strength:** 33ksi for 18 gauge

50ksi for 14 & 16 gauge

**ASTM:** A653/A653M

### INSTALLATION

Straps are positioned diagonally from the bottom track to the top track. In order to resist load in each direction, an X-configuration should be used. At a minimum, double studs are positioned at ends of the X-brace to serve as compression studs. Straps are either attached directly to the compression studs or are attached via gusset plates. Compression studs must be anchored to the foundation, normally with ClarkDietrich holdowns. For multi-story construction, the uplift loads can be extremely high. It is recommended that the services of a qualified professional engineer be used to verify the applicability of the system selected.

### G-Series™ Punched Gusset Plates

Product code	Thickness		Size (in)	Packaging Pcs./Bucket
	Mils (Gauge)	Design thickness (in)		
G436	43mils (18ga)	0.0451	6 x 8-1/2	50
G546	54mils (16ga)	0.0566	6 x 8-1/2	50
G686	68mils (14ga)	0.0713	6 x 8-1/2	50

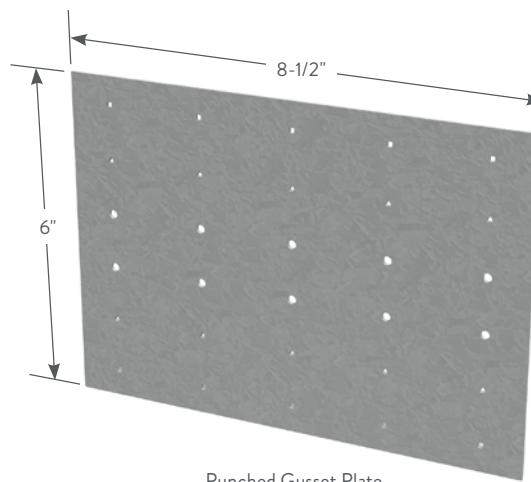

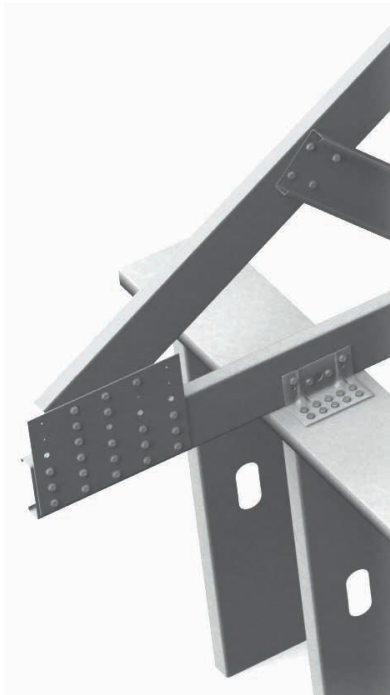

TYPICAL CONSTRUCTION DETAILS

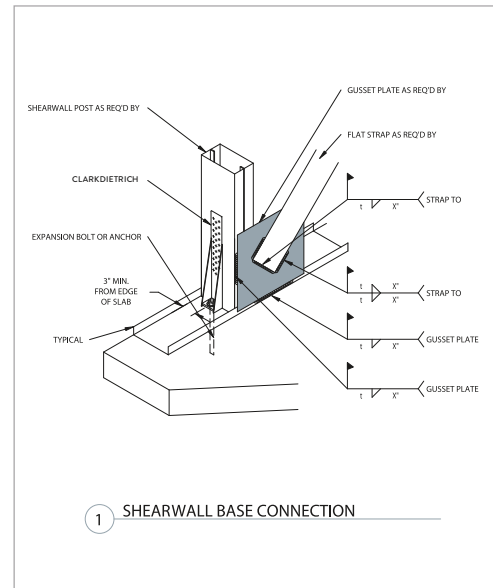
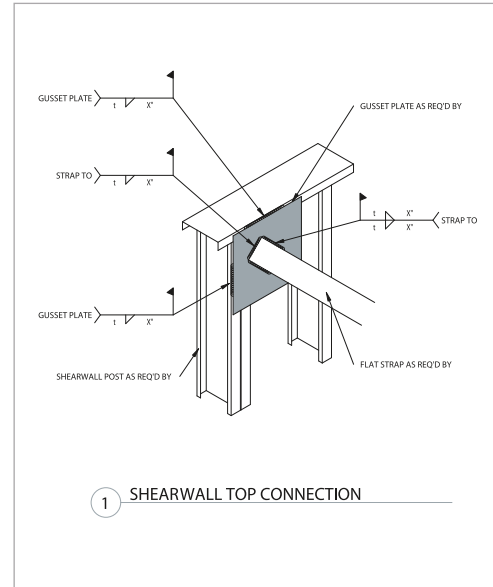

Visit our CAD Library at [clarkdietrich.com](http://clarkdietrich.com) to view or download construction details in .dwg, .dxf, and .pdf formats.

Product Detail

**1 HDSC Header Bracket for RedHeader PRO™**  
pages 172–175

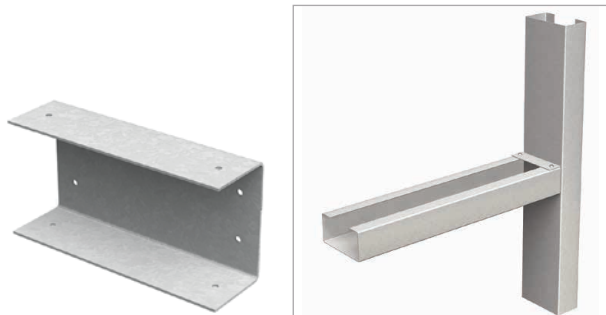

**4 ClarkDietrich Sound Clip**  
page 178-183

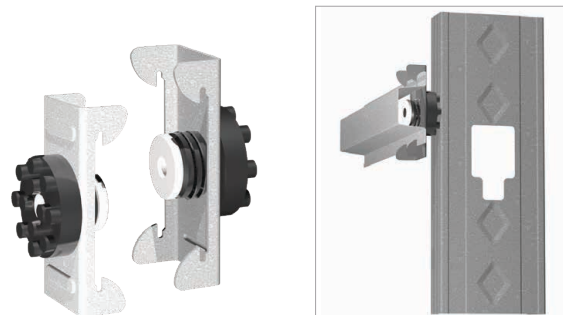

**2 Aluminum Burn Clip**  
page 176

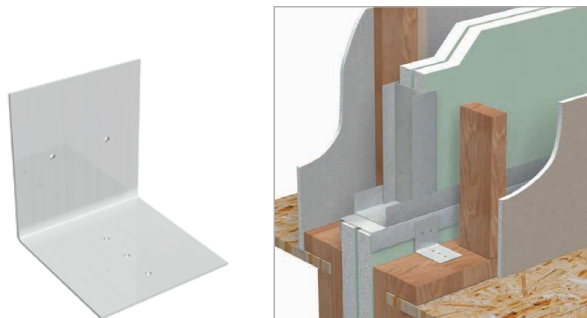

**5 Header Cripple Stud Clip**  
page 184



**3 Grommets for Stud Knockouts**  
page 177



**6 Metal Furring Channel Clip**  
page 185

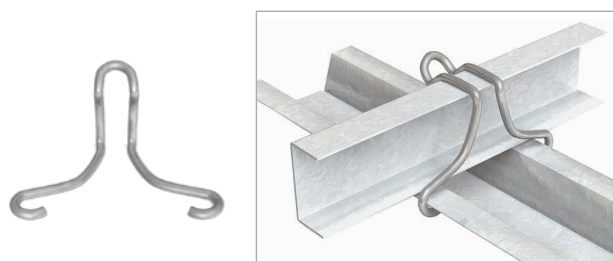

**7 Panel Lift Clip**  
pages 186-187

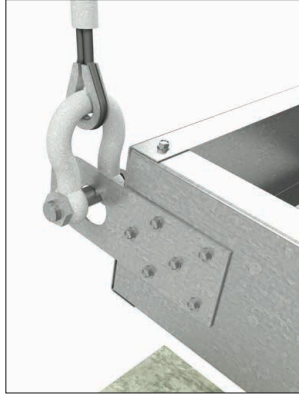

**8 Commercial Strapping**  
pages 188-189

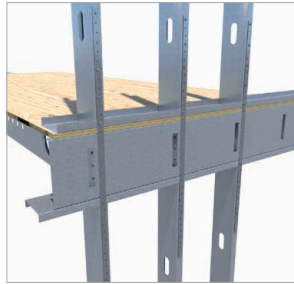
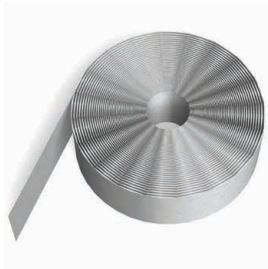

**8 Box Header Clip**  
pages 190-191



## HDSC Header Bracket

For use with the RedHeader PRO™ and HDS® Rough Opening Systems.

The HDSC Header Bracket is the perfect complement to the RedHeader PRO™ Framing system and HDS® Framing System. This simple, yet innovative header bracket turns curtain-wall header installation from a two-person job into a one-person job. This unique, pre-punched clip also eliminates surface head fastener buildup that can create finishing challenges. The HDSC is sized to be used with either 3" or 3-1/2" flanged member.

### PRODUCT DIMENSIONS

3-1/2" x 3-1/16" x 2"	3-1/2" x 3-9/16" x 2"
3-7/8" x 3-1/16" x 2"	3-7/8" x 3-9/16" x 2"
5-7/8" x 3-1/16" x 2"	5-7/8" x 3-9/16" x 2"
7-7/8" x 3-1/16" x 2"	7-7/8" x 3-9/16" x 2"

### MATERIAL SPECIFICATIONS

**Gauge:** 20 gauge (33mils)

**Design Thickness:** 0.0346 inches

**Yield Strength:** 33ksi

**Gauge:** 14 gauge (68mils)

**Design Thickness:** 0.0713 inches

**Yield Strength:** 50ksi

**Gauge:** 12 gauge (97mils)

**Design Thickness:** 0.1017 inches

**Yield Strength:** 50ksi

**Coating:** G90

**ASTM:** A653/A653M, A1003/A1003M

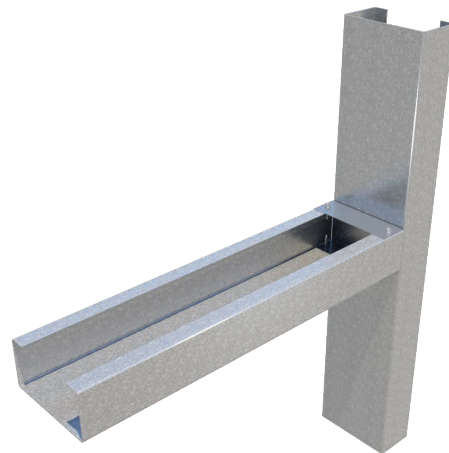
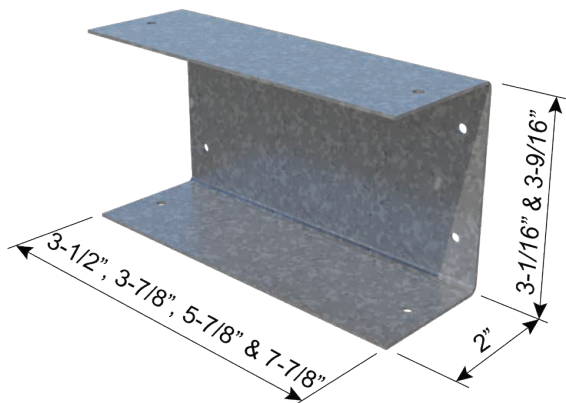
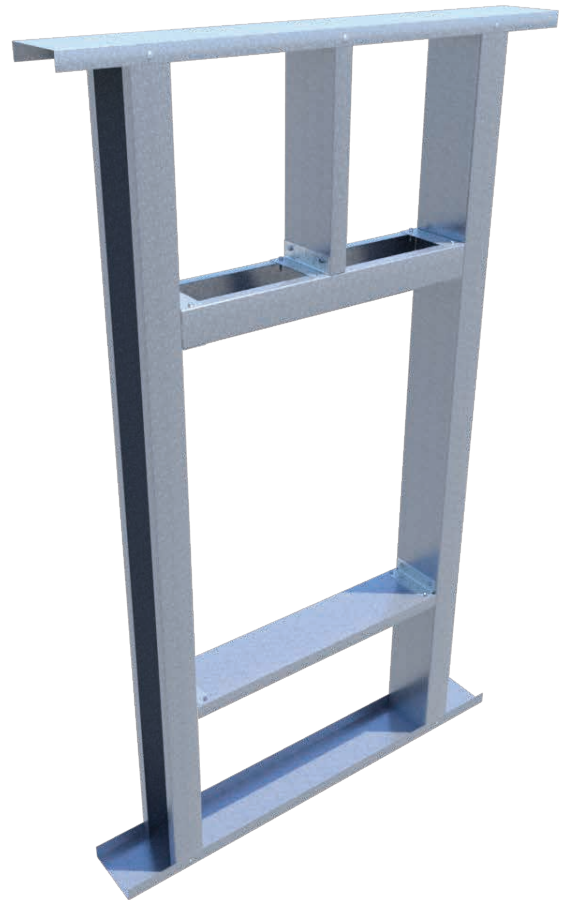





### HDSC 33mils (20ga) Header Brackets (3" & 3-1/2" Flange)

Product Code	Bracket Specs		Framing Member Specs		Designed to Support
	Depth (D)	Height (H)	Thickness Mils (Gauge)	Yield Strength, Fy (ksi)	
350HDSC300-33	3-1/2"	3"	33 (20)	33	3-5/8" RedHeader or HDS with 3" Flange
350HDSC350-33		3-1/2"			3-5/8" RedHeader with 3-1/2" Flange
387HDSC300-33	3-7/8"	3"	33 (20)	33	4" RedHeader or HDS with 3" Flange
387HDSC350-33		3-1/2"			4" RedHeader with 3-1/2" Flange
587HDSC300-33	5-7/8"	3"	33 (20)	33	6" RedHeader or HDS with 3" Flange
587HDSC350-33		3-1/2"			6" RedHeader with 3-1/2" Flange
787HDSC300-33	7-7/8"	3"	33 (20)	33	8" RedHeader or HDS with 3" Flange
787HDSC350-33		3-1/2"			8" RedHeader with 3-1/2" Flange

All material G90. Sold in pairs.

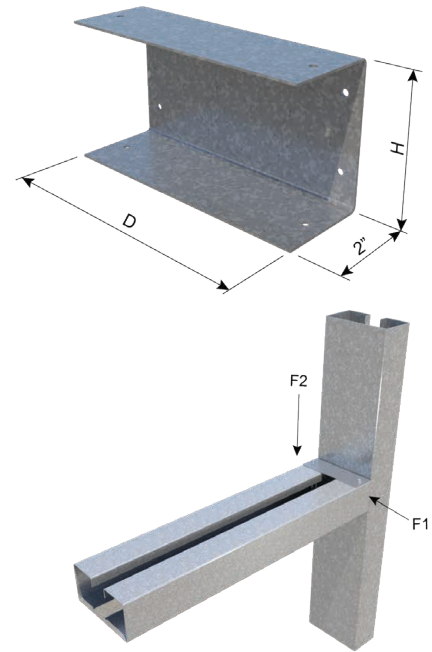

### Allowable Loads (lbs) for 3" & 3-1/2" Flange Header Systems

Product Code	Bracket Specs		Framing Member Specs		Fasteners		Capacities (lbs)					
	Depth (D)	Height (H)	Thickness Mils (Gauge)	Yield Strength, Fy (ksi)	Jamb	Header	F1 Load (Lateral)			F2 Load (Vertical)		
							Nominal (lbs)	ASD Load (lbs)	LRFD Load (lbs)	Nominal (lbs)	ASD Load (lbs)	LRFD Load (lbs)
350HDSC300-33	3-1/2"	3"	33 (20)	33	4 x #10	4 x #10	1200	615	985	895	190	190
			43 (18)	33			1435	735	1180	1555	245	245
			54 (16)	50			2000	1025	1595	2540	300	300
			68 (14)	50			2290	1060	1595	1435	425	425
			97 (12)	50			2875	1060	1595	1750	450	450
350HDSC350-33	3-1/2"	3-1/2"	54 (16)	50	4 x #10	4 x #10	2095	1060	1595	1020	380	380
			68 (14)	50			2460	1060	1595	1280	395	395
			97 (12)	50			2675	1060	1595	1765	460	460
			33 (20)	33			1090	560	895	1110	220	220
387HDSC300-33	3-7/8"	3"	43 (18)	33	4 x #10	4 x #10	1420	730	1165	1585	280	280
			54 (16)	50			2085	1060	1595	2130	310	310
			68 (14)	50			2290	1060	1595	1435	425	425
			97 (12)	50			2875	1060	1595	1750	450	450
			54 (16)	50			2095	1060	1595	1020	380	380
387HDSC350-33	3-7/8"	3-1/2"	68 (14)	50	4 x #10	4 x #10	2460	1060	1595	1280	395	395
			97 (12)	50			2560	1060	1595	1935	455	455
			33 (20)	33			1150	590	945	1050	205	205
			43 (18)	33			1410	720	1155	1765	320	320
587HDSC300-33	5-7/8"	3"	54 (16)	50	4 x #10	4 x #10	2085	1060	1595	2130	320	320
			68 (14)	50			2290	1060	1595	1435	425	425
			97 (12)	50			2875	1060	1595	1750	450	450
			54 (16)	50			2095	1060	1595	1020	380	380
			68 (14)	50			2460	1060	1595	1280	395	395
587HDSC350-33	5-7/8"	3-1/2"	97 (12)	50	4 x #10	4 x #10	2560	1060	1595	1935	455	455
			33 (20)	33			1210	620	995	990	190	190
			43 (18)	33			1540	790	1265	1630	270	270
			54 (16)	50			2045	1050	1595	2130	310	310
787HDSC300-33	7-7/8"	3"	68 (14)	50	4 x #10	4 x #10	2195	1060	1595	1395	385	385
			97 (12)	50			2875	1060	1595	1750	450	450
			54 (16)	50			2030	1040	1595	1075	320	320
			68 (14)	50			2460	1060	1595	1280	395	395
			97 (12)	50			2450	1060	1595	2105	455	455

**Notes:**

- Listed Capacities were derived from calculations and structural tests in accordance with provisions of AISI S100 and ICC-ES AC261.
- The safety factor for ASD loads and resistance factor for LRFD loads are calculated in accordance with Chapter K.
- The capacity of a given HDSC connection is the minimum of the corresponding jamb and the header values. For example, for a 3-1/2" HDSC-33 bracket (3" Flange) used with a 54mils (16ga) 50 ksi jamb and a 97mils (12ga) 50 ksi header, the F2 allowable design load shall be the capacity corresponding to framing member with lesser thickness i.e., 16ga member. Thus, the ASD capacity is 300 lbs.
- #10-16 HWH Screws by ITW Buildex were used to attach Brackets to Jamb and Header. The screws shall have a minimum shear capacity of 1400 lbs and minimum tension capacity of 1158 lbs. Evidence shall be provided to the building official for approval that defines the fasteners meet the performance requirements of this report, ASTM C1513 and are for use with cold-formed steel.
- For simultaneous F1 and F2 loading, use the following interaction equation:  $(F1/F1)^2 + (F2/F2)^2 \leq 1.0$  Where f1 and f2 are the applied loads and F1 and F2 are the appropriate allowable loads.
- It is the responsibility of the design professional to detail the project drawings for proper HDSC bracket installation.

## HDSC Header Bracket

### HDSC 68mils (14ga) Header Brackets (3" & 3-1/2" Flange)

Product Code	Bracket Specs		Framing Member Specs		Designed to Support
	Depth (D)	Height (H)	Thickness Mils (Gauge)	Yield Strength, Fy (ksi)	
350HDSC300-68	3-1/2"	3"	68 (14)	50	3-5/8" RedHeader or HDS with 3" Flange
350HDSC350-68		3-1/2"			3-5/8" RedHeader with 3-1/2" Flange
387HDSC300-68	3-7/8"	3"	68 (14)	50	4" RedHeader or HDS with 3" Flange
387HDSC350-68		3-1/2"			4" RedHeader with 3-1/2" Flange
587HDSC300-68	5-7/8"	3"	68 (14)	50	6" RedHeader or HDS with 3" Flange
587HDSC350-68		3-1/2"			6" RedHeader with 3-1/2" Flange
787HDSC300-68	7-7/8"	3"	68 (14)	50	8" RedHeader or HDS with 3" Flange
787HDSC350-68		3-1/2"			8" RedHeader with 3-1/2" Flange

All material G90. Sold in pairs.

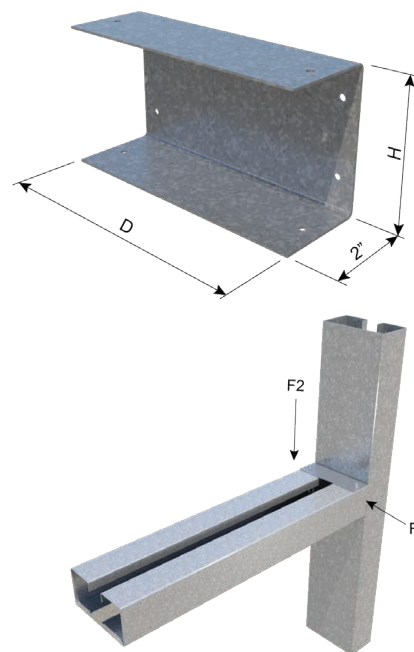

### Allowable Loads (lbs) for 3" & 3-1/2" Flange Header Systems

Product Code	Bracket Specs		Framing Member Specs		Fasteners		Capacities (lbs)					
	Depth (D)	Height (H)	Thickness Mils (Gauge)	Yield Strength, Fy (ksi)	Jamb	Header	F1 Load (Lateral)			F2 Load (Vertical)		
							Nominal (lbs)	ASD Load (lbs)	LRFD Load (lbs)	Nominal (lbs)	ASD Load (lbs)	LRFD Load (lbs)
350HDSC300-68	3-1/2"	3"	33 (20)	33	4 x #10	4 x #10	1435	705	1060	880	300	480
			43 (18)	33			2365	1050	1575	1130	390	620
			54 (16)	50			3185	1095	1755	2380	820	940
			68 (14)	50			3415	1175	1880	2920	1005	1385
			97 (12)	50			3940	1355	2170	3645	1255	1875
350HDSC350-68	3-1/2"	3-1/2"	54 (16)	50	4 x #10	4 x #10	2975	1025	1640	2150	740	1145
			68 (14)	50			3375	1160	1855	2925	1005	1555
			97 (12)	50			3810	1310	2100	3555	1225	1730
387HDSC300-68	3-7/8"	3"	33 (20)	33	4 x #10	4 x #10	1405	705	1060	885	305	485
			43 (18)	33			2210	1050	1575	1225	420	670
			54 (16)	50			3185	1095	1755	2380	820	940
			68 (14)	50			3475	1195	1910	3130	1075	1450
			97 (12)	50			4000	1375	2200	3815	1310	1700
387HDSC350-68	3-7/8"	3-1/2"	54 (16)	50	4 x #10	4 x #10	3070	1055	1690	2300	790	1145
			68 (14)	50			3395	1165	1870	3065	1055	1490
			97 (12)	50			4365	1500	2400	3825	1315	1850
587HDSC300-68	5-7/8"	3"	33 (20)	33	4 x #10	4 x #10	1370	700	1060	895	305	490
			43 (18)	33			2055	1050	1575	1315	450	725
			54 (16)	50			3265	1120	1795	2460	845	1045
			68 (14)	50			3535	1215	1945	3345	1150	1515
			97 (12)	50			4000	1375	2200	3815	1310	1700
587HDSC350-68	5-7/8"	3-1/2"	54 (16)	50	4 x #10	4 x #10	3070	1055	1690	2300	790	1145
			68 (14)	50			3415	1175	1880	3210	1105	1430
			97 (12)	50			4110	1415	2265	3955	1360	1820
787HDSC300-68	7-7/8"	3"	33 (20)	33	4 x #10	4 x #10	1370	700	1060	895	305	490
			43 (18)	33			2115	1050	1575	1245	425	670
			54 (16)	50			3340	1150	1840	2535	870	1145
			68 (14)	50			3440	1180	1895	3425	1180	1575
			97 (12)	50			4060	1395	2235	3985	1370	1525
787HDSC350-68	7-7/8"	3-1/2"	54 (16)	50	4 x #10	4 x #10	3165	1090	1745	2455	845	1145
			68 (14)	50			3420	1175	1880	3360	1155	1370
			97 (12)	50			3860	1330	2125	4090	1405	1785

**Notes:**

- Listed Capacities were derived from calculations and structural tests in accordance with provisions of AISI S100 and ICC-ES AC261.
- The safety factor for ASD loads and resistance factor for LRFD loads are calculated in accordance with Chapter K.
- The capacity of a given HDSC connection is the minimum of the corresponding jamb and the header values. For example, for a 3-1/2" HDSC-68 bracket (3" Flange) used with a 54mils (16ga) 50 ksi jamb and a 97mils (12ga) 50 ksi header, the F2 allowable design load shall be the capacity corresponding to framing member with lesser thickness i.e., 16ga member. Thus, the ASD capacity is 820 lbs.
- #10-16 HWH Screws by ITW Buildex were used to attach Brackets to Jamb and Header. The screws shall have a minimum shear capacity of 1400 lbs and minimum tension capacity of 1158 lbs. Evidence shall be provided to the building official for approval that defines the fasteners meet the performance requirements of this report, ASTM C1513 and are for use with cold-formed steel.
- For simultaneous F1 and F2 loading, use the following interaction equation:  $(F1/F1)^2 + (F2/F2)^2 \leq 1.0$  Where f1 and f2 are the applied loads and F1 and F2 are the appropriate allowable loads.
- It is the responsibility of the design professional to detail the project drawings for proper HDSC bracket installation.



### HDSC 97mils (12ga) Header Brackets (3" & 3-1/2" Flange)

Product Code	Bracket Specs		Framing Member Specs		Designed to Support
	Depth (D)	Height (H)	Thickness Mils (Gauge)	Yield Strength, Fy (ksi)	
350HDSC300-97	3-1/2"	3"	97 (12)	50	3-5/8" RedHeader or HDS with 3" Flange
350HDSC350-97		3-1/2"			3-5/8" RedHeader with 3-1/2" Flange
387HDSC300-97	3-7/8"	3"	97 (12)	50	4" RedHeader or HDS with 3" Flange
387HDSC350-97		3-1/2"			4" RedHeader with 3-1/2" Flange
587HDSC300-97	5-7/8"	3"	97 (12)	50	6" RedHeader or HDS with 3" Flange
587HDSC350-97		3-1/2"			6" RedHeader with 3-1/2" Flange
787HDSC300-97	7-7/8"	3"	97 (12)	50	8" RedHeader or HDS with 3" Flange
787HDSC350-97		3-1/2"			8" RedHeader with 3-1/2" Flange

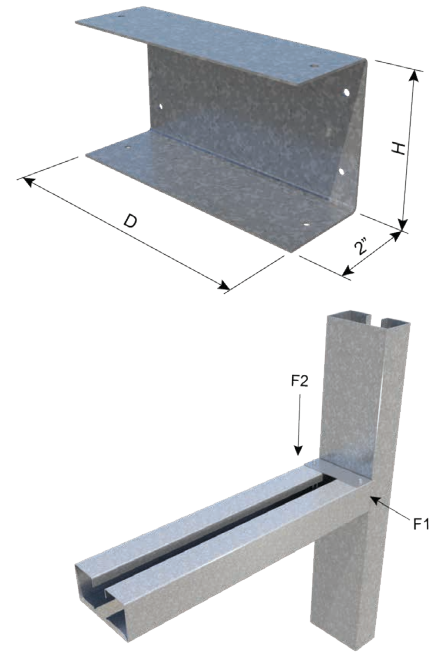

All material G90. Sold in pairs.

### Allowable Loads (lbs) for 3" & 3-1/2" Flange Header Systems

Product Code	Bracket Specs		Framing Member Specs		Fasteners		Capacities (lbs)					
	Depth (D)	Height (H)	Thickness Mils (Gauge)	Yield Strength, Fy (ksi)	Jamb	Header	F1 Load (Lateral)			F2 Load (Vertical)		
							Nominal (lbs)	ASD Load (lbs)	LRFD Load (lbs)	Nominal (lbs)	ASD Load (lbs)	LRFD Load (lbs)
350HDSC300-97	3-1/2"	3"	33 (20)	33	4 x #12	4 x #12	1435	735	1130	880	300	495
			43 (18)	33			2490	1120	1680	1375	470	865
			54 (16)	50			4025	1385	2215	2195	755	1410
			68 (14)	50			4340	1490	2390	3465	1190	2000
			97 (12)	50			6075	2090	3345	5610	1930	2380
350HDSC350-97	3-1/2"	3-1/2"	54 (16)	50	4 x #12	4 x #12	4080	1400	2245	2145	735	1545
			68 (14)	50			4265	1465	2350	3575	1230	2090
			97 (12)	50			6005	2065	3305	5385	1850	2405
			33 (20)	33			1405	720	1130	885	305	550
387HDSC300-97	3-7/8"	3"	43 (18)	33	4 x #12	4 x #12	2490	1120	1680	1375	470	865
			54 (16)	50			4105	1410	2260	2405	825	1455
			68 (14)	50			4105	1410	2260	3360	1155	1530
			97 (12)	50			6000	2065	3305	5840	2010	2560
			54 (16)	50			3975	1365	2185	2230	765	1620
387HDSC350-97	3-7/8"	3-1/2"	68 (14)	50	4 x #12	4 x #12	4195	1445	2310	3630	1250	2080
			97 (12)	50			6185	2130	3405	5500	1890	2455
			33 (20)	33			1370	700	1125	895	305	610
			43 (18)	33			2345	1120	1680	1400	480	820
587HDSC300-97	5-7/8"	3"	54 (16)	50	4 x #12	4 x #12	4340	1475	2390	2615	900	1500
			68 (14)	50			4340	1490	2390	3465	1190	2000
			97 (12)	50			5930	2040	3265	6065	2085	2740
			54 (16)	50			3870	1330	2130	2310	795	1690
			68 (14)	50			4195	1445	2310	3630	1250	2080
587HDSC350-97	5-7/8"	3-1/2"	97 (12)	50	4 x #12	4 x #12	6060	2085	3335	5840	2010	2400
			33 (20)	33			1370	700	1125	895	305	610
			43 (18)	33			2200	1120	1680	1420	485	770
			54 (16)	50			4125	1420	2270	2945	1015	1485
			68 (14)	50			4125	1420	2270	3685	1265	2070
787HDSC300-97	7-7/8"	3"	97 (12)	50	4 x #12	4 x #12	5770	1985	3175	6085	2090	2710
			4070	1400			2240	2625	905	1505		
			4125	1420			2270	3685	1265	2070		
			5935	2040			3265	6180	2125	2350		
			54 (16)	50			4070	1400	2240	2625	905	1505

**Notes:**

- Listed Capacities were derived from calculations and structural tests in accordance with provisions of AISI S100 and ICC-ES AC261.
- The safety factor for ASD loads and resistance factor for LRFD loads are calculated in accordance with Chapter K.
- The capacity of a given HDSC connection is the minimum of the corresponding jamb and the header values. For example, for a 3-1/2" HDSC-97 bracket (3" Flange) used with a 54mils (16ga) 50 ksi jamb and a 97mils (12ga) 50 ksi header, the F2 allowable design load shall be the capacity corresponding to framing member with lesser thickness i.e., 16ga member. Thus, the ASD capacity is 755 lbs.
- #12-14 HWH Screws by ITW Buildex were used to attach Brackets to Jamb and Header. The screws shall have a minimum shear capacity of 2000 lbs and minimum tension capacity of 2325 lbs. Evidence shall be provided to the building official for approval that defines the fasteners meet the performance requirements of this report, ASTM C1513 and are for use with cold-formed steel.
- For simultaneous F1 and F2 loading, use the following interaction equation:  $(F1/F1)^2 + (F2/F2)^2 \leq 1.0$  Where F1 and F2 are the applied loads and F1 and F2 are the appropriate allowable loads.
- It is the responsibility of the design professional to detail the project drawings for proper HDSC bracket installation.

## Aluminum Burn Clip

Melting away under intense heat, clips allow a fire-damaged structure to collapse while keeping the firewall barrier in place, protecting adjacent units.

ClarkDietrich aluminum burn clips are used as part of the H-stud area separation wall assembly and are designed to melt and break away when exposed to fire. The clips are used to hold the area separation wall assembly in place at the floor roof and truss line between adjacent units.

Should a fire break out in one unit, the aluminum burn clips on the fire-ridden side of the area separation wall will melt, allowing the wall structure for that side to collapse. Without pulling the area separation wall down, the burn clips on the non-fire side will remain intact, and hold the area separation wall in place as a barrier to contain the fire within the unit of origin.

### PRODUCT DIMENSIONS

- 2" x 2" x 2-1/2"
- 2" x 2" x 3"
- 2" x 2" x 3-1/2"
- 2" x 2" x 4"
- 2" x 2" x 4-1/2"

### MATERIAL SPECIFICATIONS

All burn clips are manufactured using 5052 H32 aluminum. Standard product manufactured with .050 material. Extra-heavy duty product (AB63) manufactured with .063 material is available on request.

### INSTALLATION

Attach an aluminum burn clip to the completed area separation wall assembly. One clip should be located at each H-stud on both sides of the wall. Attach the aluminum burn clip to the H-stud with screws, not nails. Attach to the adjacent framing with Type-W or Type-S screws.

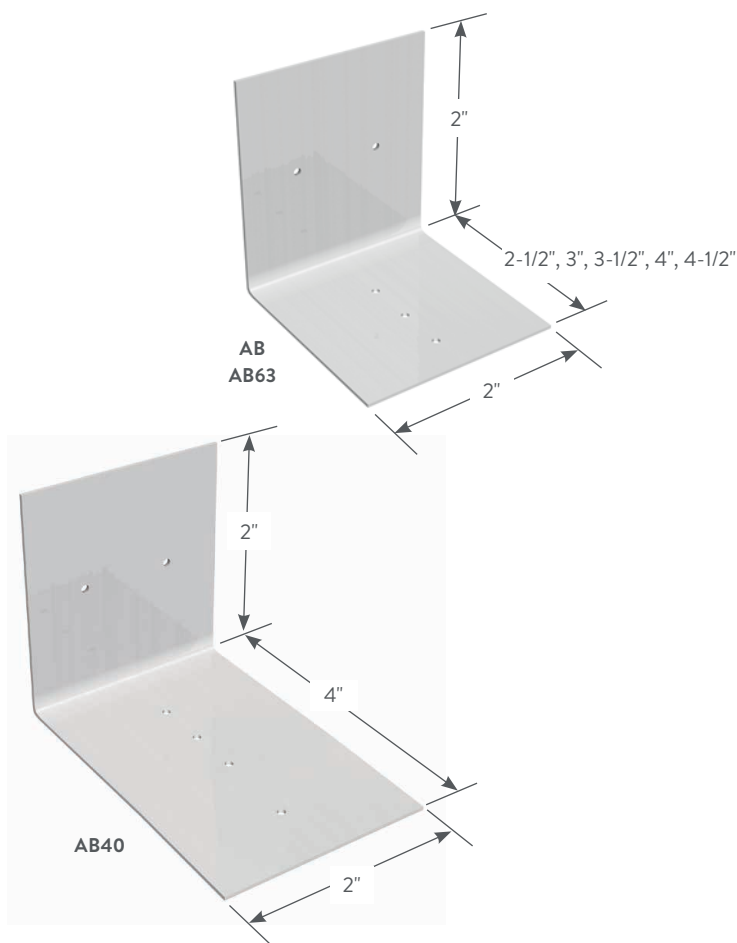

### Aluminum Burn Clips (AB)

Product code	Thickness (in)	Size (in)	Packaging Pcs./Bucket
AB	0.050	2 x 2 x 2-1/2	500
AB63	0.063	2 x 2 x 2-1/2	500
AB30	0.063	2 x 2 x 3	250
AB35	0.063	2 x 2 x 3-1/2	250
AB40*	0.063	2 x 2 x 4	250
AB45	0.063	2 x 2 x 4-1/2	250

\*AB40-For use with 3-hour Design Assembly based on GA file No. ASW 2600.

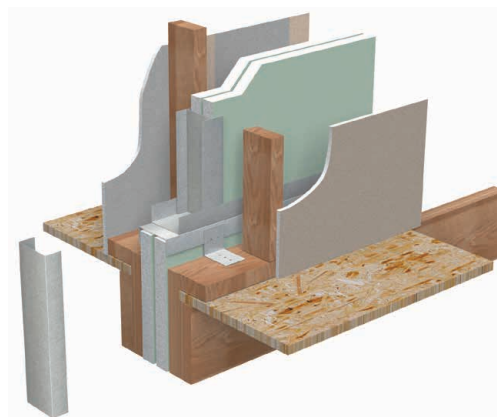

## Grommet for Stud Knockouts

Protect and isolate electrical wiring and plumbing from contacting metal.

Grommets snap easily into stud knockouts and are used to protect electrical wiring and plumbing lines from contacting metal. They also help to prevent and eliminate pipe rattle. Grommets are commonly used in residential construction when metal conduit is not required by building code.

### INSTALLATION

Install grommets in all stud knockouts where wiring and plumbing lines will be inserted. Use the snap-in bushing grommet for 1-5/8" and 2-1/2" wall studs and the standard grommet for all wall studs 3-1/2" and wider.

Install the snap-in bushing by pressing the bushing into the stud knockout. Make sure to engage the bushing lips to secure into place.

Install the standard grommet by first opening the grommet as illustrated above. Insert one side of the grommet through the knockout. Snap the grommet together so it engages with the metal sandwiched between the two plastic sides.



2-Piece Grommet

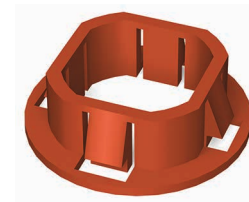

Snap-In Bushing



Grommet for 3-1/2" and Wider Studs

### Grommet (GROM)

Product code	Size (in)	Description	Pcs./Carton
GROM	3/4	For 1-5/8" and 2-1/2" studs	100
	1-1/2	For 3-1/2" and wider studs	100

## ClarkDietrich Sound Clip™

### Sound isolation and dampening clip.

The ClarkDietrich Sound Clip™ is used in conjunction with 18mils (25ga) 7/8" deep drywall furring channel. It is used to fasten gypsum wallboard in various wall and floor-ceiling applications, while simultaneously providing acoustical separation. This significantly reduces the amount of airborne sound filtering from room to room. The ClarkDietrich Sound Clip adds notable STC points to most assemblies while reducing sound transfer.

- Ideal for use in multi-family dwelling, hotels, theaters and hospitals
- Used in conjunction with 7/8" 25 ga Furring Channel with a total standoff from stud of 1-5/8"
- UL fire rated for most common assemblies
- Complies to UL 263 test standards.
- Max. spacing 48" o.c. (laterally) x 24" o.c. (vertically)
- Maximum acoustical design load is 36 lbs.
- Sound testing for Type X & Type C Boards

### PRODUCT DIMENSIONS

3" x 1-1/4" (Clip only)

### MATERIAL SPECIFICATIONS

**Gauge:** 18 gauge (43mils)

**Design Thickness:** 0.0451 inches

**Yield Strength:** 33ksi

**Coating:** CP60

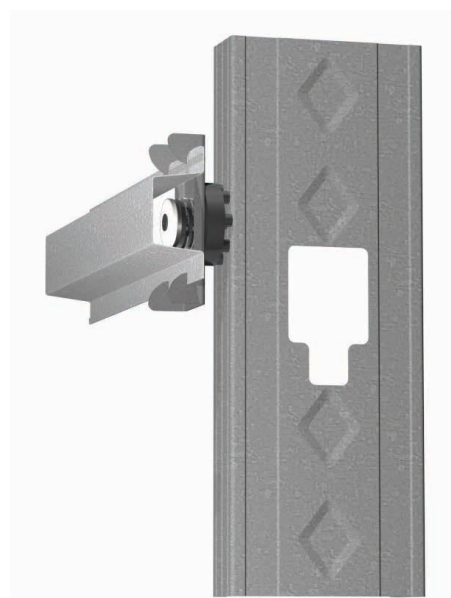
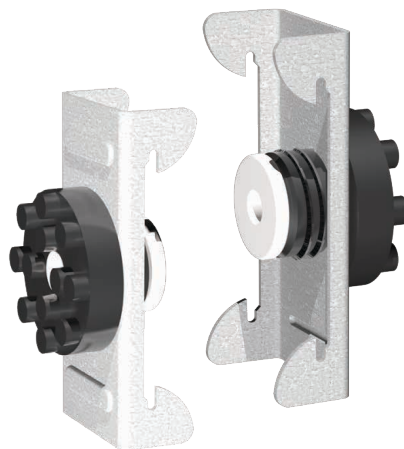

### ClarkDietrich Sound Clip (CDSC)

Product code	Mils (Gauge)	Size (in)	Pcs./Bucket
CDSC	43mils (18ga)	3 x 1-1/4	100

### SOUND AND UL DESIGN:

- Complies to UL 263 test standards. See full list of UL® design assemblies in UL R19331.
- Wall Sound Assemblies are certified by Western Electro-Acoustical Laboratories.
- Floor Sound Assemblies are certified by Intertek Building & Construction (B&C).
- NVLAP Accredited for ASTM E90 & E413, ISO Certified

## CDSC STC SOUND ASSEMBLIES ON METAL STUD FRAMING

Fire Rating	UL Assembly	Wall Framing	Stud Spacing	Wall Board (Side1/Side2)	Insulation	STC Rating	OITC Rating	Test Report
		3-5/8" ProSTUD 20 33mils	24" o.c.	(1) layer / (1) layer 5/8" Type C	R-19	60		TL18-291
		3-5/8" ProSTUD 20 33mils	24" o.c.	(1) layer / (2) layers 5/8" Type C	R-19	62		TL18-292
		3-5/8" ProSTUD 20 33mils	24" o.c.	(2) layers / (2) layers 5/8" Type C	R-19	63		TL18-293
		3-5/8" ProSTUD 25 15mils	16" o.c.	(1) layer / (1) layer 5/8" Type X	R-11	56		TL18-199
		3-5/8" ProSTUD 25 15mils	16" o.c.	(1) layer / (2) layers 5/8" Type X	R-11	60		TL18-197
		3-5/8" ProSTUD 25 15mils	16" o.c.	(2) layers / (2) layers 5/8" Type X	R-11	62		TL18-194
2 Hr	U411	2-1/2" ProSTUD 25 15mils	24" o.c.	(2) layers / (2) layers 5/8" Type X	R-13	62	48	L3173.08-113-11-R0
3/4 Hr	U423	3-1/2" Structural Stud 33mils	24" o.c.	(1) layer / (1) layer 1/2" Type C	R-19	53	37	L3173.10-113-11-R0
1 Hr	U423	3-1/2" Structural Stud 33mils	24" o.c.	(1) layer / (1) layer 1/2" Type X	R-19	55	38	L3173.12-113-11-R0
1-1/2 Hr	U423	3-1/2" Structural Stud 33mils	24" o.c.	(2) layers / (2) layers 1/2" Type C	R-19	62	48	L3173.11-113-11-R0
2 Hr	U423	3-1/2" Structural Stud 33mils	24" o.c.	(2) layers / (2) layers 5/8" Type X	R-19	63	50	L3173.13-113-11-R0
1 Hr	U465	3-5/8" ProSTUD 20 18mils	24" o.c.	(1) layer / (1) layer 5/8" Type X	None	45	29	L3173.03-113-11-R0
1 Hr	U465	3-5/8" ProSTUD 20 18mils	24" o.c.	(1) layer / (1) layer 5/8" Type X	Mineral Wool	53	36	L3173.04-113-11-R0
1 Hr	U465	3-5/8" ProSTUD 20 18mils	24" o.c.	(1) layer / (1) layer 5/8" Type X	R-13	53	37	L3173.05-113-11-R0
1 Hr	U493	(2) 2-1/2" ProSTUD 25 15 mils - ChaseWall	24" o.c.	(1) layer / (1) layer 5/8" Type X	R-13 Both Sides	60	44	L3173.06-113-11-R0
2 Hr	U493	(2) 2-1/2" ProSTUD 25 15 mils - ChaseWall	24" o.c.	(2) layers / (2) layers 5/8" Type X	R-13 Both Sides	67	53	L3173.07-113-11-R0
1 Hr	V438	2-1/2" ProSTUD 25 15 mils	24" o.c.	(1) layer / (1) layer 1/2" Type C	R-13	49	34	L3173.09-113-11-R0
2 Hr	V438	1-5/8" ProSTUD 25 15 mils	24" o.c.	(2) layers / (2) layers 1/2" Type C	2-3/4" Fiberglass	59	42	L3173.14-113-11-R0
3 Hr	V438	1-5/8" ProSTUD 25 15 mils	24" o.c.	(3) layers / (3) layers 1/2" Type C	2-3/4" Fiberglass	63	49	L3173.15-113-11-R0
4 Hr	V438	1-5/8" ProSTUD 25 15 mils	24" o.c.	(4) layers / (4) layers 1/2" Type C	2-3/4" Fiberglass	66	53	L3173.16-113-11-R0

**Wall Tests:** The test was performed in accordance with ASTM E 90-09 (2016), Standard Test Method for Laboratory Measurement of Airborne Sound Transmission Loss of Building Partitions and ASTM E2235-04 (2012), Standard Test Method for Determination of Decay Rates for Use in Sound Insulation Test Methods.

**Floor/Ceiling Tests:** Available from ClarkDietrich Technical Services.

## ClarkDietrich Sound Clip™

## CDSC STC SOUND ASSEMBLIES ON 2x4 WOOD STUDS

Fire Rating	UL Assembly	Wall Framing	Stud Spacing	Wall Board (Side1/Side2)	Insulation	STC Rating	OITC Rating	Test Report
		2x4 Wood Studs	16" o.c.	(1) layer / (1) layer 5/8" Type X	R-19	53		TL18-201
		2x4 Wood Studs	16" o.c.	(1) layer / (1) layer 5/8" Type C	R-19	60		TL18-288
		2x4 Wood Studs	16" o.c.	(1) layer / (2) layers 5/8" Type X	R-19	57		TL18-204
		2x4 Wood Studs	16" o.c.	(1) layer / (2) layers 5/8" Type C	R-19	61		TL18-289
		2x4 Wood Studs	16" o.c.	(2) layers / (2) layers 5/8" Type X	R-19	61		TL18-205
		2x4 Wood Studs	16" o.c.	(2) layers / (2) layers 5/8" Type C	R-19	62		TL18-290
2 Hr	U301	2x4 Wood Studs	16" o.c.	(2) layers / (2) layers 5/8" Type X	R-13	60	47	L3173.01-113-11-R0
1 Hr	U309	2x4 Wood Studs	24" o.c.	(1) layer / (1) layer 5/8" Type X	R-19	53	37	L3173.17-113-11-R0
1 Hr	U311	2x4 Wood Studs	24" o.c.	(1) layer / (1) layer 5/8" Type C	R-19	55	39	L3173.18-113-11-R0
1 Hr	U340	2x4 Wood Studs - Chase Wall	12" o.c. Staggered	(1) layer / (1) layer 5/8" Type X	R-19	57	43	L3173.21-113-11-R0
1 Hr	U341	2x4 Wood Studs - Chase Wall	24" o.c.	(1) layer / (1) layer 5/8" Type X	R-19	60	45	L3173.20-113-11-R0
1 Hr	U344	2x4 Wood Studs	24" o.c.	(1) layer 5/8" Type X / (1) layer 5/8" Plywood + 5/8" Type X	R-19	57	41	L3173.19-113-11-R0
1 Hr	U356	2x4 Wood Studs	16" o.c.	7/16" Plywood / (1) layer 5/8" Type X	R-13	51	34	L3173.02-113-11-R0

**Wall Tests:** The test was performed in accordance with ASTM E 90-09 (2016), Standard Test Method for Laboratory Measurement of Airborne Sound Transmission Loss of Building Partitions and ASTM E2235-04 (2012), Standard Test Method for Determination of Decay Rates for Use in Sound Insulation Test Methods.

**Floor/Ceiling Tests:** Available from ClarkDietrich Technical Services.



**10" TradeReady® STEEL JOISTS W/LEVELROCK  
(UL DESIGN NO. G551)**

Material Description	STC	IIC	Test Report
Carpet w/ Pad	55	80	J4775.02
Ceramic w/ NobleSeal®	57	50	J4775.06
Shaw Engineered Wood	54	50	J4775.03
Shaw Como Vinyl 12mm	55	48	J4775.04
Shaw Expo Vinyl 6mm	54	47	J4775.05
Baseline System UL Design No. G551 Ceiling: (1) layer 5/8" Type C	54	43	J4775.01
+(1) Gypsum C-Core Layer with: Shaw Expo Vinyl 6mm on top of the floor UL Design No. G551	58	51	J4775.07

**16" WOOD OPEN WEB TRUSS (OWT) W/LEVELROCK  
(UL DESIGN NO. UL-L521)**

With (1) layer 5/8" Type C attached to hat channel.

Material Description	STC	IIC	Test Report
Carpet w/ Pad	59	79	J4777.02
Ceramic w/ NobleSeal®	59	53	J4777.06
Shaw Engineered Wood	58	53	J4777.03
Shaw Como Vinyl 12mm	58	51	J4777.04
Shaw Expo Vinyl 6mm	58	51	J4777.05
Baseline System (Nothing on top of LevelRock) UL Design No. UL-L521 Ceiling: (1) layer 5/8" Type C	58	50	J4777.01

**16" WOOD OPEN WEB TRUSS (OWT) W/LEVELROCK  
(UL DESIGN NO. UL-M510)**

With (1) layer 5/8" Type C on the bottom of the joist + (2) layers 5/8" Type C attached to hat channel.

Material Description	STC	IIC	Test Report
Carpet w/ Pad	58	75	J4778.02
Ceramic w/ NobleSeal®	57	51	J4778.06
Shaw Engineered Wood	58	50	J4778.03
Shaw Como Vinyl 12mm	58	49	J4778.04
Shaw Expo Vinyl 6mm	58	50	J4778.05
Baseline System (Nothing on top of LevelRock) UL Design No. UL-M510 Ceiling: (1) layer 5/8" Type C + (2) layers 5/8" Type C	58	50	J4778.01

**12" WOOD TRUSS JOINT (TJI) W/LEVELROCK  
(UL DESIGN NO. UL-L518)**

With (2) layers 1/2" Type C attached to hat channel.

Material Description	STC	IIC	Test Report
Carpet w/ Pad	62	84	J4776.03
Ceramic w/ NobleSeal®	63	56	J4776.07
Shaw Engineered Wood	62	56	J4776.04
Shaw Como Vinyl 12mm	62	54	J4776.05
Shaw Expo Vinyl 6mm	61	53	J4776.06
Baseline System (Nothing on top of LevelRock) UL Design No. UL-L518 Ceiling: (2) layers 1/2" Type C	62	50	J4776.02

**8" CONCRETE SLAB W/ (1) LAYER GYPSUM CEILING**

With (1) layer 5/8" Type X attached to hat channel.

Material Description	STC / Test Report	IIC / Test Report
Carpet Tiles	62 RAL-TL21-030	61 RAL-IN21-009
Vinyl Planks 7mm	63 RAL-TL21-031	61 RAL-IN21-010
Baseline System (Nothing on top of 8" Concrete)  Ceiling: R-6.7 unfaced fiberglass insulation + (1) layer 5/8" Type X	62 RAL-TL21-032	60 RAL-IN21-011

**8" CONCRETE SLAB W/ (1) LAYER GYPSUM CEILING**

With (2) layers 5/8" Type X attached to hat channel.

Material Description	STC / Test Report	IIC / Test Report
Carpet Tiles	63 RAL-TL21-029	61 RAL-IN21-008
Vinyl Planks 7mm	63 RAL-TL21-020	64 RAL-IN21-003
Baseline System (Nothing on top of 8" Concrete)  Ceiling: R-6.7 unfaced fiberglass insulation + (2) layers 5/8" Type X	63 RAL-TL21-027	64 RAL-IN21-006

**Wall Tests:** The test was performed in accordance with ASTM E 90-09 (2016), Standard Test Method for Laboratory Measurement of Airborne Sound Transmission Loss of Building Partitions and ASTM E2235-04 (2012), Standard Test Method for Determination of Decay Rates for Use in Sound Insulation Test Methods.

**Floor/Ceiling Tests:** Available from ClarkDietrich Technical Services.

## ClarkDietrich Sound Clip™ Installation Guide

### FURRING CHANNEL:

7/8" 25-gauge hemmed furring channel (7/8" fur, 1-1/4" top & 2-23/32" bottom)

- When splicing, drywall furring channel should have 6 inch overlap in mid span (between two clips) secure with 18ga tie wire, or two 7/16" framing screws. If using in a fire-rated UL application; use only tie wire and no screws.

### CLARKDIETRICH SOUND CLIP:

3" x 1-1/4" (clip only) maximum spacing 48" o.c. and maximum design load is 36 lbs.

### FASTENERS:

- CDSC to Wood: 64mm (2-1/2") # 8 minimum size coarse thread screw. (Recommended #12 or #10 x 2-1/2" hex head)
- CDSC to Steel: 38 mm (1-1/2") # 8 minimum size fine thread screw. (Recommended #12 or #10 x 1-5/8" hex head)
- CDSC to Concrete or CMU: 1/4" drop-in anchor, 1/4" drive spike, 3/16" x tapcon, shoot in pin with washer, or product with equal load capabilities (Minimum 120 lbs Ultimate, Shear and Pullout). Length of fastener determined by the concrete type, strength, and fastener minimum embed requirements.
- DO NOT attach CDSC to framing members with nails; use only approved screws.

### WALLS: ONE AND TWO LAYERS OF 5/8" GYPSUM BOARD

- ClarkDietrich Sound Clip (CDSC) shall be 48" maximum o.c. (horizontal).
- Fasten the CDSC to the substrate with a fastener approved for a minimum pull-out and shear of 120lbs.
- Locate the first row of CDSC within 3-6 inches from the floor and within 3-6 inches from the top track, making sure the clip is attached to the studs and not the track.
- Snap in the drywall furring channel into the CDSC clips (horizontal for walls).
- Place 1/4" (minimum) shim on floor to fully support the gypsum board.
- Install the gypsum board from the bottom up leaving a 1/4" minimum gap around the perimeter of the wall.
- ONLY remove the shims after ALL the gypsum board is completely screwed to ALL the drywall furring channels. Make sure every screw (floor-to-ceiling and wall-to-wall) is installed as required by the assembly design, in every layer of gypsum board before removing the shims at the floor. The shims are critical to ensure best results.
- Caulk around the entire perimeter of the gypsum board. Use fire and smoke rated acoustical sealant where required.

### CEILINGS: ONE AND TWO LAYERS OF 5/8" GYPSUM BOARD

- CDSC shall be 48" maximum o.c.
- Fasten the CDSC to the substrate with a fastener approved for a minimum pull-out and shear of 120lbs.
- Locate the first row CDSC clips within 8" of the wall at each end of a run.
- Snap in the drywall furring channel into the CDSC clips. Channel max spacing at 24" o.c.
- Install the gypsum board from leaving a 1/4" min. gap around the perimeter of the ceiling.
- Caulk around the entire perimeter of the gypsum board. Use fire and smoke rated acoustical sealant where required.

### GENERAL INFORMATION:

- Refer to [www.UL.com](http://www.UL.com), or [www.clarkdietrich.com](http://www.clarkdietrich.com) for complete installation details on all fire resistive assembly designs.
- ClarkDietrich Sound Clips, furring channel and gypsum board shall not carry heavy loads such as cabinets or bookshelves.
- Seal all potential air leaks with non-hardening acoustical caulking to achieve best noise control results. Use fire rated sealant where required.

### FIRE TEST INFORMATION:

Visit [clarkdietrich.com](http://clarkdietrich.com) for the latest fire testing approvals and updates.

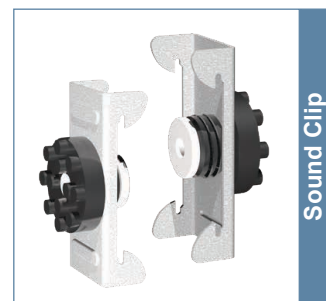
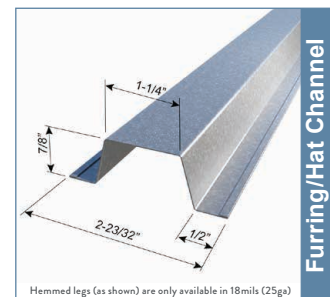

## WALL AND CEILING INSTALLATION GUIDE FOR WOOD OR STEEL FRAMING WITH FURRING ON 24" CENTERS

Wall or Ceiling framing at 24" o.c.,  
CDSC at 48" o.c., furring at 24" o.c., 1 or 2 layers of 5/8" gypsum board

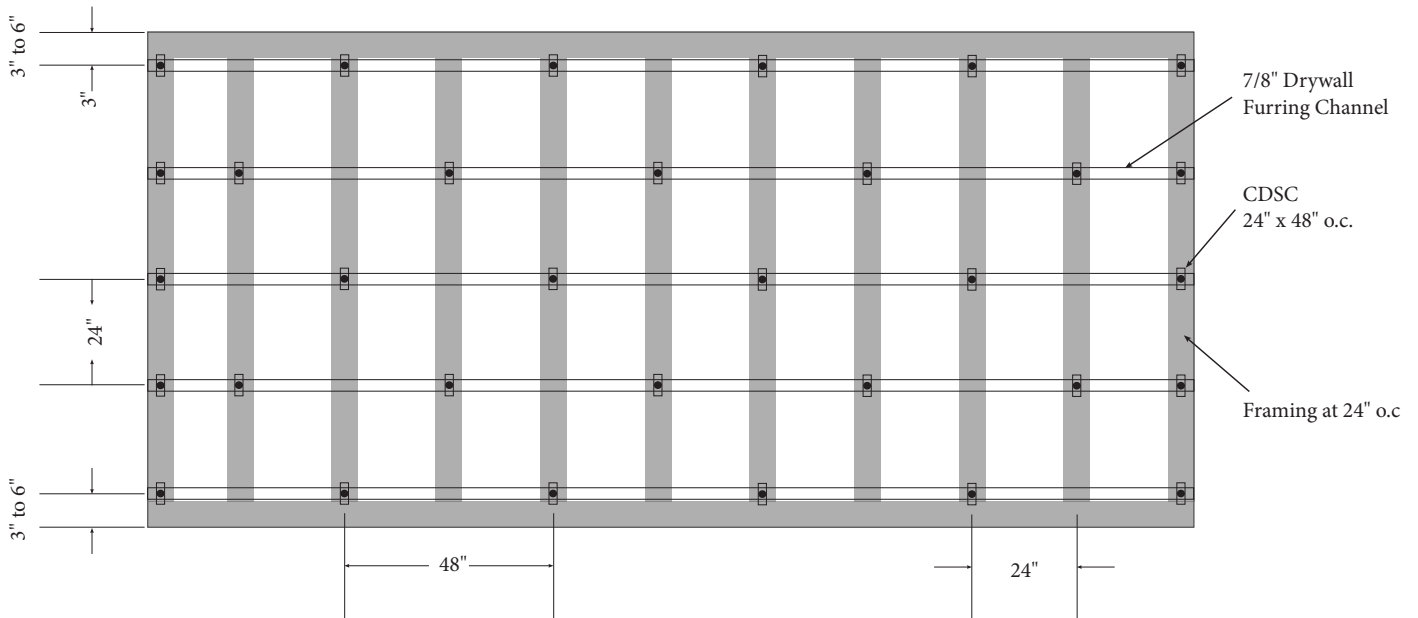

NOTE: DRAWING NOT TO SCALE

Wall or Ceiling framing at 16" o.c.,  
CDSC at 48" o.c., furring at 24" o.c., 1 or 2 layers of 5/8" gypsum board

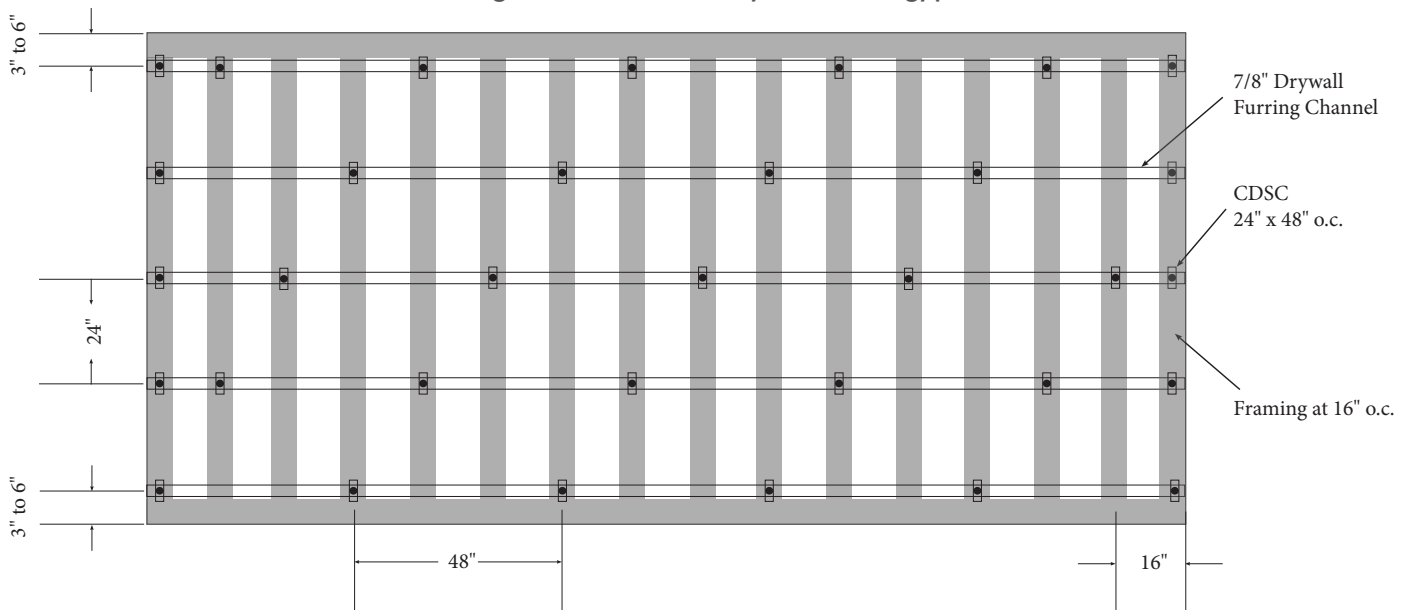

NOTE: DRAWING NOT TO SCALE

## Header Cripple Stud Clip

Eliminates the header track material and is a economical alternative.

Header Cripple Stud Clips are used with RedHeader PRO™ and HDS® Framing System and remove the need for a header track. The L-shaped clips install on the back side of the cripple stud, therefore shorter length clips do not need to be ordered. These labor time-savers include prepunched holes for quicker screw attachments, and are punched for RedHeader PRO and HDS connections.

### PRODUCT DIMENSIONS

1-1/2" x 1-1/2" x 3-3/8"  
 1-1/2" x 1-1/2" x 3-3/4"  
 1-1/2" x 1-1/2" x 5-3/4"  
 1-1/2" x 1-1/2" x 7-3/4"

### MATERIAL SPECIFICATIONS

**Gauge:** 16 gauge (54mils)  
**Design Thickness:** 0.0451 inches  
**Coating:** G90

**Gauge:** 14 gauge (68mils)  
**Design Thickness:** 0.0713 inches  
**Coating:** G90

### INSTALLATION

Header Cripple Stud Clips are attached to the cold-formed steel (CFS) framing members using #10 minimum self-drilling screws driven through the clip holes into the steel framing. It is the responsibility of the design engineer to detail the attachment of clips and verify their capacity meets the application. Place the first two screws in each leg in the outermost screw holes. The next screws (if needed) are placed moving from the outermost holes toward the center, symmetrically.

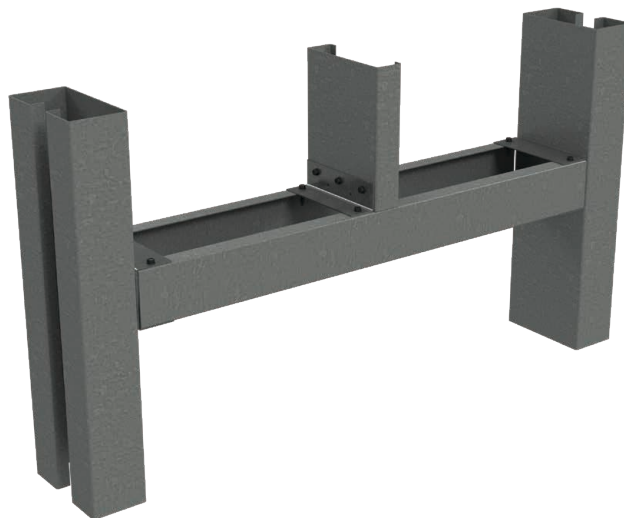

## Header Cripple Stud Clip

Product code	Mils (Gauge)	Design Thickness	Size (in)	For Header Size	Pcs./Bucket
RCSC-54-3	54mils (16ga)	0.0566"	1-1/2" x 1-1/2" x 3-3/8	3-5/8" web	400
RCSC-54-4			1-1/2" x 1-1/2" x 3-3/4	4" web	200
RCSC-54-6			1-1/2" x 1-1/2" x 5-3/4	6" web	100
RCSC-54-8			1-1/2" x 1-1/2" x 7-3/4	8" web	100
RCSC-68-3	68mils (14ga)	0.0713"	1-1/2" x 1-1/2" x 3-3/8	3-5/8" web	200
RCSC-68-4			1-1/2" x 1-1/2" x 3-3/4	4" web	200
RCSC-68-6			1-1/2" x 1-1/2" x 5-3/4	6" web	100
RCSC-68-8			1-1/2" x 1-1/2" x 7-3/4	8" web	100

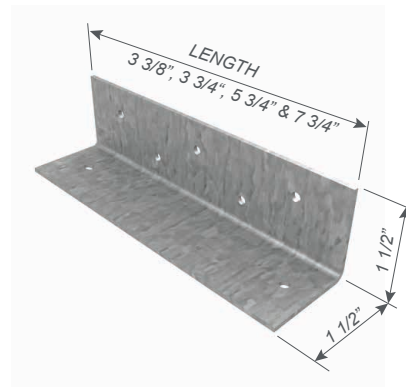

## Metal Furring Channel Clip

Quickly facilitates the attachment of metal furring channel to 1-1/2" U-channel in ceiling assemblies.

ClarkDietrich metal furring channel clips are made of galvanized wire and used to attach metal furring channels to 1-1/2" U-channels in ceiling gridwork. Clips must be installed on alternating sides of the 1-1/2" channels. Use tie wire when clips cannot be alternated. Clips should only be used when single-layer gypsum or single-layer veneer plaster base is used.

### MATERIAL SPECIFICATIONS

MFCCs, made of corrosion-resistant galvanized wire, are used in attaching metal channels to 1-1/2" cold-rolled channel ceiling grillwork. For use with gypsum panels or with single-layer veneer gypsum plaster base. See illustrations.

### INSTALLATION

MFCCs must be attached on alternate sides of the 1-1/2" U-channels. Use tie wire when clips cannot be alternated.

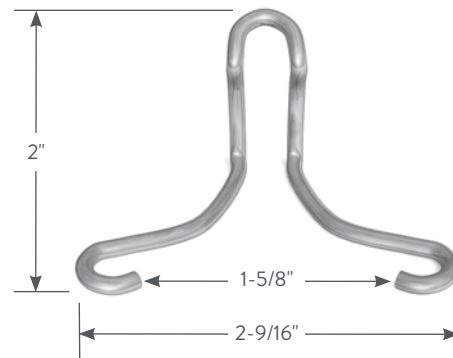

Metal Furring Channel Clip

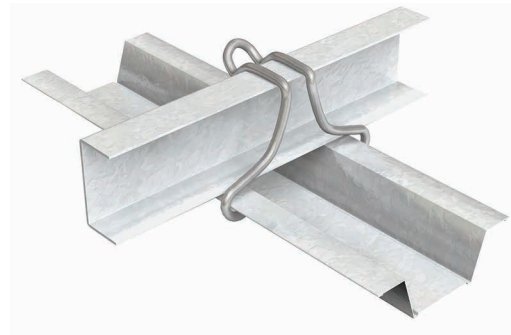
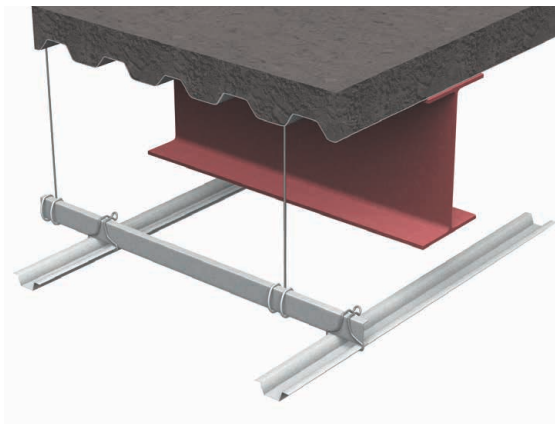

### Metal Furring Channel Clip (MFCC)

Product code	Pcs./Carton
MFCC	500

## Panel Lift Clip

Provides lifting points for prefabricated panels.

The Panel Lift Clip is load rated and is used to safely lift wall panels at assembly warehouses or on job-sites. The clip comes pre-punched for screw attachment to the panel as well as a larger hole for the clamp. The rounded design of the top of the panel clip allows for the clamp to slide freely without getting stuck on the corners. The Panel Lift Clip comes in 12ga and is offered in two sizes, 8" and 12".

### PRODUCT DIMENSIONS

**PLC8-97:** 3" wide x 8" long plate

**PLC12-97:** 3" wide x 12" long plate

### MATERIAL SPECIFICATIONS

**Material:** ASTM A 1003 Structural Grade 50

**Gauge:** 12 gauge (97mils)

**Design Thickness:** 0.1017 inches

**ASTM:** A1003, A653

Galvanized coating meets or exceeds requirements of ASTM A653.

### INSTALLATION

Install the Panel Lift Clips to each side and intermediate points of the panel. For intermediate clip installation, cut a groove large enough to insert the clip through the top track. Quantity, location and anchoring of clips to panel as designed by EOR. Panel Lift Clip is for single use only, and cannot be reused or reattached.

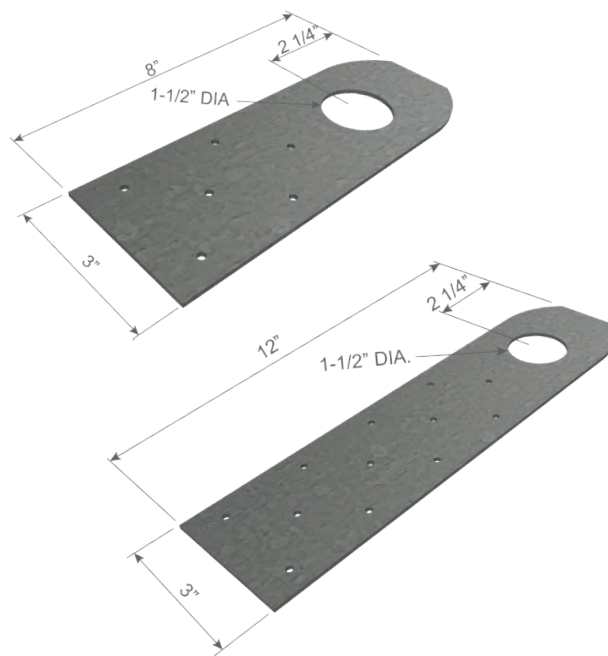

### Panel Lift Clip (PLC)

Product code	Overall Length	Pcs./Bucket
PLC8-97	8"	100
PLC12-97	12"	50

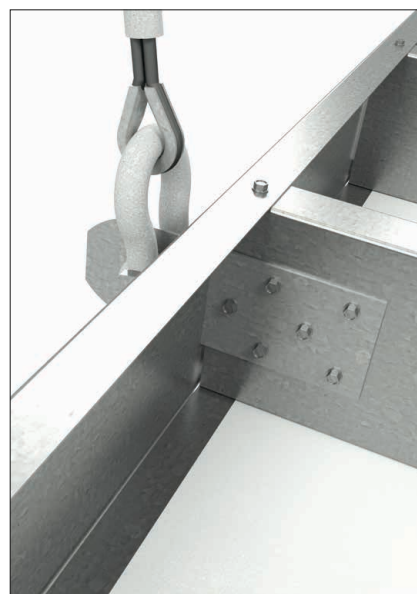
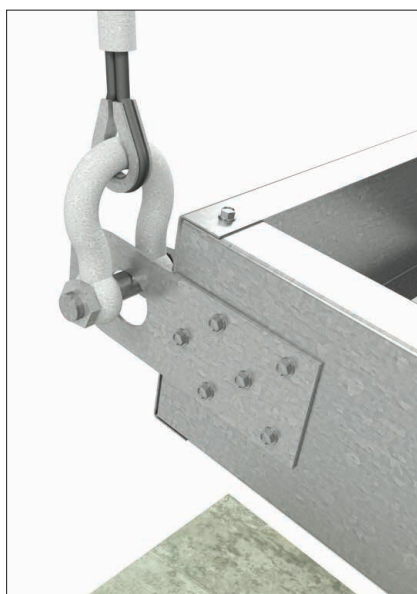

**Panel Lift Clip (PLC8, PLC12) Allowable Loads - Connection to Steel Framing, per Clip (lbs)**

Product code	Stud thickness		F3 (Panel Lifted from a Vertical Orientation)			F2 (Panel Lifted from a Horizontal Orientation)		
	Mils (Gauge)	Fy (ksi)	97mils (12ga) PLC			97mils (12ga) PLC		
			w/3 #10 screws	w/5 #10 screws	w/6 #10 screws	w/3 #10 screws	w/5 #10 screws	w/6 #10 screws
PLC8-97	33mils (20ga)	33	530	884	1060	89	205	260
	33mils (20ga)	50	766	1276	1532	129	297	375
	43mils (18ga)	33	789	1315	1578	133	306	387
	43mils (18ga)	50	1140	1900	2279	192	442	559
	54mils (16ga)	33	1109	1849	2219	187	430	544
	54mils (16ga)	50	1602	2671	2775	270	621	786
	68mils (14ga)	50	1644	2740	2775	277	637	806
97mils (12ga)	50	1644	2740	2775	277	637	806	

Product code	Stud thickness		F3 (Panel Lifted from a Vertical Orientation)			F2 (Panel Lifted from a Horizontal Orientation)		
	Mils (Gauge)	Fy (ksi)	97mils (12ga) PLC			97mils (12ga) PLC		
			w/5 #10 screws	w/8 #10 screws	w/12 #10 screws	w/5 #10 screws	w/8 #10 screws	w/12 #10 screws
PLC12-97	33mils (20ga)	33	884	1414	2121	113	231	491
	33mils (20ga)	50	1276	2042	2775	163	333	710
	43mils (18ga)	33	1315	2104	2775	168	343	731
	43mils (18ga)	50	1900	2775	2775	243	496	1056
	54mils (16ga)	33	1849	2775	2775	237	483	1028
	54mils (16ga)	50	2671	2775	2775	342	697	1085
	68mils (14ga)	50	2740	2775	2775	351	715	1085
	97mils (12ga)	50	2740	2775	2775	351	715	1085

**Notes:**

- 1 Attachment to steel framing using #10 screws with a minimum shear capacity of 1644 lbs.
- 2 The use of load distribution spreader bar is assumed for multiple lift points.
- 3 Panel Lift Clip is for single use only, and cannot be reused or reattached.

**PLC8-97**

**PLC12-97**

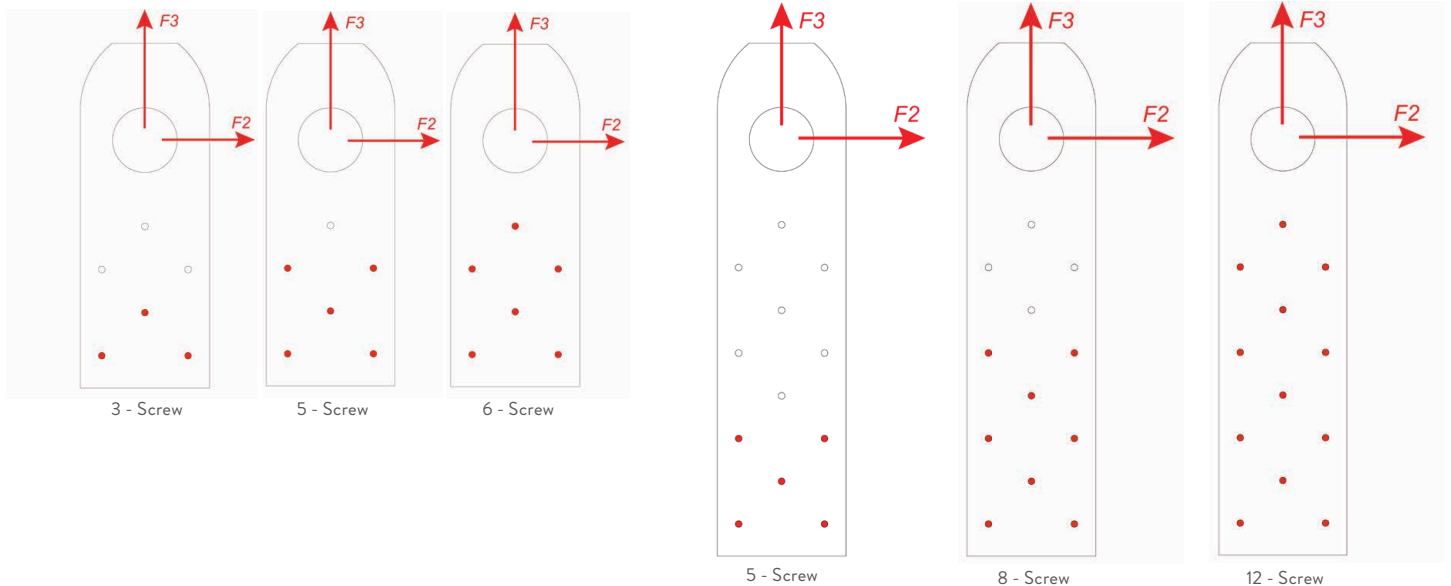

## Commercial Strapping

Multipurpose pre-punched commercial coil stock used for bracing, bridging or tension strapping.

Coil Strapping is made in a variety of widths, each with a unique layout of pre-punched holes for a variety of fastening options to meet different application requirements.

### PRODUCT DIMENSIONS

1" x 250'

1-1/2" x 250'

2" x 150'

2-1/2" x 150'

3" x 100'

### MATERIAL SPECIFICATIONS

**Material:** 50ksi, G60

**Gauge:** 20 gauge (33mils)

**Design Thickness:** 0.0346 inches

**ASTM:** A1003, A653

**Material:** 50ksi, G90 (Z275) hot-dipped galvanized

**Gauge:** 18 gauge (43mils)

**Design Thickness:** 0.0451 inches

**ASTM:** A1003, A653

### TYPICAL APPLICATIONS:

- Horizontal strap lateral bracing for wall studs
- Strap bridging for bottom of floor joists
- Tension strapping for shear wall x-bracing

### FEATURES AND BENEFITS:

- Packaged for easy grab and go on jobsite
- Various LF lengths to aid in quicker installation
- Pre-punched holes to speed up installation and improve overall installation costs (see EOR for all connections)
- Tension Load Values available

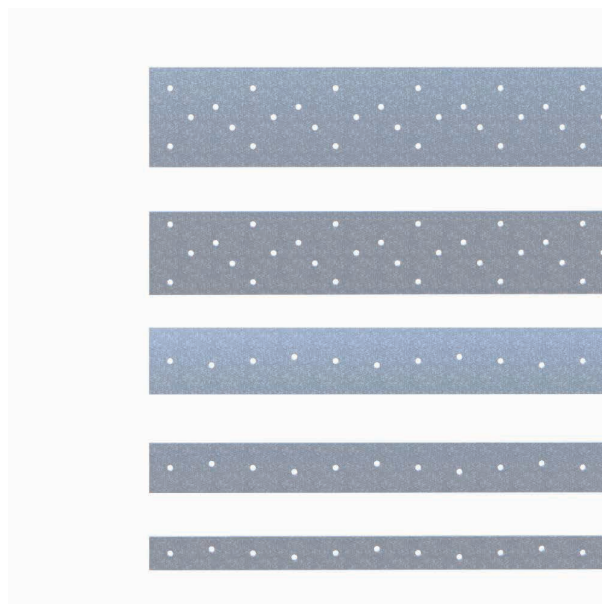

## Commercial Strapping (CS)

Product code	Thickness	Width	Coil length
CS1-250-33	33mils (20ga)	1 inch	250 ft
CS1-250-43	43mils (18ga)	1 inch	250 ft
CS1.5-200-33	33mils (20ga)	1.5 inch	200 ft
CS1.5-200-43	43mils (18ga)	1.5 inch	200 ft
CS2-150-33	33mils (20ga)	2 inch	150 ft
CS2-150-43	43mils (18ga)	2 inch	150 ft
CS2.5-150-33	33mils (20ga)	2.5 inch	150 ft
CS2.5-100-43	43mils (18ga)	2.5 inch	100 ft
CS3-100-33	33mils (20ga)	3 inch	100 ft
CS3-100-43	43mils (18ga)	3 inch	100 ft



## INSTALLATION

### Horizontal strap lateral bracing for wall studs

Lateral bracing consists of a field-cut stud or track for solid blocking and steel strap bracing on both flanges of the studs. Solid blocking is placed at each end of the wall, adjacent to wall openings and 8' o.c. maximum. The blocking is attached to each adjacent stud via EasyClip™ E- or S- Series™ clips, or when a track is used, the flanges are cut, the web bent and a minimum 4" overlap is used to secure the track block to the studs. Strap bracing, 2" wide and 20ga (33 mils) minimum, is fastened to each solid block and stud flange.

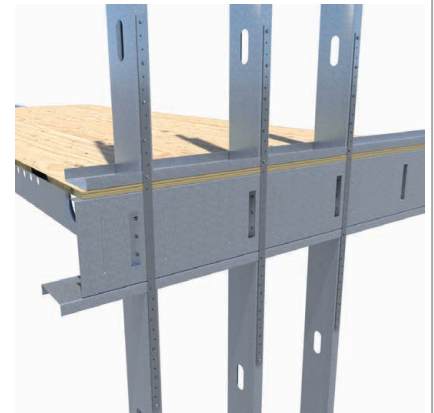

### Strap bridging for bottom of floor joists

Spacing of bridging must be calculated based on the required strength. In general, bridging is installed at a maximum of 8' o.c. spacing perpendicular to the joists. For example, an 18' joist span would require two bridging runs at 6' o.c. spacing. Where the sub-floor or decking does not provide lateral support, strap must also be installed on the top flange of the joist. Install immediately after joists are erected and before construction loads are applied. Solid blocking is field cut from track or joist sections.

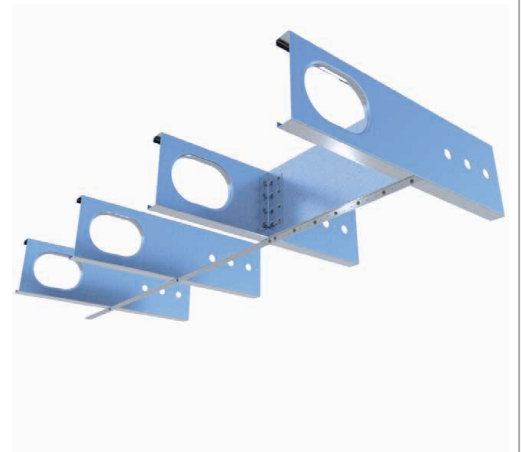

### Tension strapping for shear wall x-bracing

Straps are either attached directly to the compression studs or are attached via Gusset Plates. Compression studs must be anchored to the foundation, normally with ClarkDietrich Holdowns. For multi-story construction, the uplift loads are extremely high. It is not uncommon to require 20,000 to 40,000 pounds of uplift force at these connections. Since ClarkDietrich Holdowns are not designed to resist this magnitude of force, it is recommended that embedded plates be installed prior to pouring the concrete foundation. A heavy steel assembly is then welded to the embedded plate and to the compression studs.

Caution: Racking loads are first transferred to the roof or floor decking and then to the shearwalls (X-bracing). The X-bracing then relies on a proper foundation to resist uplift and shear forces. In order for the system to function properly, the load path from the roof or floor deck to the shearwalls to the foundation must be complete. This normally requires additional bracing, blocking, track and rim splices, drag struts, uplift anchors and heavy-duty foundations.



## Box Header Clip

Pre-punched clip for box header framing.

The Box Header Clip (BHC) is designed to eliminate field cutting metal track into sections. The BHC clip is pre-punched to promote a quick and accurate installation. It is available in a variety of sizes and thicknesses to accommodate different application requirements.

### MATERIAL SPECIFICATIONS

**Gauge:** 18 gauge (43mils)

**Design Thickness:** 0.0451 inches

**Gauge:** 16 gauge (54mils)

**Design Thickness:** 0.0566 inches

**Gauge:** 14 gauge (68mils)

**Design Thickness:** 0.0713 inches

**Material:** 50ksi, G90 (Z275) hot-dipped galvanized

**ASTM:** A1003, A653

### INSTALLATION

Refer to load tables for appropriate box header clip. All pre-punched holes must be filled by placing #10-16 screws to achieve noted capacities.

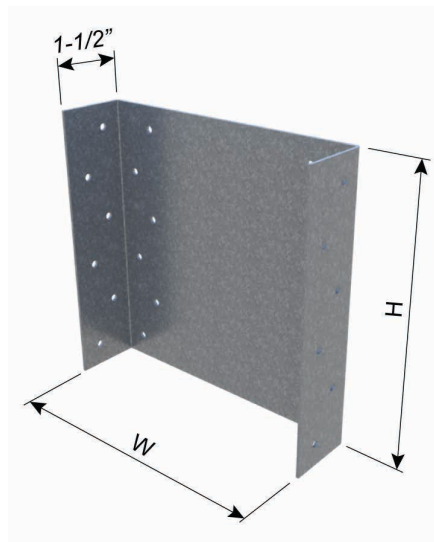

### Box Header Clip (BHC)

Product code	Width (W)	Height (H)
362BHC2	3-5/8"	2"
362BHC4		4"
362BHC6		6"
362BHC8		8"
362BHC10		10"
600BHC2	6"	2"
600BHC4		4"
600BHC6		6"
600BHC8		8"
600BHC10		10"
800BHC2	8"	2"
800BHC4		4"
800BHC6		6"
800BHC8		8"
800BHC10		10"



### Box Header Clip (BHC)

Product code	Head gauge (ga)	F2 (lbs.)				
		Jamb Gauge				
		20	18	16	14	12
XXXBHC2-43	20	353	353	353	353	353
	18	353	526	526	526	526
	16	353	526	839	839	839
	14	353	526	839	839	839
	12	353	526	839	839	839
XXXBHC2-54	20	353	353	353	353	353
	18	353	526	526	526	526
	16	353	526	933	933	933
	14	353	526	933	933	933
	12	353	526	933	933	933
XXXBHC2-68	20	353	353	353	353	353
	18	353	526	526	526	526
	16	353	526	933	933	933
	14	353	526	933	933	933
	12	353	526	933	933	933

Product code	Head gauge (ga)	F2 (lbs.)				
		Jamb Gauge				
		20	18	16	14	12
XXXBHC4-43	20	990	990	990	990	990
	18	990	1473	1473	1473	1473
	16	990	1473	2076	2076	2076
	14	990	1473	2076	2076	2076
	12	990	1473	2076	2076	2076
XXXBHC4-54	20	990	990	990	990	990
	18	990	1473	1473	1473	1473
	16	990	1473	2613	2613	2613
	14	990	1473	2613	2613	2613
	12	990	1473	2613	2613	2613
XXXBHC4-68	20	990	990	990	990	990
	18	990	1473	1473	1473	1473
	16	990	1473	2613	2613	2613
	14	990	1473	2613	2613	2613
	12	990	1473	2613	2613	2613

Product code	Head gauge (ga)	F2 (lbs.)				
		Jamb Gauge				
		20	18	16	14	12
XXXBHC6-43	20	1717	1717	1717	1717	1717
	18	1717	2555	2555	2555	2555
	16	1717	2555	3206	3206	3206
	14	1717	2555	3206	3206	3206
	12	1717	2555	3206	3206	3206
XXXBHC6-54	20	1717	1717	1717	1717	1717
	18	1717	2555	2555	2555	2555
	16	1717	2555	4533	4533	4533
	14	1717	2555	4533	4533	4533
	12	1717	2555	4533	4533	4533
XXXBHC6-68	20	1717	1717	1717	1717	1717
	18	1717	2555	2555	2555	2555
	16	1717	2555	4533	4533	4533
	14	1717	2555	4533	4533	4533
	12	1717	2555	4533	4533	4533

Product code	Head gauge (ga)	F2 (lbs.)				
		Jamb Gauge				
		20	18	16	14	12
XXXBHC8-43	20	2465	2465	2465	2465	2465
	18	2465	3668	3668	3668	3668
	16	2465	3668	4274	4274	4274
	14	2465	3668	4274	4274	4274
	12	2465	3668	4274	4274	4274
XXXBHC8-54	20	2465	2465	2465	2465	2465
	18	2465	3668	3668	3668	3668
	16	2465	3668	6509	6509	6509
	14	2465	3668	6509	6509	6509
	12	2465	3668	6509	6509	6509
XXXBHC8-68	20	2465	2465	2465	2465	2465
	18	2465	3668	3668	3668	3668
	16	2465	3668	6509	6509	6509
	14	2465	3668	6509	6509	6509
	12	2465	3668	6509	6509	6509

Product code	Head gauge (ga)	F2 (lbs.)				
		Jamb Gauge				
		20	18	16	14	12
XXXBHC10-43	20	2914	2914	2914	2914	2914
	18	2914	4336	4336	4336	4336
	16	2914	4336	5343	5343	5343
	14	2914	4336	5343	5343	5343
	12	2914	4336	5343	5343	5343
XXXBHC10-54	20	2914	2914	2914	2914	2914
	18	2914	4336	4336	4336	4336
	16	2914	4336	7694	7694	7694
	14	2914	4336	7694	7694	7694
	12	2914	4336	7694	7694	7694
XXXBHC10-68	20	2914	2914	2914	2914	2914
	18	2914	4336	4336	4336	4336
	16	2914	4336	7694	7694	7694
	14	2914	4336	7694	7694	7694
	12	2914	4336	7694	7694	7694



**Notes:**

- Listed capacities are based on AISI S100-16 (2020) w/S2-20, North American Specification for Cold-Formed Steel Structural Members, AISI D114-21, Cold-Formed Steel Clip Angle Design Guide, and AISI Research Report RP18-4.
- Capacities are based on #10-16 screws with an ultimate shear capacity of at least 1400 lbs.
- Capacities are based on #10-16 screws through all of the pre-punched holes in the connector to each side of the box header and #10-16 screws through all of the pre-punched holes in the connector to the jamb.
- Capacities are based on 20ga. and 18ga. 33ksi material and 16ga. and heavier 50ksi material.
- "XXX" = 362 for a 3-5/8" wall, 600 for a 6" wall, and 800 for an 8" wall.

## MEP Gusset Plate

Restores structural integrity of steel framing with field modified openings.

The MEP Gusset Plate is designed to provide strength and stiffness to framing members that are modified or field cut at the job site with oversized cutouts on the web of the member. The two-piece design allows the plate to be attached after MEP components have been installed.

- For use with 15mil to 97mil framing members.
- Not for use when flange is cut out.

### PRODUCT DIMENSIONS

MEP3 = 3-1/2" x 8" assembled

MEP6 = 5-3/4" x 8" assembled

### MATERIAL SPECIFICATIONS

**Gauge:** 16 gauge (54mil)

**Design Thickness:** 0.0566 inches

**Material:** 50ksi, G90 (Z275) hot-dipped galvanized

### INSTALLATION

Installing the ClarkDietrich MEP Gusset Plate in accordance with the following guidelines will return the stud member to its original flexural strength, shear strength, and stiffness.

- The dimensions of the field cut hole shall be no greater than 3" wide by 3" tall for 6" framing members and 2" wide by 3" tall for 3-5/8" members.
- Field cut holes shall be made with a plasma cutter or saw. Torch-cut holes are not permitted.
- The steel around the hole shall not be damaged or distorted.
- A total of (12) #10-16 screws shall be used at each hole repair location as shown in the figure.
- This product cannot be used when framing member's flange is notched.
- Minimum stud web hole spacing shall be maintained for compliance with AISI S100, S220 & S240 standards.
- The axial capacity and web crippling capacity of the stud member shall be considered separately. It is the responsibility of the design professional to verify that the capacity meets the requirements of the intended application.

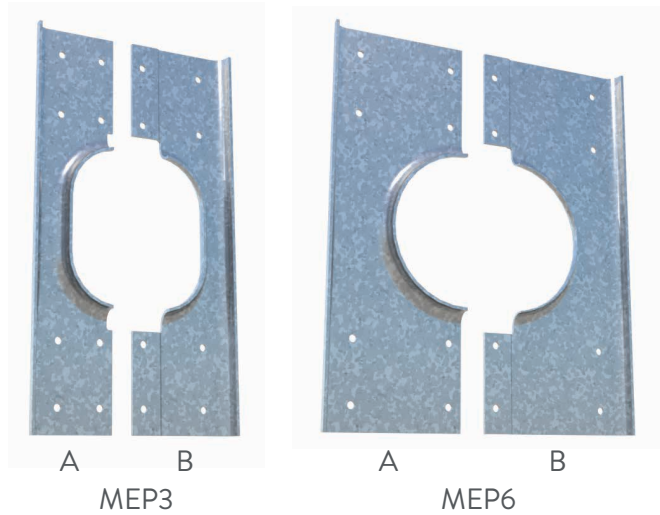

### MEP Gusset Plate (MEP)

Product code	Dimensions (assembled)	Packaging
MEP3	3-1/2" x 8"	25 Sets (A&B)
MEP6	5-3/4" x 8"	25 Sets (A&B)

THIS PAGE LEFT INTENTIONALLY BLANK.

Product Detail

Visit our CAD Library at [clarkdietrich.com](http://clarkdietrich.com) to view or download construction details in .dwg, .dxf, and .pdf formats.

BRIDGING DETAILS

Spazzer® 9200 Bridging

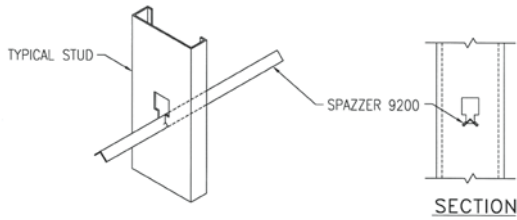

Spazzer 5400 Bridging

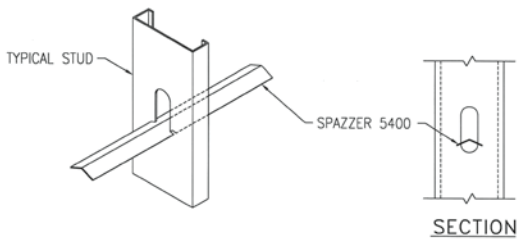

U-Channel Bridging Connection

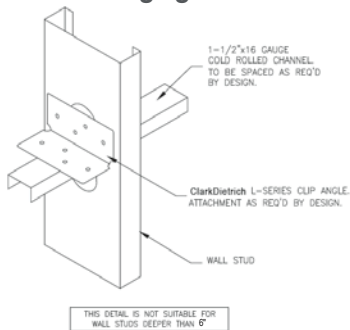

Block and Strap Bridging

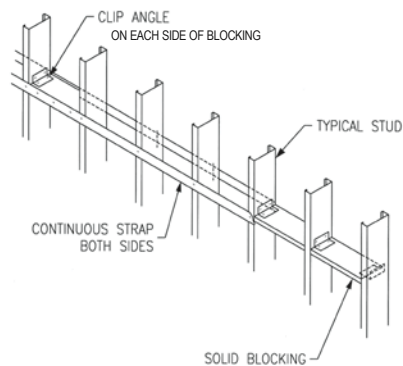

HEADER DETAILS

Curtain Wall RedHeader PRO™ Header & Jamb

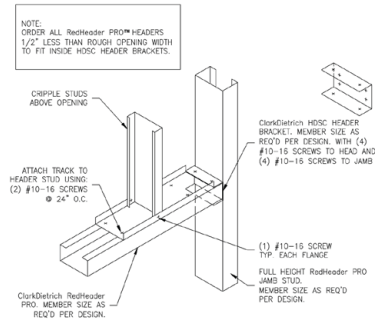

Curtain Wall HDS® Header & Jamb

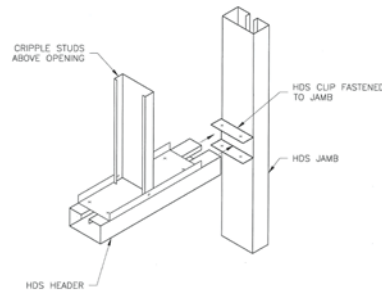

Load-Bearing HDS Header & Jamb

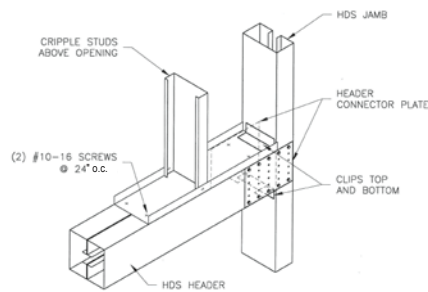

HEAD-OF-WALL DEFLECTION DETAILS

Long Leg Track with Spazzer 5400

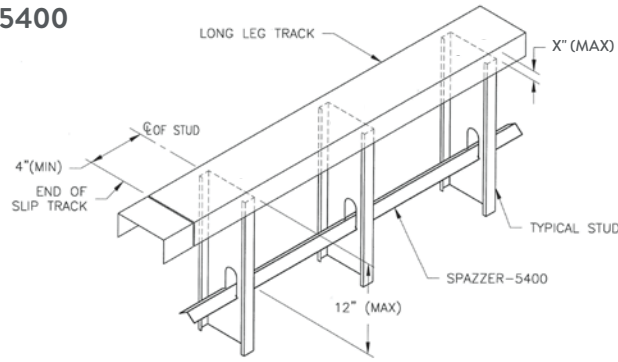

Long Leg Track with U-Channel

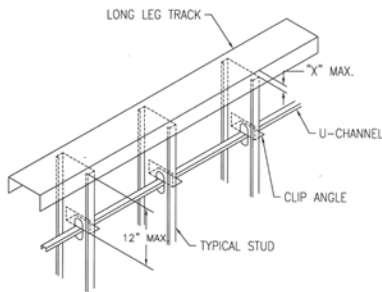

Double Track™

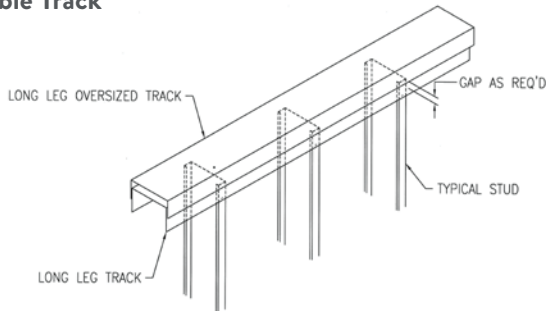

Long Leg Track with Fast Top™ Clip

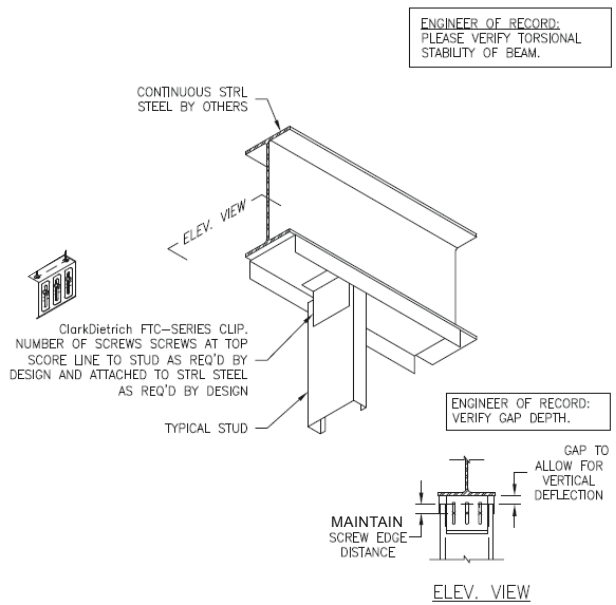

Details shown in this brochure are for example only. The engineer of record on the project is responsible for the design of the connection to the structure. Additional connection details can be found at [clarkdietrich.com](http://clarkdietrich.com).

## PRODUCT NAME INDEX

2x6 FR Blocking ..... 160-161  
 5400 Spazzer® Spacer Bar ..... 149-153  
 9200 Spazzer Spacer Bar ..... 148

**A**

Aluminum Burn Clip ..... 176  
 A-Series™ End Clip ..... 92-93  
 Anchor Clip D-Series™ ..... 94-95  
 ASTM ..... 199

**B**

Backer Bar ..... 158  
 BlazeFrame® Shield ..... 159  
 Box Header Clip ..... 190-191  
 Bridging, Bracing and Backing ..... 138-161  
 Bridging Details ..... 194  
 Bridging Termination Clip ..... 144-145  
 Bridle Hanger ..... 122-123

**C**

CC33 ¾" Channel Clip ..... 142-143  
 ClarkDietrich Holdown ..... 100-103  
 ClarkDietrich Moment Clip ..... 108-109  
 ClarkDietrich Seismic & Hurricane Clips ..... 164-165  
 ClarkDietrich Skewable Angle ..... 128-129  
 ClarkDietrich Sound Clip ..... 178-183  
 Clip Angle U-Series™ ..... 89  
 Clip Angle X-Series™ ..... 146-147  
 Clip Express™ Display Program ..... 198  
 Code Approvals ..... 199  
 Commercial Strapping ..... 188-189  
 Custom Clips ..... 2-3

**D**

D-Blaze® ..... 156-157  
 D-Series™ Anchor Clip ..... 94-95  
 Danback® Flexible Wood Backing Plate ..... 156-157  
 Deflection Connections ..... 12-43  
 Drift Connections ..... 44-71  
 Drift FastClip™ Slide Clip ..... 46-49  
 Drift Head-of-Wall ..... 50-53  
 Drift Rail and Clip ..... 54-71  
 Drift Headed Rail and Clip ..... 54-71

**E**

E-Series™ Support Clip ..... 136-137  
 EasyClip™ A-Series™ End Clip ..... 92-93  
 EasyClip D-Series™ Anchor Clip ..... 94-95  
 EasyClip E-Series™ Support Clip ..... 136-137  
 EasyClip S-Series™ Support Clip ..... 90-91  
 EasyClip T-Series™ Tall Anchor Clip ..... 94-95  
 EasyClip U-Series™ Clip Angle ..... 89  
 EasyClip X-Series™ Clip Angle ..... 146-147  
 EasyClip QuickTwist™ Web Stiffener ..... 134-135  
 End Clip A-Series ..... 92-93  
 Engineering Services ..... 11  
 Extended FastClip™ Slide Clip ..... 17-19  
 Extended LE-Series™ Support Clip ..... 88  
 Extended Uni-Clip™ ..... 76-77  
 Extended Uni-Clip™ w/Anchor Holes ..... 78-79

**F**

Fast Strut™ ..... 40-41  
 Fast Top™ Clip ..... 28-30  
 FastBack™ Backing System ..... 155  
 FastBridge™ Clip ..... 96-97, 140-141  
 FastClip™ Slide Clip ..... 14-16  
 FastClip™ Slide Clip w/Anchor Holes ..... 20-21  
 Fastening Options ..... 4-6  
 Field Skewable TradeReady® Splice Plate ..... 130-131  
 Fixed Universal Slip Clip ..... 42-43, 118-119  
 FlamePRO® Fire Retardant ..... 156-157  
 Flat Tail™ Slide Clip ..... 31-39

Floor Framing Connections ..... 120-137  
 FR Blocking ..... 160-161  
 Furring Clip ..... 185

**G**

G-Series™ Punched Gusset Plate ..... 168-169  
 Gauge ..... 10  
 General Notes ..... 7  
 GP-Series™ Unpunched Gusset Plate ..... 166-167  
 Green Building ..... 197  
 Grommets ..... 177  
 Gusset Plate for Shearwall Bracing ..... 166-167  
 Gusset Plates ..... 166-169

**H**

H-Series™ Universal Header Hanger ..... 98-99  
 HDSC Header Bracket ..... 172-175  
 Head-of-Wall ..... 28-30, 50-53  
 Head-of-Wall Deflection Details ..... 195  
 Header Cripple Stud Clip ..... 184  
 Header Details ..... 194  
 Header Hanger ..... 98-99  
 Headers ..... 172-175  
 Holdown ..... 100-103  
 Holdown Plate ..... 104-107  
 How to Use This Catalog ..... 8-9  
 Hurricane Clip ..... 164-165

**I**

—

**J**

—

**K**

ksi ..... 10

**L**

L-Series™ Support Clip ..... 86-87  
 LA-Series™ Support Clip ..... 86-87  
 LE-Series™ Support Clip ..... 88  
 LS-Series™ Support Clip ..... 86-87  
 LEED® ..... 199  
 Load Tables ..... 9  
 Locations ..... 199

**M**

Material Certification ..... 197  
 MEP Gusset Plate ..... 192  
 Metal Furring Channel Clip ..... 185  
 Metal Thickness ..... 10  
 Metric Specifications ..... 10  
 Moment Clip ..... 108-109

**N**

—

**O**

—

**P**

Packaging ..... 10  
 Panel Lift Clip ..... 186-187  
 Performance Standards ..... 197  
 Pony Wall Heavy ..... 110-113  
 Pony Wall Light ..... 114-117  
 Powder-Actuated Fasteners ..... 5  
 Product Detail ..... 194-195  
 Product Information ..... 10  
 Product Labeling ..... 10  
 Product Warranty ..... 198  
 Proprietary Deflection Screw .....  
 4, 14, 17, 20, 28, 31, 40, 43, 46-47, 48-49, 55  
 Protective Coatings ..... 10

**Q**

QuickTwist™ Web Stiffener ..... 134-135

**R**

Rafter Connections ..... 130-131, 164-165, 166-167  
 Recycled Content ..... 197  
 Rigid Connections ..... 72-119  
 Roof and Truss Connections ..... 162-169

**S**

S-Series™ Support Clip ..... 90-91  
 Safety Warning ..... 7  
 Sales ..... 199  
 Screw Connections ..... 4  
 Seismic Clip ..... 164-165  
 Shop Drawings ..... 194-195  
 Skewable Angle ..... 128-129  
 Sound Clip ..... 178-183  
 Spazzer® 5400 Spacer Bar ..... 149-153  
 Spazzer® 9200 Spacer Bar ..... 148  
 Spazzer® Bar Fly Clip ..... 154  
 Spazzer® Bar Guard™ ..... 149  
 Spazzer® Snap-In Grommet ..... 149  
 Special Order Connections ..... 2-3  
 Specialty Clips, Accessories ..... 170-193  
 Specification Options ..... 10  
 Splice Plate ..... 130-131  
 Standards and Specifications ..... 10  
 Steel Thickness ..... 10  
 Support Clip E-Series™ ..... 136-137  
 Support Clip L-Series™ ..... 86-87  
 Support Clip S-Series™ ..... 90-91  
 SwiftClip™ L-Series™ Support Clip ..... 86-87

**T**

T-Series™ Tall Anchor Clip ..... 94-95  
 Tall Anchor Clip T-Series ..... 94-95  
 Technical Assistance ..... 11, 199  
 Technical Services ..... 11  
 Trademarks ..... 198  
 TradeReady Floor Joist Blocking ..... 132  
 TradeReady® Splice Plate ..... 130-131  
 TradeReady Structural Bridging ..... 133  
 Truss Holdowns ..... 130-131, 164-165, 166-169  
 Typical Construction Details ..... 194-195

**U**

U-Series™ Clip Angle ..... 89  
 Understanding Load Tables ..... 9  
 Uni-Clip™ End Clip ..... 74-75  
 Universal Bypass Clip ..... 22-27, 80-85  
 Universal Joist Hanger ..... 124-126

**V**

—

**W**

Warranty ..... 198  
 Web Stiffener ..... 134-135  
 Weld Types ..... 6  
 Welded Connections ..... 6

**X**

X-Series™ Clip Angle ..... 146-147

**Y**

Yield Strength ..... 10

**Z**

—



## PRODUCT CODE INDEX

**A**

A543 ..... 92-93  
 A546 ..... 92-93  
 A683 ..... 92-93  
 A686 ..... 92-93  
 A973 ..... 92-93  
 A976 ..... 92-93  
 AB ..... 176  
 AB30 ..... 176  
 AB35 ..... 176  
 AB40 ..... 176  
 AB45 ..... 176  
 AB63 ..... 176

**B**

BB12 ..... 158  
 BB16 ..... 158  
 BB24 ..... 158  
 BHC ..... 190-191  
 BTC ..... 144-145

**C**

CC33 ..... 142-143  
 CD8-B ..... 100-103  
 CD10-B ..... 100-103  
 CD15-B ..... 100-103  
 CD8-S ..... 100-103  
 CD10-S ..... 100-103  
 CD15-S ..... 100-103  
 CDBV ..... 122-123  
 CDMB ..... 122-123  
 CDSC ..... 178-183  
 CS ..... 188-189

**D**

D16C ..... 156-157  
 D16F ..... 156-157  
 D24C ..... 156-157  
 D24F ..... 156-157  
 D683 ..... 94-95  
 D685 ..... 94-95  
 D973 ..... 94-95  
 D975 ..... 94-95  
 D-FCSC ..... 46-49  
 DHOW ..... 50-53  
 DHR ..... 54-71  
 DRC ..... 54-71

**E**

E541 ..... 136-137  
 E543 ..... 136-137  
 E545 ..... 136-137  
 E547 ..... 136-137  
 E549 ..... 136-137  
 E681 ..... 136-137  
 E683 ..... 136-137  
 E685 ..... 136-137  
 E687 ..... 136-137  
 E689 ..... 136-137  
 E971 ..... 136-137  
 E973 ..... 136-137  
 E975 ..... 136-137  
 E977 ..... 136-137  
 E979 ..... 136-137

**F**

FB33 ..... 96-97, 140-141  
 FB43 ..... 96-97, 140-141  
 FB68 ..... 96-97, 140-141  
 FBBC ..... 155  
 FBW ..... 155

FCEC 6 ..... 17-19  
 FCEC 8 ..... 17-19  
 FCEC 10 ..... 17-19  
 FCEC 12 ..... 17-19  
 FCSC 3-1/2 ..... 14-16  
 FCSC 5-1/2 ..... 14-16  
 FCSC-HD ..... 20-21  
 FRB26-16 ..... 160-161  
 FS12 ..... 40-41  
 FS15 ..... 40-41  
 FS18 ..... 40-41  
 FS20 ..... 40-41  
 FS22 ..... 40-41  
 FS24 ..... 40-41  
 FS316, FS324 ..... 159  
 FS416, FS424 ..... 159  
 FS616, FS624 ..... 159  
 FTC3 ..... 28-30  
 FTC5 ..... 28-30  
 FTC8 ..... 28-30  
 FTC10 ..... 28-30  
 FTC12 ..... 28-30  
 FTSC ..... 31-39  
 FUS6 ..... 42-43, 118-119  
 FUS8 ..... 42-43, 118-119

**G**

G436 ..... 168-169  
 G546 ..... 168-169  
 G686 ..... 168-169  
 GP ..... 166-167  
 GROM 3/4 ..... 177  
 GROM 1-1/2 ..... 177

**H**

H436 ..... 98-99  
 H546 ..... 98-99  
 H686 ..... 98-99  
 HC2 ..... 164-165  
 HC2A ..... 164-165  
 HC2.5 ..... 164-165  
 HC3 ..... 164-165  
 HDP ..... 104-107  
 HDSC 3-1/2 ..... 172-175  
 HDSC 3-7/8 ..... 172-175  
 HDSC 5-7/8 ..... 172-175  
 HDSC 7-7/8 ..... 172-175

**I**

—

**J**

JB ..... 132

**K**

—

**L**

LA543 ..... 86-87  
 LA545 ..... 86-87  
 LA547 ..... 86-87  
 LA683 ..... 86-87  
 LA685 ..... 86-87  
 LA687 ..... 86-87  
 LA973 ..... 86-87  
 LA975 ..... 86-87  
 LA977 ..... 86-87  
 LE543 ..... 86-87  
 LE545 ..... 86-87  
 LE547 ..... 86-87  
 LE683 ..... 86-87  
 LE685 ..... 86-87

LE687 ..... 86-87  
 LE6816 ..... 88  
 LE6818 ..... 88  
 LE6820 ..... 88  
 LE6824 ..... 88  
 LE6830 ..... 88  
 LE6836 ..... 88  
 LE973 ..... 86-87  
 LE975 ..... 86-87  
 LE977 ..... 86-87  
 LGPW ..... 114-117  
 LS541 ..... 86-87  
 LS5413 ..... 86-87  
 LS543 ..... 86-87  
 LS545 ..... 86-87  
 LS547 ..... 86-87  
 LS549 ..... 86-87  
 LS681 ..... 86-87  
 LS6813 ..... 86-87  
 LS683 ..... 86-87  
 LS685 ..... 86-87  
 LS687 ..... 86-87  
 LS689 ..... 86-87  
 LS971 ..... 86-87  
 LS9713 ..... 86-87  
 LS973 ..... 86-87  
 LS975 ..... 86-87  
 LS977 ..... 86-87  
 LS979 ..... 86-87

**M**

MC103P ..... 108-109  
 MC105P ..... 108-109  
 MC107P ..... 108-109  
 MC683P ..... 108-109  
 MC685P ..... 108-109  
 MC687P ..... 108-109  
 MC973P ..... 108-109  
 MC975P ..... 108-109  
 MC977P ..... 108-109  
 MEP3 ..... 192  
 MEP6 ..... 192  
 MFCC ..... 185

**N**

—

**O**

—

**P**

PLC8 ..... 186-187  
 PLC12 ..... 186-187  
 PW ..... 110-113

**Q**

QTWS ..... 134-135

**R**

RCSC ..... 184

**S**

S541 ..... 90-91  
 S543 ..... 90-91  
 S545 ..... 90-91  
 S547 ..... 90-91  
 S549 ..... 90-91  
 S681 ..... 90-91  
 S683 ..... 90-91  
 S685 ..... 90-91  
 S687 ..... 90-91  
 S689 ..... 90-91

S971 ..... 90-91  
 S973 ..... 90-91  
 S975 ..... 90-91  
 S977 ..... 90-91  
 S979 ..... 90-91  
 SA3 ..... 128-129  
 SA4 ..... 128-129  
 SA5 ..... 128-129  
 SA6 ..... 128-129  
 SA7 ..... 128-129  
 SA9 ..... 128-129  
 SFLY ..... 154  
 SPBG ..... 149  
 SPGR ..... 149  
 SPZD ..... 148  
 SPZS ..... 149-153

**T**

T683 ..... 94-95  
 T685 ..... 94-95  
 T973 ..... 94-95  
 T975 ..... 94-95  
 TDSB ..... 133  
 TDSP ..... 130-131

**U**

U543 ..... 89  
 U545 ..... 89  
 U547 ..... 89  
 U549 ..... 89  
 U683 ..... 89  
 U685 ..... 89  
 U687 ..... 89  
 U689 ..... 89  
 U973 ..... 89  
 U975 ..... 89  
 U977 ..... 89  
 U979 ..... 89  
 UBC ..... 22-27, 80-85  
 UCEC ..... 74-75  
 UJH ..... 124-126  
 UXRC6 ..... 76-77  
 UXRC6-HD ..... 78-79  
 UXRC8 ..... 76-77  
 UXRC10 ..... 76-77  
 UXRC12 ..... 76-77

**V**

—

**W**

—

**X**

X543 ..... 146-147  
 X545 ..... 146-147  
 X547 ..... 146-147  
 X549 ..... 146-147  
 X683 ..... 146-147  
 X685 ..... 146-147  
 X687 ..... 146-147  
 X689 ..... 146-147  
 X973 ..... 146-147  
 X975 ..... 146-147  
 X977 ..... 146-147  
 X979 ..... 146-147

**Y**

—

**Z**

—

## Clip Express<sup>SM</sup> Display Program



### CLARKDIETRICH CLIP EXPRESS<sup>SM</sup> PRODUCT DISPLAYS

ClarkDietrich is committed to providing the product data, application details and hands-on tools necessary to help our customers select the best part for a specific design challenge.

For those dealers willing to commit resources to a stocking program for ClarkDietrich clip products, we offer the opportunity for the co-op development of Clip Express Product Displays. These displays provide dealers and contractors with the opportunity to visualize how many of our products can be used in a variety of applications. For more information, please contact the Clip Express sales team:

Clip Express—866.638.1908

## Trademarks and Warranty

### PATENTS

U.S. Patent Nos. 6,021,618; 6,688,069; D814,905; D822,455 are owned by ClarkDietrich

U.S. Patent No. 7,882,676 is owned by Jeffrey Thomas Ellis

U.S. Patent No. 6,705,056 is owned by Kathy Tollenaar

### TRADEMARKS

ClarkDietrich<sup>®</sup> is a registered trademark of ClarkDietrich Building Systems.

Owned trademarks by ClarkDietrich Building Systems:  
 ProSTUD<sup>®</sup>, TRAKLOC<sup>®</sup>, TradeReady<sup>®</sup>, Spazzer<sup>®</sup>, FastClip<sup>™</sup>, EasyClip<sup>™</sup>, Fast Top<sup>™</sup>, Fast Strut<sup>™</sup>, FastBridge<sup>™</sup>, Uni-Clip<sup>™</sup>, Clip Express<sup>SM</sup>, Stronger Than Steel<sup>SM</sup>, FastBack<sup>™</sup>, HDS<sup>®</sup>, RedHeader PRO<sup>™</sup>, QuickTwist<sup>™</sup>, Slide Clip<sup>™</sup>, SubmittalPro<sup>®</sup>, SwiftClip<sup>™</sup>, A-Series<sup>™</sup>, D-Series<sup>™</sup>, E-Series<sup>™</sup>, G-Series<sup>™</sup>, GP-Series<sup>™</sup>, H-Series<sup>™</sup>, L-Series<sup>™</sup>, LS-Series<sup>™</sup>, LE-Series<sup>™</sup>, LA-Series<sup>™</sup>, S-Series<sup>™</sup>, T-Series<sup>™</sup>, U-Series<sup>™</sup>, X-Series<sup>™</sup>, MaxTrak<sup>®</sup>, Bar Guard<sup>™</sup>, DoubleTrack<sup>™</sup> QC-Series<sup>™</sup>, BackerBead<sup>®</sup>, ClarkDietrich Wall Type Creator<sup>®</sup>, DiamondPlus<sup>®</sup> and ClarkDietrich Sound Clip<sup>™</sup>.

U.S. Patent No. D820,664 owned by Allen Innovations, LLC

**Buildex<sup>®</sup>** is a registered trademark of Illinois Tool Works, Inc.

**D-Blaze<sup>®</sup>** is a registered trademark of Viance, LLC

**FlamePro<sup>®</sup>** is a registered trademark of Koppers Performance Chemicals, Inc.

**LEED<sup>®</sup>** is a registered trademark of the U.S. Green Building Council

**Danback<sup>®</sup>** is a registered trademark of Kathy Tollenaar

**UL<sup>®</sup> and UL Design<sup>®</sup>** are trademarks of Underwriter's Laboratories, Inc.

**Hilti** is a registered trademark of Hilti Aktiengesellschaft Corporation

### WARRANTY

Our products are manufactured in accordance with company standards and/or industry standards, as applicable. All ClarkDietrich Building Systems products are covered by our standard warranty which is contained in our Standard Terms and Conditions of Sale and which will be provided upon request. Generally, we warrant our products will be free from defects in material and workmanship at the time of shipment, subject to the limitations stated in the warranty. Unless specifically agreed in writing by us with respect to specific orders, we do not make any warranty of merchantability or fitness for a particular purpose. The buyer is responsible to assure that buyer orders the appropriate product for any applicable code or specification requirements.

**NOTICE:** Our liability is expressly limited to replacement of defective products. We shall not be liable for incidental and consequential damages, nor for any loss caused by misuse or misapplication of our products. Any claim shall be deemed waived unless made in writing to us within thirty (30) days from the date it was or reasonably should have been discovered.

# Clip Express<sup>SM</sup> CODE APPROVALS AND PERFORMANCE STANDARDS

ClarkDietrich Clip Express products meet or exceed these applicable performance standards.

## ClarkDietrich Clip & Connector Standards

AISI S100-16 (2020) w/S2-20 - North American Specification for the Design of Cold-Formed Steel Structural Members

AISI S240-20 - North American Standard for Cold-Formed Steel Structural Framing

ClarkDietrich Nonstructural Framing comply with:

2021 International Building Code

Intertek CCRR-0208 - FastClip™ / Universal Bypass Clip

SFIA (Steel Framing Industry Association) Connector Code Compliance Certification Program

## LEED® Services BUILD GREEN with ClarkDietrich

ClarkDietrich is an active member of the U.S. Green Building Council and is committed to supplying quality products that are environmentally responsible. We are continually working to develop greener building products and sustainable business practices. ClarkDietrich steel framing helps contribute points toward LEED® certification. For more details contact Technical Services at 888-437-3244 or visit [www.clarkdietrich.com/LEED](http://www.clarkdietrich.com/LEED).

## SustainabilityPro

Quickly access the product-specific information and certifications needed to calculate contributions to LEED® and other green building certification and rating systems - all in one platform. Find out more at [www.clarkdietrich.com/LEED](http://www.clarkdietrich.com/LEED).

ClarkDietrich has prepared this literature with the utmost diligence and care for accuracy and conformance to standards.

ClarkDietrich intends this information to be accurate, informative, and helpful as a selection guide for choosing ClarkDietrich products. However, this information is only to be used for guidance and is not intended to replace the design, drawings, specifications, and decisions of a professional architect or engineer.

ClarkDietrich or its affiliates shall not be responsible for incidental or consequential damages, directly or indirectly sustained, nor for loss caused by application of our products for other than their intended uses. Our liability is limited to replacement of defective products. Claims shall be deemed waived unless they are made to us in writing within thirty (30) days of the date a problem was or reasonably should have been discovered.

ClarkDietrich reserves the right to modify or change any information contained in this literature without notification.

ClarkDietrich is a proud member of the Steel Framing Industry Association (SFIA). Check the updated list of Certified Production Facilities at Intertek's website at [www.intertek.com](http://www.intertek.com).



USGBC and related logo is a trademark owned by the U.S. Green Building Council and is used by permission.

## LOCATIONS

### ClarkDietrich Manufacturing and Sales Locations:

**CALIFORNIA** Riverside  
P 951.360.3500

**CALIFORNIA** Sacramento  
P 951.360.3500

**CONNECTICUT** Bristol  
P 866.921.0023

**FLORIDA** Dade City  
P 352.518.4400

**FLORIDA**, Miami  
P 305.477.6464

**GEORGIA** McDonough  
P 678.304.5500

**ILLINOIS** Rochelle  
P 800.659.0745

**MARYLAND** Baltimore  
P 410.477.4000

**MISSOURI** O'Fallon  
P 636.300.1411

**OHIO** Warren-East  
P 330.372.5564

**OHIO** Vienna  
P 330.372.4014

**TEXAS** Dallas  
P 214.350.1716

**TEXAS** Pasadena  
P 281.383.1617

**CLIP EXPRESS<sup>SM</sup>** P 866.638.1908  
Dallas McDonough  
Warren Sacramento

### ClarkDietrich Engineering Services. A full spectrum of solutions.

Toll-Free Phone: 877.832.3206  
Toll-Free Fax: 877.832.3208  
Technical Services: 888.437.3244  
Email: [engineering@clarkdietrich.com](mailto:engineering@clarkdietrich.com)

**CENTRAL** Merrillville, IN  
**NORTHEAST** Bristol, CT

**SOUTHEAST** McDonough, GA  
**WEST** Carlsbad, CA

Turn to ClarkDietrich for a complete lineup of steel construction products and services nationwide:

Interior Framing · Exterior Framing · Interior Finishing · Exterior Finishing · Clips/Connectors · Engineering



ClarkDietrich.

9050 Centre Pointe Dr. Suite 400  
West Chester, OH 45069

P 513.870.1100  
F 513.870.1300

[clarkdietrich.com](http://clarkdietrich.com)  
Clarkwestern Dietrich Building Systems LLC