

UU-B-790a
February 5, 1968
SUPERSEDING
Fed. Spec. UU-B-790
July 9, 1964

FEDERAL SPECIFICATION

BUILDING PAPER, VEGETABLE FIBER:

(KRAFT, WATERPROOFED, WATER REPELLENT
AND FIRE RESISTANT)

This specification was approved by the Commissioner, Federal Supply Service, General Services Administration, for the use of all Federal agencies.

1. SCOPE AND CLASSIFICATION

1.1 Scope. This specification covers building papers composed predominantly of sulphate pulp fibers.

1.2 Classification.

1.2.1 Types, grades, and styles. The building papers shall be of the following types, grades, and styles, as specified (see 6.2):

- Type I - Barrier paper.
 - Grade A - High water-vapor resistance.
 - Grade B - Moderate water-vapor resistance.
 - Grade C - Water resistant.
 - Grade D - Water-vapor permeable.
 - Style 1a - Uncreped, not reinforced.
 - Style 1b - Uncreped, not reinforced, red rosin sized.
 - Style 2 - Uncreped, not reinforced, saturated.
 - Style 3 - Creped one direction, not reinforced.
 - Style 4 - Uncreped, reinforced.
 - Style 5 - Creped one direction, reinforced.
 - Style 6 - Creped two directions, not reinforced.
 - Style 7 - Creped two directions, reinforced.
- Type II - Concrete-curing paper.
 - Grade E - Moisture retentive.
 - Style 8 - Regular color, reinforced.
 - Style 9 - White, reinforced.
- Type III - Fire-resistant paper.
 - Grade F - Water repellent.
 - Style 10 - 56-pound paper.
- Type IV - Insulation tape paper.
 - Grade G - High tensile strength - water resistant.
 - Style 11 - Reinforced.

FSC 5640

UU-B-790a

2. APPLICABLE DOCUMENTS

2.1 Specifications and standards. The following specifications and standards, of the issues in effect on date of invitation for bids or request for proposal, form a part of this specification to the extent specified herein:

Federal Specifications:

UU-P-31 - Paper; General Specifications and Methods of Testing.
PPP-B-601 - Boxes, Wood, Cleated-Plywood.
PPP-B-1055 - Barrier Material, Waterproofed, Flexible.
PPP-T-60 - Tape: Pressure-Sensitive Adhesive, Waterproof,
for Packaging.

Federal Standard:

Fed. Std. No. 123 - Marking for Domestic Shipment (Civilian Agencies).

(Activities outside the Federal Government may obtain copies of Federal Specifications, Standards, and Handbooks as outlined under General Information in the Index of Federal Specifications and Standards and at the prices indicated in the Index. The Index, which includes cumulative monthly supplements as issued, is for sale on a subscription basis by the Superintendent of Documents, U.S. Government Printing Office, Washington, D. C. 20402.

(Single copies of this specification and other product specifications required by activities outside the Federal Government for bidding purposes are available without charge at the General Services Administration Regional Offices in Boston, New York, Washington, D. C., Atlanta, Chicago, Kansas City, Mo., Fort Worth, Denver, San Francisco, Los Angeles, and Seattle, Wash.

(Federal Government activities may obtain copies of Federal Specifications, Standards, and Handbooks and the Index of Federal Specifications and Standards from established distribution points in their agencies.)

Military Standards:

MIL-STD-105 - Sampling Procedures and Tables for Inspection by
Attributes.
MIL-STD-129 - Marking for Shipment and Storage.

(Copies of Military Specifications and Standards required by contractors in connection with specific procurement functions should be obtained from the procuring activity or as directed by the contracting officer.)

2.2 Other publications. The following documents form a part of this specification to the extent specified herein. Unless otherwise indicated, the issue in effect on date of invitation for bids or request for proposal shall apply.

American Society for Testing and Materials (ASTM) Publications:

C 156 - Water Retention Efficiency of Liquid Membrane-Forming Compounds and Impermeable Sheet Materials for Curing Concrete.

D 777 - Flammability of Treated Paper and Paperboard.

(Application for copies should be addressed to the American Society for Testing and Materials, 1916 Race Street, Philadelphia, Pa. 19103.)

American Trucking Associations, Inc.:

National Motor Freight Classification Rules.

(Application for copies should be addressed to the American Trucking Associations, Inc., 1616 P Street, N. W., Washington, D. C. 20036.)

Uniform Classification Committee:

Uniform Freight Classification Rules.

(Application for copies should be addressed to the Uniform Classification Committee, 202 Union Station, 516 West Jackson Boulevard, Chicago, Ill. 60606.)

Technical society and technical association specifications and standards are generally available for reference from libraries. They are also distributed among technical groups and using Federal agencies.

3. REQUIREMENTS

3.1 Description. The paper shall be either a single-ply or a multi-ply lamination, and shall be furnished in continuous one-piece rolls. Not more than one splice within a roll shall be permitted and the bond of the splice shall be equal to or greater than the strength of the paper.

3.2 Initial production. When specified (see 6.2), the supplier shall furnish to the Government one or more rolls of building paper for testing as specified in 4.3.

3.3 Material. Material shall be as specified herein. Materials not specified shall be selected by the supplier and shall be subject to all provisions of this specification.

3.3.1 Paper. The paper shall consist of 100 percent sulphate pulp fibers, free of ground wood pulp, except as permitted in 3.6.7.

3.4 Construction. Lapped papers shall be securely cemented together throughout the seam area and shall have a minimum lap of 4 inches. Laminated paper shall contain no area of more than 1/2 inch, measured from the longitudinal edge of the combined sheet, which is devoid of the laminating agent. The paper shall not stick together to such an extent as to cause tearing when unrolled.

3.4.1 Treatment. The paper shall be treated by the addition of asphalt, asphalt waxes, wax blends, wet-strength resins, rosins, fire-retarding salts or any combining agent, to impart the necessary characteristics to the paper.

UU-B-790a

3.4.2 Reinforcing. When reinforcing is specified herein, the paper shall be reinforced by imbedding cords or strands of vegetable or inorganic fibers in the combining agent of the lamination.

3.5 Sizes. The paper shall be furnished in continuous, one-piece rolls of the widths and lengths or areas shown in table I, as specified (see 6.2).

TABLE I. Roll sizes

Roll widths	Type I	Type II	Type III	Type IV
6 in.	-	-	-	x
18 in.	-	x	-	-
24 in.	-	x	-	-
36 in.	x	x	x	-
40 in.	x	-	x	-
48 in.	x	x	-	-
54 in.	-	x	-	-
60 in.	x	x	-	-
72 in.	x	x	-	-
84 in.	x	x	-	-
96 in.	x	x	-	-
8 to 26-1/2 ft.	-	x	-	-

Roll area or roll length	Type I	Type II	Type III	Type IV
150 sq.ft.	-	-	-	x
250 sq.ft.	x	-	-	-
300 sq.ft.	-	x	-	-
500 sq.ft.	x	-	-	-
750 sq.ft.	-	-	x	-
1,000 sq.ft.	x	-	-	-
75-ft long [1]	-	x	-	-
60-ft long [2]	-	x	-	-

[1] For rolls 20 ft or less in width.

[2] For rolls over 20 ft in width.

3.6 Type I, Barrier paper. Except for style 2, the paper shall not crack when bent over a 1/16-inch mandrel at the temperature of 32 deg. F. If reinforced, the cords or strands shall average not less than 10 per foot in each direction.

3.6.1 Grade A, High water-vapor resistant. Grade A paper shall have the dry tensile strength, water-resistance, and water-vapor permeability properties shown in table II.

TABLE II. Grade requirements

Physical property requirement	Grade						
	A	B	C	D	E	F	G
Dry tensile strength; min., lb per in. width: both directions...	[1]	[1]	[1]	20	-	-	85
Wet tensile strength; min., lb per in. width:							
machine direction.....	-	-	-	-	30	-	-
cross direction.....	-	-	-	-	15	-	-
Water resistance:							
hours min.....	24	16	8	1/6	-	-	24
water loss, max., grams per sq. centimeter of surface.....	-	-	-	-	0.055	-	-
water increase, max., grams per sq. in.....	-	-	-	-	-	0.025	-
Water-vapor permeability; grams per sq. meter per 24 hours (perms.)							
Max.....	4	6	-	-	-	-	2
Min.....	-	-	-	3<UT>	-	-	-
Bursting strength; min., points.....	-	-	-	-	-	70	-
Tearing resistance; min., grams.....	-	-	-	-	-	150	-

[1] Strength or style 6 shall be 15 pounds. Strength of styles 1, 2, 3, 4, 5, and 7 shall be 20 pounds, except that when specified (see 6.2) the strength shall be 35 pounds.

UU-B-790a

3.6.2 Grade B, Moderate water-vapor resistant. Grade B paper shall have the dry tensile strength, water-resistance, and water-vapor permeability properties shown in table II.

3.6.3 Grade C, Water resistant. Grade C paper shall have the dry tensile strength and water-resistance properties shown in table II.

3.6.4 Grade D, Water-vapor permeable. Grade D paper shall have the dry tensile strength, water-resistance, and water-vapor permeability properties shown in table II.

3.6.5 Style 1a, Uncreped, unreinforced. Style 1a paper shall be uncreped and shall not be reinforced.

3.6.6 Style 1b, Uncreped, unreinforced, red rosin sized. Style 1b paper shall be uncreped, not reinforced, and shall be coated with red rosin sizing.

3.6.7 Style 2, Uncreped, unreinforced, saturated. Style 2 paper shall be uncreped, not reinforced, and shall be saturated or infused with asphalt on both sides. Ground wood pulp may be included in the paper.

3.6.8 Style 3, Creped one direction, unreinforced. Style 3 paper shall be creped in one direction, not reinforced, and shall have a minimum elongation (stretch) of 15 percent.

3.6.9 Style 4, Uncreped, reinforced. Style 4 paper shall be uncreped and reinforced.

3.6.10 Style 5, Creped one direction, reinforced. Style 5 paper shall be creped in one direction, reinforced, and shall have a minimum elongation of 10 percent.

3.6.11 Style 6, Creped two directions, unreinforced. Style 6 paper shall be creped in two directions or creped in one direction and pleated or corrugated in the other direction. It shall not be reinforced and shall have a minimum elongation of 15 percent.

3.6.12 Style 7, Creped two directions, reinforced. Style 7 paper shall be creped in two directions or creped in one direction and pleated or corrugated in the other direction. It shall be reinforced and shall have a minimum elongation of 15 percent.

3.7 Type II, Concrete curing paper. Type II paper shall have reinforcement imbedded in the combining agent at intervals of not more than 1-1/4 inches in both directions.

3.7.1 Grade E, Moisture retentive. Grade E paper shall have the wet tensile strength and water-retention properties shown in table II.

3.7.1.1 Style 8, Regular color, reinforced. Style 8 paper shall be reinforced and shall have a natural color.

3.7.1.2 Style 9, White reinforced. Style 9 paper shall be reinforced and shall be white one side.

3.8 Type III, Fire resistant. When tested as specified in 4.5.2.4, type III paper shall not char more than 5-1/2 inches for any one sample and not more than an average of 4-1/2 inches for all samples.

3.8.1 Grade F, Water repellent. Grade F paper shall have the bursting strength, tearing resistance, and water-increase properties shown in table II.

3.8.2 Style 10, 56-pound paper. Style 10 paper shall weigh 56 pounds per 1,000 square feet, plus or minus 5 percent.

3.9 Type IV, Insulation tape paper. Type IV paper shall have cord or strand reinforcement imbedded in the combining agent of the lamination at intervals of not less than 1/2 inch in both directions.

3.9.1 Grade G, High tensile strength, water resistant. Grade G paper shall have the dry tensile strength, water resistance and water-vapor permeability properties shown in table II.

3.9.2 Style 11, Reinforced. Style 11 paper shall be uncreped and reinforced.

3.10 Workmanship. The paper shall be uniformly constructed and free from holes, tears, creases, cuts, or other imperfections which might impair its usefulness.

UU-B-790a

4. QUALITY ASSURANCE PROVISIONS

4.1 Responsibility for inspection. Unless otherwise specified in the contract or purchase order, the supplier is responsible for the performance of all inspection requirements as specified herein. Except as otherwise specified in the contract or order, the supplier may use his own or any other facilities suitable for the performance of the inspection requirements specified herein, unless disapproved by the Government. The Government reserves the right to perform any of the inspections set forth in the specification where such inspections are deemed necessary to assure that supplies and services conform to prescribed requirements.

4.2 Classification of inspection. Inspection shall be classified as follows:

- (a) Initial production inspection (see 4.3).
- (b) Quality conformance inspection (see 4.4).
- (c) Inspection comparison (see 4.6).
- (d) Inspection of preparation for delivery (see 4.7).

4.3 Initial production inspection. An initial production roll of building paper will be selected at random by the Government from the first twenty rolls of building paper being produced from production tooling and will be examined as specified in 4.5.1 and tested as specified in 4.5.2 through 4.5.2.6 to determine conformance to the requirements of this specification. The inspection will be performed by the Government at a site selected by the Government. Acceptance of the the initial production building paper shall not exclude the remaining rolls of building paper from the quality conformance inspection and acceptance provisions specified in section 4.

4.3.1 Inspection failure. Failure of the initial production building paper to meet any requirement specified herein during and as a result of the examination and tests specified in 4.3 shall be cause for rejection of the initial production building paper and shall be cause for refusal by the Government to continue acceptance of production building paper until evidence has been provided by the supplier that the corrective action has been taken to eliminate the deficiencies. Correction of such deficiencies shall be accomplished by the supplier at no cost to the Government on rolls of building paper previously accepted and produced under the contract. Any deficiencies found as a result of the initial production testing will be considered prima facie evidence that all rolls of building paper accepted prior to the completion of initial production testing are

similarly deficient unless evidence to the contrary is furnished by the supplier and such evidence is acceptable to the contracting officer.

4.4 Quality conformance inspection.

4.4.1 Sampling.

4.4.1.1 For examination. Sampling for examination shall be in accordance with MIL-STD-105.

4.4.1.2 For tests. Sampling for tests shall be in accordance with MIL-STD-105, inspection level S-2.

4.4.1.3 Lot. For the purpose of inspection, a lot shall consist of all the rolls of paper of the same type, grade, and style offered for delivery at one time.

4.4.2 Examination. Samples selected in accordance with 4.4.1.1 shall be examined as specified in 4.5.1. AQL shall be 4.0 percent defective.

4.4.3 Test. Samples selected in accordance with 4.4.1.2 shall be tested as specified in 4.5.2 through 4.5.2.6. AQL shall be 4.0 percent defective.

4.5 Inspection procedure.

4.5.1 Examination. The paper shall be examined for the following defects:

101. Material not as specified.
102. Construction not as specified.
103. Treatment omitted.
104. Reinforcement omitted.
105. Rolls not one piece.
106. Splice not as specified.
107. Rolls not of the size specified.
108. Creping omitted or not as specified.
109. Workmanship not as specified.

4.5.2 Tests.

4.5.2.1 Test specimens. Test specimens shall be of the size designated by the applicable test or as otherwise specified herein.

UU-B-790a

The specimens shall be cut from the interior of the sample roll so that no specimen edge is nearer than 3 inches to the original sample edge. A minimum of ten specimens, five in each direction of the paper, shall be cut from each sample for fire-resistance tests. Five specimens, each 5 inches square, shall be cut from each sample for water-repellency tests. One specimen, 6 inches by 1 inch in the machine direction of the paper shall be cut from each sample for the pliability test.

4.5.2.2 Grade requirement. The grade requirement tests shall be made in accordance with the applicable test methods specified in UU-P-31 as follows:

<u>Test</u>	<u>Method number</u>
Basis weight (style 10 only).....	110
Bursting strength.....	112
Fiber identification and quantitative determination of the paper content.....	300
Tearing resistance.....	170
Tensile breaking strength (dry) and elongation [1].....	171
Tensile breaking strength, wet [1].....	172
Water resistance.....	181
Water-vapor permeability [2].....	182

[1] Test specimens shall be 2 inches in width and the test values shall be divided by 2 to obtain the values per inch width. Immersion time is 24 hours in water at 73 deg. plus or minus 3.5 deg. F. for the wet tensile test.

[2] At 50 percent plus or minus 2 percent relative humidity and 73 deg. plus or minus 3.5 deg. F.

Nonconformance to grade requirements of table II shall constitute failure of this test.

4.5.2.3 Water loss. The paper shall be tested in accordance with ASTM C156. An average loss in grams per square centimeter exceeding the value shown in table II shall constitute failure of this test.

4.5.2.4 Fire resistance (type III only). The paper shall be tested in accordance with ASTM D777. Evidence of char in excess of an average length of 4-1/2 inches or a maximum of 5-1/2 inches for any one specimen shall constitute failure of this test.

4.5.2.5 Water increase. The paper shall be tested in accordance with the following procedures.

4.5.2.5.1 Apparatus. The test apparatus shall consist of a metal ring, 4 inches inside diameter, 3 inches high, and 1/4 inch thick. The bottom edge of the ring shall be smoothly machined. The ring shall be used with a yoke, consisting of a plate, uprights, and a crossbar. The plate shall be not less than 6 by 6 inches and 3/16 inch thick. It shall have two threaded upright rods 4 inches high. The crossbar shall be 7 inches by 1 inch, notched at one end, and drilled through the other end to permit mounting over the ring on the upright rods. Wing nuts shall be threaded on the rods for tightening the crossbar on the ring top. Rubber mats or soft felts, about 5-1/2 inches square, shall be provided (see fig. 1).

4.5.2.5.2 Reagent. Water of reasonable purity, such as ordinary drinking water, shall be used in the test. The water shall be maintained at a temperature of from 68 deg. to 71 deg. F.

4.5.2.5.3 Test conditions. The specimens shall be conditioned by method 102 of UU-P-31 for a period of not less than 48 hours, and the tests shall be conducted under the atmospheric conditions specified therein.

4.5.2.5.4 Procedure. Weigh the specimen to the nearest 0.001 gram and record as the original weight. Place the specimen on top of the mat and fit the sandwich thus formed between the uprights of the yoke so that the mat is in contact with the yoke plate. If only one side of the specimen has been treated, the untreated side shall contact the mat. Place the ring upon the sample and securely fasten the yoke crossbar over the ring. The ring must be clamped tightly upon the specimen to prevent leakage around the bottom of the ring where it contacts the specimen. Pour the water into the ring to a depth of not less than 3/16 inch, taking care to wet the entire specimen surface exposed inside the ring simultaneously. Start a stopwatch at the time of pouring. Allow the water to remain on the specimen until 15 or 20 seconds before a period of 5 minutes has elapsed, at which time the water should be quickly poured out of the ring. Do not permit the water to touch any untested portion of the specimen. Quickly loosen the crossbar, lift the ring carefully and, at the end of the 5-minute period, mop the surface of the specimen with a large soft rag sufficiently

UU-B-790a

to remove all excess water. Fold the specimen with the tested portion inside and reweigh to the nearest 0.001 gram. The actual tested area of the specimen shall be determined to the closest 0.001 square inch.

4.5.2.5.5 Calculation. The water absorbed in grams per square inch shall be determined by the formula:

$$A = \frac{W}{S}$$

Where:

A is the absorption in grams per square inch.
 W is the weight gained during the test in grams, and
 S is the tested area of the specimen in square inches.

The results of the tests on each of the five specimens shall be averaged. An average absorption in grams per square inch exceeding the value shown in table II shall constitute failure of this test.

4.5.2.6 Pliability. The specimen shall be exposed to an ambient temperature of 32 deg. F. for 1 hour prior to the test. Bend the specimen over a 1/16-inch mandrel through an arc of 180 degrees at a uniform rate in 2 seconds. Any visible evidence of cracking of the paper shall constitute failure of this test.

4.6 Inspection comparison. The Government may select rolls of building paper at any time during the contract production period and subject these rolls to the examination specified in 4.5.1 and the tests specified in 4.5.2 through 4.5.2.6 to determine that the quality of the selected rolls for building paper is equal to the quality standards established during initial production testing. The inspection will be performed by the Government at a site selected by the Government. Rolls of building paper will be selected at random from those which have been accepted by the Government and will not include the previously inspected initial production building paper.

4.6.1 Inspection failure. Failure of any rolls when inspected as specified in 4.7 may be considered cause for refusal by the Government to continue acceptance of rolls until objective evidence furnished by the supplier reveals that corrective action has been taken to eliminate the condition which caused the rejection.

4.7 Inspection of preparation for delivery.

4.7.1 Quality conformance inspection of pack.

4.7.1.1 Unit of product. For the purpose of inspection, a completed pack prepared for shipment shall be considered a unit of product.

4.7.1.2 Sampling. Sampling for examination shall be in accordance with MIL-STD-105, inspection level S-2.

4.7.1.3 Examination. Samples selected in conformance with 4.7.1.2 shall be examined for the following defects. AQL shall be 2.5 percent defective.

- 110. Materials, methods and containers not as specified.
Each incorrect material, method or container shall be considered one defect.
- 111. Waterproof wrap not properly sealed.
- 112. Boxes not as specified for level A or B.
- 113. Strapping not as specified for level A.
- 114. Strapping not properly applied for level A or B.
- 115. Marking illegible, incomplete or incorrect.

5. PREPARATION FOR DELIVERY

5.1 Packaging. Packaging shall be level A or C, as specified, (see 6.2).

5.1.1 Level A. Each roll of building paper shall be wrapped with barrier material conforming to PPP-B-1055, class E-2, and all joints, seams and laps of the wrap sealed with tape conforming to PPP-T-60, class 1.

5.1.2 Level C. The rolls of building paper shall be packaged in a manner to afford protection against damage from the supplier to the initial destination.

5.2 Packing. Packing shall be level A, B, or C, as specified (see 6.2).

5.2.1 Level A. The rolls of building paper of like size and description, packaged as specified in 5.1 shall be packed in close-fitting cleated-plywood boxes conforming to PPP-B-601, overseas

UU-B-790a

type, style optional. The boxes shall be closed and strapped in accordance with the appendix to the box specification. Strapping shall be zinc coated. Gross weight of boxes exceeding 250 pounds shall be modified by the installation of skids in accordance with the box specification.

5.2.2 Level B. The rolls of building paper shall be packed as specified in 5.2.1, except the boxes shall be domestic type and the strapping need not be zinc coated.

5.2.3 Level C. The rolls of building paper shall be packed to assure carrier acceptance and safe delivery to destination at lowest rates in compliance with Uniform Freight Classification Rules or National Motor Freight Classification Rules.

5.3 Marking.

5.3.1 Civil agencies. In addition to any special marking required, interior and exterior shipping containers shall be marked in accordance with Fed. Std. No. 123.

5.3.2 Military agencies. In addition to any special marking required, interior and exterior shipping containers shall be marked in accordance with MIL-STD-129.

6. NOTES

6.1 Intended use.

6.1.1 Type I. The paper is intended for use in waterproofing, and as a vapor barrier, flashing, or similar protection.

6.1.2 Type II. The paper is intended for use as a covering over fresh concrete to prevent loss of moisture and induce a more thorough hydration.

6.1.3 Type III. The paper is intended for use as a covering for thermal insulation for cold piping or tubing prior to lagging.

6.1.4 Type IV. The paper is intended for use in taping insulation joints to limit movement between insulation units due to thermal shrinkage, and reduce splitting failures in built-up roofs, in conformance to methods researched by the National Bureau of Standards and described in NBS Monograph 89.

6.2 Ordering data. Purchasers should select the preferred options permitted herein and include the following information in procurement documents:

- (a) Title, number, and date of this specification.
- (b) Type, grade, and style required (see 1.2.1).
- (c) When initial production paper is required, and the number of rolls (see 3.2).
- (d) Width and length, or area of roll required (see 3.5).
- (e) When 35-lb. strength type I paper is required (see table II).
- (f) Selection of applicable levels of packaging and packing required (see 5.1 and 5.2).

6.3 Type II, grade E paper of this specification is similar to the paper specified in ASTM C171.

6.4 Classification changes. Style 1 changed to Style 1a and Style 1b to include red rosin sized paper. Type IV added to include insulation tape paper.

MILITARY CUSTODIANS:

Army - ME
Navy - YD
Air Force - 84

Preparing activity:

Army - ME

User activity:

Army - CE

Review activities:

Army - MD
Navy - YD
Air Force - 84, 85

CIVIL AGENCIES INTEREST:

GSA
VA

UU-B-790a

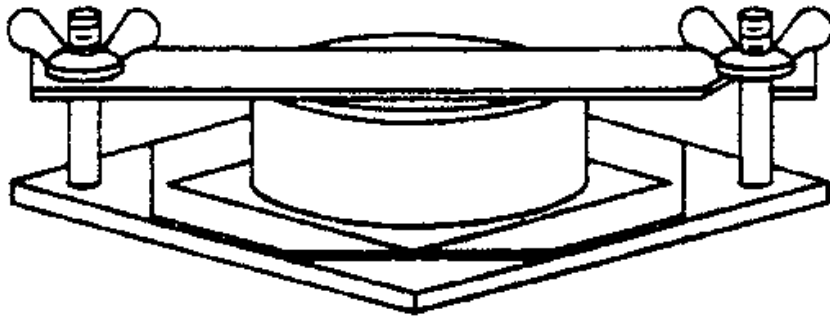
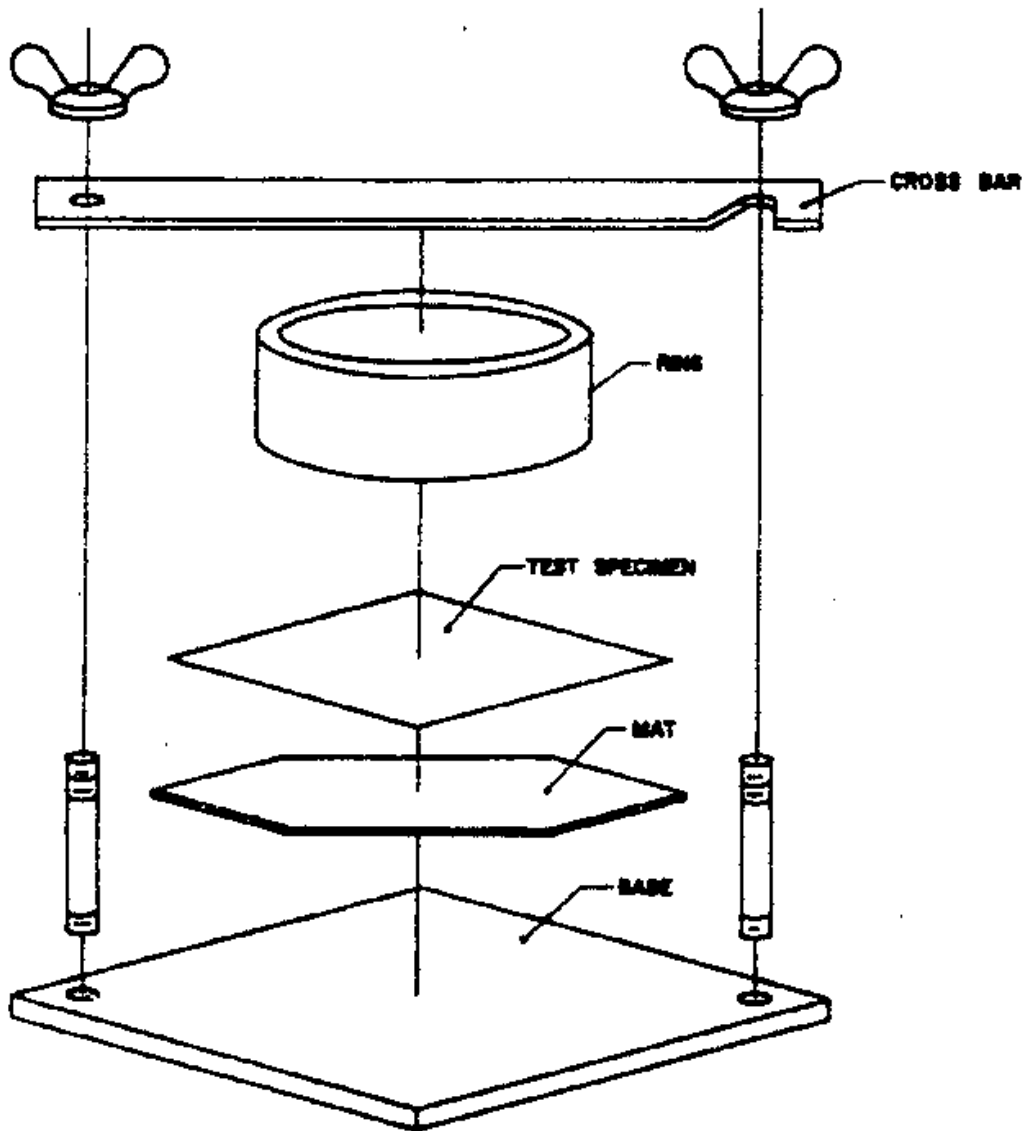

Figure 1.— WATER REPELLENCY TEST APPARATUS



ASSEMBLY BREAK DOWN

Orders for this publication are to be placed with General Services Administraton, acting as an agent for the Superintendent of Documents. See section 2 of this specification to obtain extra copies and other documents referenced herein. Price 10 cents each.

UU-B-790a
INTERIM AMENDMENT-1
September 22, 1976

INTERIM AMENDMENT

TO

FEDERAL SPECIFICATION

BUILDING PAPER, VEGETABLE FIBER:
(KRAFT, WATERPROOFED, WATER REPELLENT
AND FIRE RESISTANT)

This interim amendment was developed by the General Services Administration, Federal Supply Service, Washington, DC 20406, based upon currently available technical information. It is recommended that Federal agencies use it in procurement and forward recommendations for changes to the preparing activity at the address shown above.

The General Services Administration has authorized the use of this interim amendment as a valid exception to Federal Specification UU-B-790a dated February 5, 1968.

PAGE 9

Delete paragraph 4.4.1.3 entirely.

PAGE 13

Add paragraph 4.8 as follows:

4.8 CERTIFICATION: A certificate of compliance shall be acceptable as proof that the product being offered meets the requirements of Table II, provided the contractor furnishes actual test results, acceptable to the Government, indicating that tests have been performed to substantiate the certification. The certification shall state that the tests described in paragraphs 4.5.2.2, 4.5.2.3, 4.5.2.4, and 4.5.2.5, have been performed on products manufactured from the same material and manufacturing process of the items being offered and that any proposed changes in material or process will be promptly reported to the Government. The Government reserves the right to require additional testing and certification by the contractor when such changes are made or when otherwise deemed necessary.

FSC 5640

UU-B-790a

MILITARY CUSTODIANS:

Army - ME
Navy - YD
Air Force - 84

Review activities:

Army - MD
Navy - YD
Air Force - 84, 85

User Activity:

Army - CE

Civil Agencies Interest:

GSA
VA

Preparing Activity:

GSA-FSS

NOTICE OF
REINSTATEMENT

INCH-POUND

UU-B-790A
NOTICE 2
24 April 1992

SUPERSEDING
NOTICE 1
30 April 1991

FEDERAL SPECIFICATION

BUILDING PAPER, VEGETABLE FIBER:
(KRAFT, WATERPROOFED, WATER REPELLENT
AND FIRE RESISTANT)

UU-B-790A, dated 5 February 1968, is hereby reinstated and may be used for acquisition. The Naval Facilities Engineering Command (YD) assumes preparing activity responsibility in lieu of the General Services Administration, Federal Supply Service.

(Copies of the referenced federal and military specifications, standards, and handbooks are available from the Standardization Documents Order Desk, Bldg 4D, 700 Robbins Avenue, Philadelphia, PA 19111-5094.)

MILITARY INTERESTS:

CIVIL AGENCY COORDINATED ACTIVITIES:

Custodians:

GSA - FSS 7FXE
VA - OSS

Army - ME
Navy - YD
Air Force - 99

Preparing Activity

User Activity

Navy - YD

Army - CE

(Project 5640-0553)

FSC 5640

DISTRIBUTION STATEMENT A. Approved for public release; distribution is unlimited.